

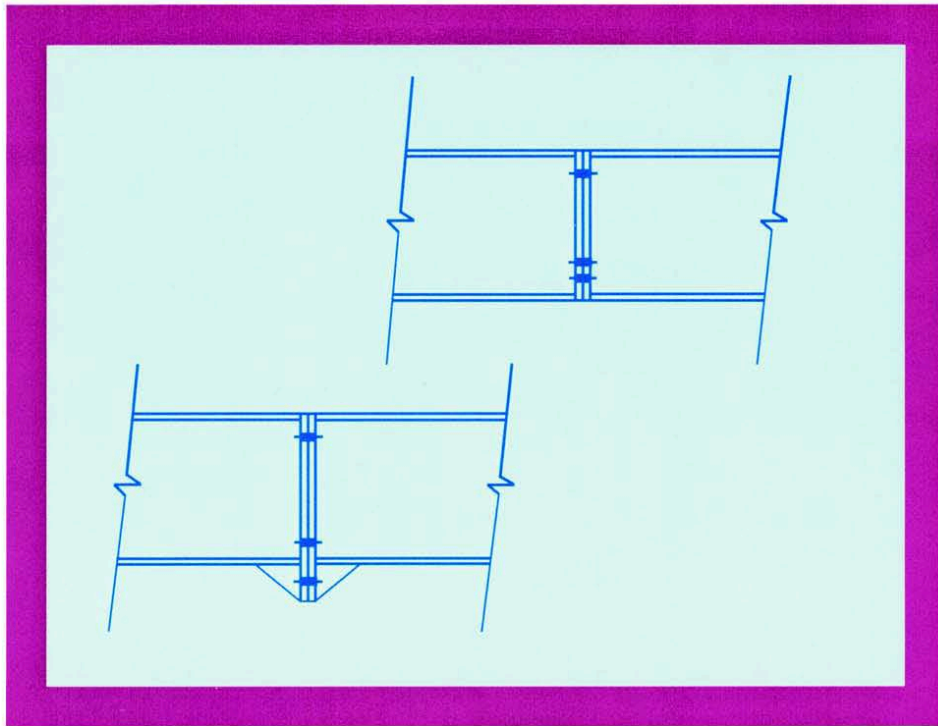

Steel Design Guide Series

16

Flush and Extended Multiple-Row Moment End-Plate Connections





Steel Design Guide Series

16

***Flush and Extended Multiple-Row
Moment End-Plate Connections***

Thomas M. Murray, P.E., Ph.D.

Montague Betts Professor of Structural Steel Design
Charles E. Via Department of Civil Engineering
Virginia Polytechnic Institute and State University
Blacksburg, Virginia

W. Lee Shoemaker, P.E., Ph.D.

Director of Research & Engineering
Metal Building Manufacturers Association
Cleveland, Ohio

Copyright © 2002

by

American Institute of Steel Construction, Inc.

*All rights reserved. This book or any part thereof
must not be reproduced in any form without the
written permission of the publisher.*

The information presented in this publication has been prepared in accordance with recognized engineering principles and is for general information only. While it is believed to be accurate, this information should not be used or relied upon for any specific application without competent professional examination and verification of its accuracy, suitability, and applicability by a licensed professional engineer, designer, or architect. The publication of the material contained herein is not intended as a representation or warranty on the part of the American Institute of Steel Construction or of any other person named herein, that this information is suitable for any general or particular use or of freedom from infringement of any patent or patents. Anyone making use of this information assumes all liability arising from such use.

Caution must be exercised when relying upon other specifications and codes developed by other bodies and incorporated by reference herein since such material may be modified or amended from time to time subsequent to the printing of this edition. The Institute bears no responsibility for such material other than to refer to it and incorporate it by reference at the time of the initial publication of this edition.

Printed in the United States of America

Second Printing: October 2003

Published by the American Institute of Steel Construction, Inc.
At One East Wacker Drive, Suite 3100, Chicago, IL 60601

The co-sponsorship of this publication by the Metal Building
Manufacturers Association is gratefully acknowledged.

ACKNOWLEDGMENTS

Design procedures in this Guide are primarily based on research conducted at the University of Oklahoma and at Virginia Polytechnic Institute. The research was sponsored by the Metal Building Manufacturers Association (MBMA), the American Institute of Steel Construction (AISC), and Star Building Systems. MBMA and AISC member companies provided test specimens. The work of former Oklahoma and Virginia Tech graduate students, Ramzi Srouji, David M. Hendrick, Scott J. Morrison, Mary Sue Abel, and Jeffrey T. Borgsmiller, made this Guide possible. Virginia Tech graduate students Emmett A. Sumner III and Timothy R. Mays contributed valuable work to update the yield line mechanisms used and with final checking of the design procedures. The assistance of Patrick Toney, Star Building Systems, in developing the final manuscript is gratefully appreciated and acknowledged.

TABLE OF CONTENTS

1. Uses and Classification of Moment End-Plate Connections	1	3.2.3 Four-Bolt Flush Stiffened Moment End-Plate Connection (Stiffener Between Bolt Rows).....	25
1.1 Introduction.....	1	3.2.4 Four-Bolt Flush Stiffened Moment End-Plate Connection (Stiffener Outside Bolt Rows).....	27
1.2 Background.....	3	4. Extended End-Plate Design	31
1.2.1 Design Procedures for Moment End-Plates with Fully Tightened Bolts.....	3	4.1 Design Equations, Limitations, and Definitions.....	31
1.2.2 Design Procedures for Moment End-Plates with Snug Tight Bolts.....	5	4.1.1 Design Equations.....	31
1.2.3 Finite Element Analysis of Moment End-Plates.....	5	4.1.2 Limitations.....	31
1.2.4 Performance of Moment End-Plate Connections for Seismic Loading.....	6	4.1.3 Definitions.....	31
2. Design Procedures	7	4.2 Design Examples.....	39
2.1 Introduction.....	7	4.2.1 Four-Bolt Extended Unstiffened Moment End-Plate Connection.....	39
2.2 Yield-Line Theory and Mechanics.....	7	4.2.2 Four-Bolt Extended Stiffened Moment End-Plate Connection.....	41
2.3 Bolt Force Predictions.....	7	4.2.3 Multiple Row 1/2 Extended Unstiffened Moment End-Plate Connection.....	43
2.4 Moment-Rotation Relationships.....	8	4.2.4 Multiple Row 1/3 Extended Unstiffened Moment End-Plate Connection.....	45
2.5 Design Procedures.....	9	4.2.5 Multiple Row 1/3 Extended Stiffened Moment End-Plate Connection.....	47
2.5.1 Design Procedure 1.....	10	5. Gable Frame Panel Zone Design	51
2.5.2 Design Procedure 2.....	11	5.1 Introduction.....	51
2.5.3 Additional Assumptions and Conditions.....	12	5.2 LRFD Rules and Example Calculations.....	52
2.6 Limit States Check List.....	13	5.2.1 LRFD Rules.....	52
3. Flush End-Plate Design	17	5.2.2 LRFD Example.....	52
3.1 Design Equations, Limitations, and Definitions.....	17	5.3 Allowable Stress Design Rules and Example Calculations.....	54
3.1.1 Design Equations.....	17	5.3.1 Allowable Stress Design Rules.....	54
3.1.2 Limitations.....	17	5.3.2 ASD Example Calculations.....	55
3.1.3 Definitions.....	17	REFERENCES	57
3.2 Design Examples.....	22	APPENDIX A: Nomenclature	61
3.2.1 Two-Bolt Flush Unstiffened Moment End-Plate Connection.....	22	APPENDIX B: Bolted End-Plate Connection Analysis Flowchart	63
3.2.2 Four-Bolt Flush Unstiffened Moment End-Plate Connection.....	23		

Chapter 1

USE AND CLASSIFICATION OF MOMENT END-PLATE CONNECTIONS

1.1 Introduction

The low-rise metal building industry has pioneered the use of moment end-plate connections in the United States. These bolted connections are used between rafters and columns and to connect two rafter segments in typical gable frames as shown in Figures 1-1 and 1-2. Hence, built-up shapes used in the metal building industry are exclusively used in the examples; however, the design procedures also apply to hot-rolled shapes of comparable dimensions to the tested parameter ranges (i.e. Tables 3-6 and 4-7).

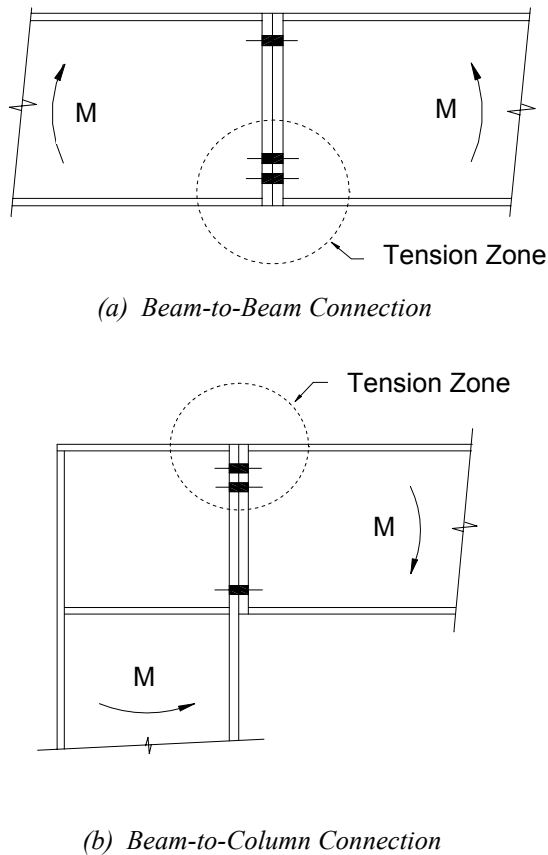
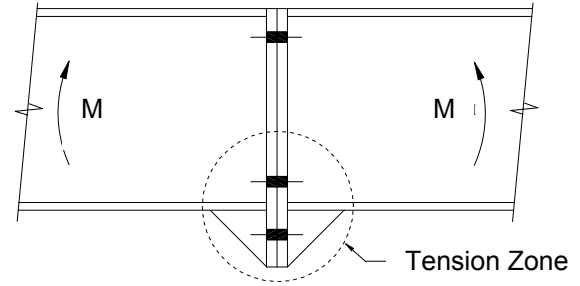
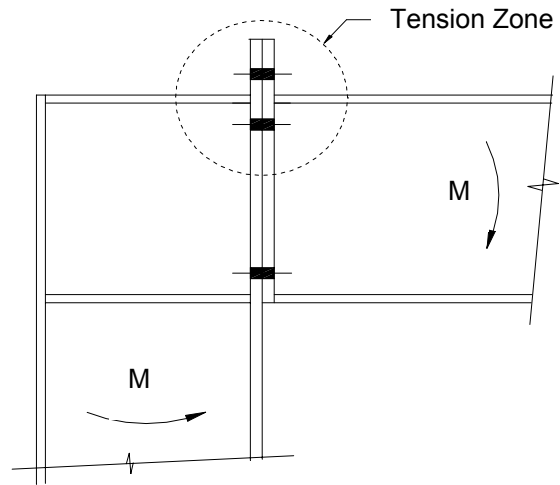

Figure 1-1 Typical uses of end-plate moment connections (flush).

Rigid frame or continuous frame construction, designated Type FR in the American Institute of Steel Construction (AISC) Load and Resistance Factor Design (LRFD) Specification or Type 1 in the AISC Allowable Stress Design (ASD) Specification, is usually assumed for



(a) Beam-to-Beam Connection



(b) Beam-to-Column Connection

Figure 1-2 Typical uses of end-plate moment connections (extended).

the design of the frames. The moment end-plate connection is one of three fully restrained moment connections, as defined in the AISC *Manual of Steel Construction, Load & Resistance Factor Design, 2nd Ed.* (1994), that can be used for FR (or Type 1) beam-to-column connections.

A typical end-plate moment connection is composed of a steel plate welded to the end of a beam section with attachment to an adjacent member using rows of high-strength bolts. End-plate moment connections are classified as either flush or extended, with or without stiffeners, and further classified depending on the number of bolts at the tension flange. Depending on the direction of the moment and whether the connection will see a moment reversal, the bolted end-plate may be designed to carry

tension at the top or bottom, or both. This could result in a design with a combination of configurations such as a flush end-plate at the compression side and an extended end-plate at the tension side.

A flush connection is detailed such that the end-plate does not appreciably extend beyond the beam flanges with all bolts located between the beam flanges. An extended end-plate is one that extends beyond the tension flange a sufficient distance to allow the location of bolts other than between the beam flanges. Flush end-plate connections are typically used in frames subject to light lateral loads or near inflection points of gable frames. Extended end-plates are typically used for beam-to-column moment connections. However, flush end-plates are sometimes used for beam-to-column moment connections when a plate extension would interfere with other members or the roof deck.

Four flush and five extended end-plate connections are within the scope of this Guide. The four types of flush

end-plate configurations are shown in Figure 1-3. Figures 1-3a and 1-3b show unstiffened flush end-plate connections with two and four bolts near the tension flange. Figures 1-3c and 1-3d show stiffened flush end-plate connections with four bolts near the tension flange. In Figure 1-3c a web stiffener plate is located on both sides of the web between the two tension bolt rows, while in Figure 1-3d the web stiffener plates are located inside the two tension bolt rows. For both connections, the stiffener plates are welded to both the end-plate and the beam web.

The five extended end-plate configurations are shown in Figure 1-4. Figure 1-4a shows an extended, unstiffened end-plate connection with four bolts at the tension flange and Figure 1-4b shows the same connection with an end-plate to beam flange stiffener. The unstiffened connection shown in Figure 1-4a is probably the most commonly used end-plate configuration. Three multiple row extended end-plate configurations are shown in Figures 1-4c, 1-4d and 1-4e. These configurations have one row of

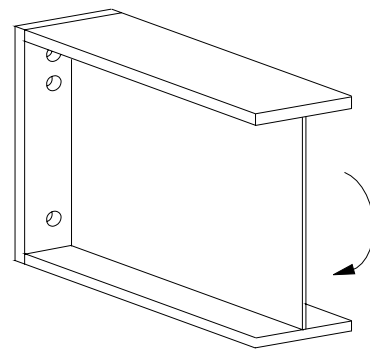
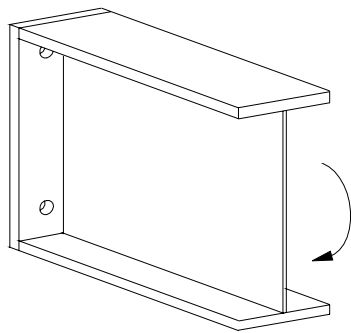

(b) Four-Bolt Unstiffened

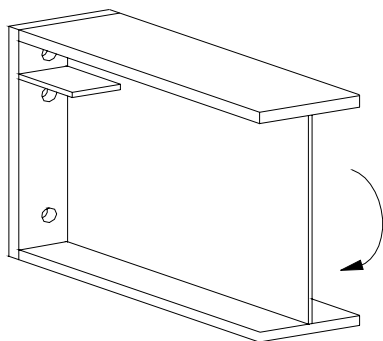

(c) Four-Bolt Stiffened with Web Gusset Plate Between the Tension Bolts

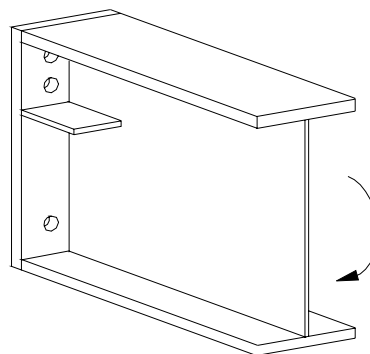

(d) Four-Bolt Stiffened with Web Gusset Plate Between the Tension Bolts

Figure 1-3 Flush end-plate connections.

bolts outside the tension flange and either two or three rows of bolts inside the tension flange. They are identified with the notation 1/n, where “n” is the number of bolt rows inside the tension flange. The connection shown in Figure 1-4c is designated as the unstiffened 1/2 configuration, while the connections shown in Figures 1-4d and 1-4e are designated as unstiffened and stiffened 1/3 configurations, respectively.

The primary purpose of this Guide is to provide a convenient source of design procedures for the nine connections shown in Figures 1-3 and 1-4. In addition, design considerations for the “knee area” of rigid frames are discussed.

The end-plate connection design procedures presented here use yield-line techniques for the determination of end-plate thickness and include the prediction of tension bolt forces. The bolt force equations were developed because prying forces are important and must be considered in bolt force calculations. Moment-rotation considerations are also included in the design procedures. Chapter 2 contains the general design procedures. Design procedures for flush connections are found in Chapter 3 and for extended connections in Chapter 4. Knee area design criteria are given in Chapter 5. The analysis of bolted end-plate connections is covered in Appendix B. Both Allowable Stress Design (ASD) and Load and Resistance Factor Design (LRFD) procedures are discussed and illustrated throughout the Guide.

1.2 Background

1.2.1 Design Procedures for Moment End-Plates With Fully Tensioned Bolts

The end-plate moment connection saw its first application in the 1960’s, stemming from research in the 1950’s. The connection was not a new concept but more of an evolution of the much-used split tee connection (Disque 1962). The early designs usually resulted in thick end-plates and large bolt diameters due mainly to simplified design assumptions and analyses of the connection. The connection slowly gained acceptance and was included in the *AISC Manual of Steel Construction, 7th Ed.* (1970) due in large part to the efforts of Douty and McGuire (1965). Their methods used assumptions concerning bolt forces due to prying action and simple statics resulting from earlier tee-stub analysis. As discussed by Griffiths (1984), this first attempt to standardize the design resulted in a very conservative connection. It did spur further interest as seen by various studies in the early 1970’s. Kato and McGuire (1973) and Nair, et al. (1974) continued the tee-stub concept to account for prying action. As before, the procedures continued to produce a design with thick plates and large bolt diameters. Based on this research and that of Agerskov (1976, 1977), Granstrom (1980) continued with a simple design of tee-hangers. His resulting design produced thinner plates and smaller diameter bolts than before, but he did not consider the effects of prying action.

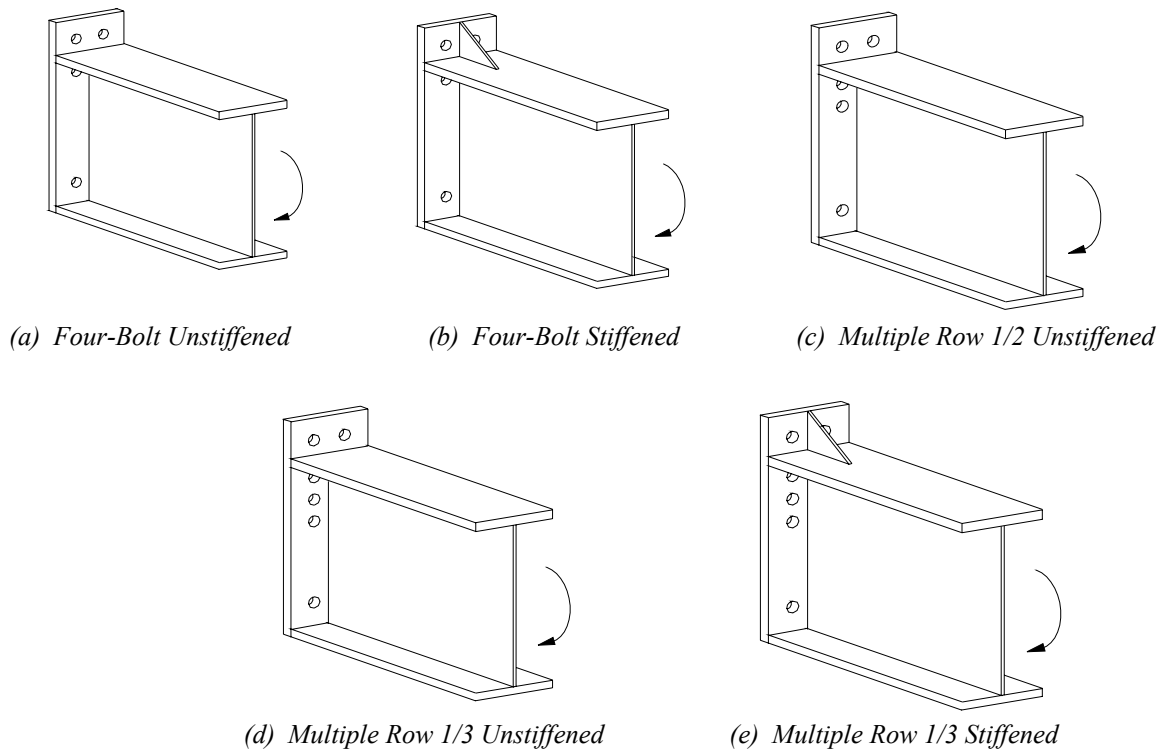

Figure 1-4 Extended end-plate connections.

Packer and Morris (1977) were among the first to use yield-line analysis. Using the tee-stub model for the end-plate, they developed a yield line analysis of the column flanges. Mann and Morris (1979) extended these initial efforts in the use of yield line analysis. From review of previous research, they surmised that the end-plate must exhibit plastic deformation and the formation of yield lines when near its capacity. Their proposed design procedures determined plate thickness and bolt diameter as well as adequacy checks for the supporting column.

Krishnamurthy (1978) broke from the traditional analysis and derived empirical relationships based on statistical analysis of finite element results. Formulas derived for end-plate thickness provided thinner plates than previously obtained. He explained the prying force as a pressure bulb formed under the bolt head due to the tensioning of the bolts. The location of the pressure bulb varied, depending on the level of the flange force in the beam. As the force increases, the pressure bulb shifts towards the edge of the plate. The design procedures in the current editions of the *AISC Manual of Steel Construction* are in part based on his basic work.

Kennedy, et al. (1981) refined the tee-stub analysis to include the prediction of prying forces utilizing yield line theory and the formation of plastic hinges. They categorized the tee-stub flange behavior on three levels. First, at low loads, there is the absence of any hinge formation in the flange plate and the plate is said to be “thick,” with no prying action present. Second, upon the formation of a hinge caused by yielding of the flange at the tee-stem, the plate is said to be “intermediate.” Some prying action during the intermediate case is realized and adds to the bolt forces. The third stage, “thin,” is determined when the second plastic hinge forms at the bolt line. At this load level, the prying action is considered to be at its maximum.

Srouji, et al. (1983a) used yield-line analysis and the Kennedy method of bolt force predictions in the first of many studies conducted by Professor T. M. Murray at the University of Oklahoma and Virginia Polytechnic Institute aimed at moment end-plate design unification. They presented yield-line design methodology for a two-bolt flush, unstiffened end-plate configuration (Figure 1-3a). A later report by Srouji, et al. (1983b) extended the work to other configurations including the four-bolt flush, unstiffened connection (Figure 1-3b). Bolt force predictions including prying action were produced for the two-bolt and four-bolt flush, unstiffened configurations. An experimental investigation was conducted to verify the end-plate and bolt force predictions. It was concluded that yield-line analysis and a modified Kennedy method are accurate methods for predicting end-plate strength and bolt forces.

Hendrick, et al. (1984) continued Srouji's work by analyzing and testing two different four-bolt flush stiffened end-plate configurations: those with the stiffener

between the tension bolt rows (Figure 1-3c), and those with the stiffener inside the tension bolt rows (Figure 1-3d). Analysis included the use of yield-line theory for end-plate strength predictions and the modified Kennedy approach for bolt force predictions. Analytical predictions for end-plate strength using yield-line theory and bolt forces using the modified Kennedy approach correlated well with data. However, an improvement in the method for determining the internal work for the yield line analysis was presented by Hendrick, et al. (1985) for the connection with the stiffener outside the tension bolt rows.

It was also determined by Hendrick, et al. (1985) that the connections behaved as a Type 1 or FR connection up to a certain percentage of the failure moment of the end-plate at which point the moment-rotation curve softens. An analysis of the moment-rotation curves for the beam specimens tested indicated that a conservative value of 80% of the failure moment was a reasonable limit to ensure Type 1 or FR behavior.

Four-bolt extended stiffened (Figure 1-4b) and multiple row extended unstiffened 1/3 (Figure 1-4d) configurations were tested and analyzed by Morrison, et al. (1985, 1986). Analysis procedures included the use of yield-line theory and modified Kennedy bolt force predictions. Modifications to the Kennedy method were necessary for determining the distribution of the applied flange force between the outer and inner bolts in the extended end-plate configurations. Morrison's modification factors came directly from the experimental results of six tests of four-bolt extended stiffened connections (Figure 1-4b) and six tests of multiple row extended unstiffened 1/3 connections (Figure 1-4d). It was concluded from these tests that the outer bolts do not exhibit prying action, and therefore carry the majority of the applied flange force. It was additionally concluded that the four-bolt extended stiffened and multiple row extended unstiffened 1/3 configurations contain adequate stiffness to be classified as Type 1 or FR connections.

Abel and Murray (1992b) added a final configuration to the unification of moment end-plate design: the four-bolt extended unstiffened configuration (Figure 1-4a). Analysis was conducted using the same yield-line analysis and modified Kennedy method. Four full-scale tests were conducted to verify the predictions. It was concluded that the outer and inner rows of bolts each carry half of the applied flange force, however, when the bolt force prediction controls in the analysis, no prying action exists in the outer bolts. As with the other configurations, the four-bolt extended unstiffened moment end-plate connection contains adequate moment-rotation stiffness to be classified as a Type 1 or FR connection.

Proprietary testing was carried out on the multiple row extended unstiffened 1/2 configuration of Figure 1-4c and the multiple row extended stiffened 1/3 configuration of Figure 1-4e as reported in Abel and Murray (1992a) and SEI (1984). The inclusion of these configurations in this

Guide is with the permission of the test sponsors as noted in the Acknowledgments. Also, additional confirmatory tests were conducted on the multiple row extended unstiffened 1/2 configuration of Figure 1-4c by Sumner and Murray (2001).

An historic overview of the advancement and the development of end-plate moment connection design is presented in greater detail by Murray (1988). It should be noted that as the referenced research reports of the various connections studied over the years were being assimilated into this Guide, some updates were incorporated. This includes some new governing yield-line mechanisms and the LRFD approach with the proper resistance factors. Therefore, one should use the previous reports with care and preferably, defer to this Guide as the correct approach to designing the bolted end-plate connections.

1.2.2 Design Procedures for Moment End-Plates with Snug Tight Bolts

Until just recently, all high-strength bolts in tension, including end-plate connections, had to be pretensioned to approximately 70% of the bolt tensile strength. Considerable savings would result during erection if the requirement for bolt tensioning were relaxed for some applications. Fleischman, et al. (1991) studied the behavior of snug-tightened bolts in large capacity moment end-plate connections and showed that less than full tightening did not affect the strength of the connection.

Kline, et al. (1989), as also reported in Murray, et al. (1992), subjected a number of end-plate configurations to cyclic loading. In their investigation, wind loads were considered to be the dominant contributor to lifetime loading on a building. A test loading sequence was established based on statistics of wind speed in the United States. Since it is known that the wind loading distribution on low-rise buildings is site dependent, the test loading was intended to be representative of the more severe wind loading locations. The experimental part of the study included tests of eleven full-scale end-plate connections representing five different configurations, those shown in Figures 1-3a, 1-3b, 1-4a, 1-4b, and 1-4d. All bolts used were A325 and they were snug-tightened prior to testing. A snug tight condition is defined by the Research Council on Structural Connections (2000) as “the tightness that exists when all plies in a joint are in firm contact. This may be attained by a few impacts of an impact wrench or the full effort of a man using an ordinary spud wrench.” The study by Kline, et al. (1989) observed that the pretension force measured in the snug-tightened bolts is directly proportional to the bolt diameter (d_b). Based on this data, a recommendation for the assumed pretension force in snug-tightened bolts to be used in the design procedure is:

$d_b \leq 5/8$ in., use 75% of specified AISC full pretension
 $d_b = 3/4$ in., use 50% of specified AISC full pretension

$d_b = 7/8$ in., use 37.5% of specified AISC full pretension
 $d_b \geq 1$ in., use 25% of specified AISC full pretension

Ten of the specimens were subjected to over 8000 cycles of loading which represent the expected loading for a fifty-year building life. One connection was subjected to 80,000 cycles to further verify the effect of cyclic loading on the connection. Although bolt forces decreased with increasing number of cycles, all of the connections survived the cyclic loading without bolt, end-plate, or weld failure.

On completion of the cyclic loading, each connection was loaded to failure. Ultimate moment strengths were calculated and compared to the test results. Yield-line analysis was used to determine end-plate strength and the modified Kennedy method was used to predict the connection strength based on bolt forces including prying forces, except for the four-bolt, extended, unstiffened connection shown in Figure 1-4a. The design method in the AISC 9th Ed. ASD Manual (1989) was used for this connection. This method does not include prying forces in the design of the bolts. Good correlation between applied and predicted ultimate moments was obtained for all connections except the four bolt, extended, unstiffened configuration. Thus, it was concluded that snug-tight bolts could be used in moment end-plate connections if prying forces are considered in the design model. Subsequently, Abel and Murray (1992b) showed that a yield-line/modified Kennedy method model accurately predicts the strength of the four-bolt, extended, unstiffened connection with snug-tight bolts.

Both the Research Council on Structural Connections *Specification for Structural Joints Using ASTM A325 or A490 Bolts* (2000) and *AISC Load and Resistance Factor Design Specification for Structural Steel Buildings* (1999) have adopted provisions to allow the use of snug-tight A325 bolts in end-plate connections and other bolts in tension that are not subject to fatigue loading.

1.2.3 Finite Element Analysis of Moment End-Plates

Research of moment end-plate connections utilizing finite element modeling has recently gained momentum from earlier, limited attempts. Krishnamurthy and Graddy (1976) attempted to calculate end-plate deformation for extended four-bolt connections, but computer size and speed limited the extent and mesh complexity of the early attempts of computer modeling of bolted connections. This research, and that of Kukreti, et al. (1987), made comparisons of 2D and 3D analyses for complexity and accuracy of representation. They concluded that, at the time, 2D analysis provided adequate reliable modeling of moment end-plate connections. Ahuja (1982) used finite element analysis to investigate the elastic properties of eight-bolt stiffened connections. The programming contained both 2D and 3D modeling elements for the connection. Ghassemieh (1983) continued the investigation of

Ahuja to include non-linear behavior of the end-plate and bolts. Kukreti, et al. (1990) continued finite element modeling for an eight-bolt connection and, as with previous research, conducted parametric studies to predict end-plate displacement and inner bolt forces. These predictions were compared to experimental data for correlation. Regression analysis of the data was conducted to provide empirical equations for design of moment end-plates under monotonic loads.

Use of the finite element code ABAQUS by Bursi and Leonelli (1994) aided in prediction of end-plate deformation and displacement for extended end-plates. The finite element code ANSYS has successfully been utilized by Bahaari and Sherbourne (1993) to model extended end-plates. Both codes have successfully produced three-dimensional modeling of the end-plates and provided valid predictions and analysis of both thick and thin plate behavior and deformation. Most finite element models of moment end-plate connections have analyzed monotonic loading, although Meng (1996) was successful in modeling a connection under seismic loading.

Advances in finite element research of moment end-plates are continuing at various universities, such as using 3D non-linear modeling to simulate hysteresis loop behavior and response due to varied loading. These responses are then used to predict component failure within end-plate connections.

1.2.4 Performance of Moment End-Plate Connections for Seismic Loading

Cyclic loading of moment end-plate connections was first studied by Popov and Tsai (1989). Since that time a number of studies have been conducted worldwide. Two studies that used design procedures similar to those in this Guide are Meng and Murray (1997) and Sumner, et al. (2000).

Meng and Murray (1997) conducted a series of tests using the four-bolt extended, unstiffened connection shown in Figure 1-4a. The connections were designed using the yield-line and modified Kennedy procedures that include prying force effects in the bolt design. The test specimens were designed such that the connection was stronger than the connected beam. Each specimen was subjected to the Applied Technology Council (ATC-24) protocol loading (ATC 1992). Even though bolt forces decreased from the fully tightened level (in some tests, even to zero) as the testing progressed, failure occurred in the beam for every test. If weld access holes were not used, robust hysteresis loops were obtained. In all the specimens tested with weld access holes, flange fracture at the weld access hole occurred a few cycles into the inelastic regime of the ATC-24 protocol. Subsequent finite element analysis showed that the presence of a weld access hole significantly increases flange strain adjacent to the hole. Meng and Murray recommended that weld access holes not be used in moment end-plate connections.

As part of the SAC Joint Venture, Sumner, et al. (2000) conducted beam-to-column tests using the *SAC Protocol* (1997). Their test matrix included the four-bolt extended, unstiffened end-plate connection. For each end-plate geometry, two tests were performed: one with the connection design to develop 110 percent of the nominal plastic moment strength of the beam (strong plate connection) and the other with the connection designed to develop 80 percent of the plastic moment strength of the beam (weak plate connection). It was found that the four-bolt extended, unstiffened end-plate connection can be designed and detailed to be suitable for seismic loading. A design procedure, very similar to the procedure contained in this Guide, was then developed. The procedure is found in the Federal Emergency Management Agency (FEMA) *Recommended Seismic Design Criteria for New Steel Moment-Frame Buildings* (2000).

Chapter 2

DESIGN PROCEDURES

2.1 Introduction

The design procedures for the four flush and five extended moment end-plate connections used in this Guide were developed at the University of Oklahoma and Virginia Polytechnic Institute and are based on a) yield-line theory, b) a method to predict bolt forces including prying effects, and c) moment-rotation considerations. More specifically the design procedures provide:

1. Determination of end-plate thickness by yield-line theory given end-plate geometry, beam geometry, and material yield stress; a strength criterion.
2. Determination of bolt forces including prying forces given end-plate geometry, bolt diameter, and bolt type; a bolt force criterion.
3. An assessment of construction type for which the connection is suitable; a stiffness criterion.

The procedures were verified using a series of full-scale tests of each of the nine connections shown in Figures 1-3 and 1-4 (Srouji, et al. 1983a, 1983b; Hendrick, et al. 1984, 1985; Morrison, et al. 1985, 1986; Abel and Murray 1992a, 1992b; and SEI 1984). The geometric parameters for each series were varied within limits determined from current practice of the low rise building industry.

The basis for each part of the design procedure is briefly described in the following sections. More thorough descriptions are found in the references cited.

2.2 Yield-Line Theory and Mechanics

Yield-lines are the continuous formation of plastic hinges along a straight or curved line. It is assumed that yield-lines divide a plate into rigid plane regions since elastic deformations are negligible when compared with plastic deformations. Although the failure mechanism of a plate using yield-line theory was initially developed for reinforced concrete, the principles and findings are also applicable to steel plates.

The analysis of a yield-line mechanism can be performed by two different methods, (1) the equilibrium method, or (2) the virtual work energy method. The latter method is more suitable for the end-plate application. In this method, the external work done by the applied load, in moving through a small arbitrary virtual deflection field, is equated to the internal work done as the plate rotates at the yield lines to facilitate this virtual deflection field. For a selected yield-line pattern and loading, specific plastic moment strength is required along these hinge lines. For the same loading, other patterns may re-

sult in larger required plastic moment strength. Hence, the appropriate pattern is the one, which requires the largest required plastic moment strength along the yield-lines. Conversely, for a given plastic moment strength along the yield-lines, the appropriate mechanism is that which produces the smallest ultimate load. This implies that the yield-line theory is an upper bound procedure; therefore, one must find the least upper bound.

The procedure to determine an end-plate plastic moment strength, or ultimate load, is to first arbitrarily select possible yield-line mechanisms. Next, the external work and internal work are equated, thereby establishing the relationship between the applied load and the ultimate resisting moment. This equation is then solved for either the unknown load or the unknown resisting moment. By comparing the values obtained from the arbitrarily selected mechanisms, the appropriate yield-line mechanism is the one with the largest required plastic moment strength or the smallest ultimate load.

The controlling yield-line mechanisms for each of the

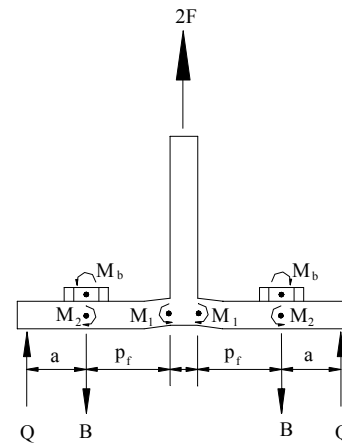
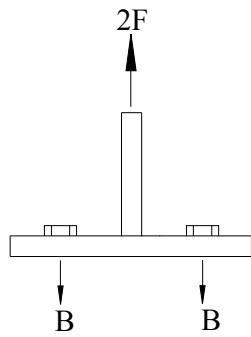

Figure 2-1 Split-tee model.

nine end-plate connections considered in this Guide are shown in Chapters 3 and 4.

2.3 Bolt Force Predictions

Yield-line theory does not provide bolt force predictions that include prying action forces. Since experimental test results indicate that prying action behavior is present in end-plate connections, a variation of the method suggested by Kennedy, et al. (1981) was adopted to predict bolt forces as a function of applied flange force.



(a) First Stage / Thick Plate Behavior

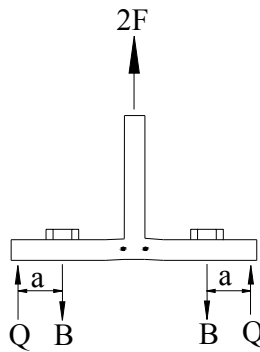

(b) Second Stage / Intermediate Plate Behavior

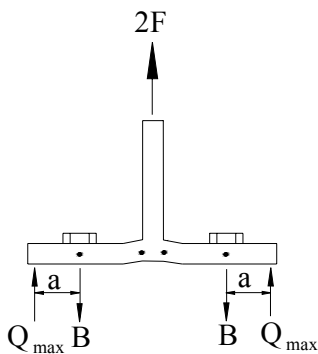

(c) Third Stage / Thin Plate Behavior

Figure 2-2 Flange behavior models.

The Kennedy method is based on the split-tee analogy and three stages of plate behavior. Consider a split-tee model, Figure 2-1, consisting of a flange bolted to a rigid support and attached to a web through which a tension load is applied.

At the lower levels of applied load, the flange behavior is termed “thick plate behavior”, as plastic hinges have

not formed in the split-tee flange, Figure 2-2a. As the applied load is increased, two plastic hinges form at the centerline of the flange and each web face intersection, Figure 2-2b. This yielding marks the “thick plate limit” and the transition to the second stage of plate behavior termed “intermediate plate behavior.” At a greater applied load level, two additional plastic hinges form at the centerline of the flange and each bolt, Figure 2-2c. The formation of this second set of plastic hinges marks the “thin plate limit” and the transition to the third stage of plate behavior termed “thin plate behavior.”

For all stages of plate behavior, the Kennedy method predicts a bolt force as the sum of a portion of the applied force and a prying force. The portion of the applied force depends on the applied load, while the magnitude of the prying force depends on the stage of plate behavior. For the first stage of behavior, or thick plate behavior, the prying force is zero. For the second stage of behavior, or intermediate plate behavior, the prying force increases from zero at the thick plate limit to a maximum at the thin plate limit. For the third stage of behavior, or thin plate behavior, the prying force is maximum and constant.

2.4 Moment-Rotation Relationships

Connection stiffness is the rotational resistance of a connection to applied moment. This connection characteristic is often described with a moment versus rotation or $M-\theta$ diagram. The initial slope of the $M-\theta$ curve, typically obtained from experimental test data, is an indication of the rotational stiffness of the connection, i.e. the greater the slope of the curve, the greater the stiffness of the connection.

This stiffness is reflected in the three types of construction defined in the *AISC Specification for Structural Steel Buildings -- Allowable Stress Design and Plastic Design* (1989): Type 1, Type 2, and Type 3. Type 1 construction, or rigid framing, assumes that the connections have sufficient rigidity to fully resist rotation at joints. Type 2 construction, or simple framing, assumes that the connections are free to rotate under gravity load and that beams are connected for shear only. Type 3 construction, or semi-rigid framing, assumes that connections have a dependable and known moment capacity as a function of rotation between that of Type 1 and Type 2 construction. The *AISC Load and Resistance Factor Design Specification for Structural Steel Buildings* (1999) defines two types of construction: FR and PR. Fully restrained or FR construction is the same as ASD Type 1 construction. Partially restrained or PR construction encompasses ASD Types 2 and 3 construction. Idealized $M-\theta$ curves for three typical connections representing the three AISC types of construction are shown in Figure 2-3. Note that the $M-\theta$ curve for an ideally fixed connection is one which traces the ordinate of the $M-\theta$ diagram, whereas the

M - θ curve for an ideally simple connection is one which traces the abscissa of the M - θ diagram.

For beams, guidelines have been suggested by Salmon and Johnson (1980), and Bjorhovde, et al. (1987,1990), to correlate M - θ connection behavior and AISC construction type. Traditionally, Type 1 or FR connections are required to carry an end moment greater than or equal to 90% of the full fixity end moment of the beam and not rotate more than 10% of the simple span rotation (Salmon and Johnson 1980). A Type 2 connection is allowed to resist an end moment not greater than 20% of the full fixity end moment and rotate at least 80% of the simple span beam end rotation. A Type 3 connection lies between the limits of the Type 1 and Type 2 connections. A PR connection is any connection that does not satisfy the FR requirements.

The simple span beam end rotation for any symmetrical loading is given by:

$$\theta_s = \frac{M_F L}{2EI} \quad (2-1)$$

where M_F = fixed end moment for the loading. Setting M_F equal to the yield moment of the beam, SF_y , and with $L/S = h/2$:

$$\theta_s = \frac{F_y L}{Eh} \quad (2-2)$$

Taking as a limit L/h equal to 24, and E equal to 29,000 ksi:

$$0.1(\theta_s) = 8.3 \times 10^{-5} F_y \text{ radians} \quad (2-3)$$

This value was used to determine the suitability of the moment end-plate connections considered in this Guide. It was found that 80% of the full moment capacity of the four flush connections and 100% of the full moment capacity of the five extended connections could be used in Type 1 or FR construction. It is noted that these classifications do not apply to seismic loading.

More recently, Bjorhovde, et al. (1987,1990) has suggested rotation criteria as a function of the connected beam span. Also, Hasan, et al. (1997) compared an experimental database of M - θ curves for 80 extended end-plate connection tests to the results of analyses of three frame configurations and concluded that almost all of the extended end-plate connections possessing initial stiffness $\geq 10^6$ kip-in/rad behave as rigid connections.

2.5 Design Procedures

Borgsmiller and Murray (1995) proposed a simplified method for the design of moment end-plate connections. The method uses yield-line analysis for determining end-plate thickness as discussed in Section 2.2. A simplified version of the modified Kennedy method was used to determine tension bolt forces including prying action effects. The bolt force calculations are reduced because only the maximum prying force is needed, eliminating the need to evaluate intermediate plate behavior prying forces. The primary assumption in this approach is that the end-plate must substantially yield to produce prying forces in the bolts. Conversely, if the plate is strong enough, no prying action occurs and the bolts are loaded in direct tension. This simplified approach also allows the designer to directly optimize either the bolt diameter or end-plate thickness as desired.

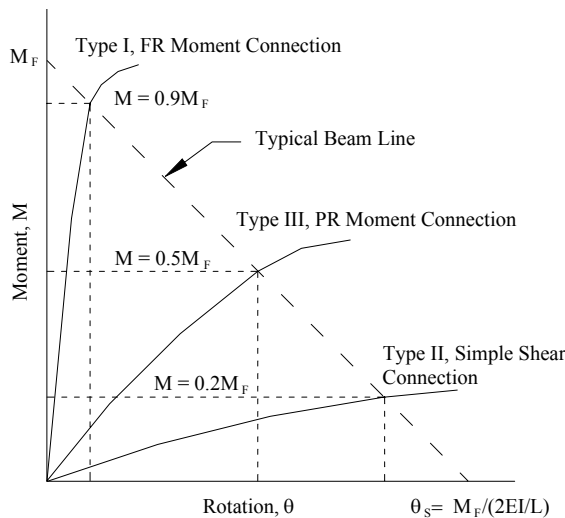

$$\text{Beam Line Equation, } M = M_F - 2EI\theta/L$$

where:

- M = beam line end-moment
- M_F = fixed end-moment, $(wL^2/12)$
- θ = beam line end-rotation
- θ_s = simple span beam end-rotation

Figure 2-3 Moment-rotation curves.

Specifically, Borgsmiller and Murray (1995) examined 52 tests and concluded that the threshold when prying action begins to take place in the bolts is at 90% of the full strength of the plate, or $0.90M_{pl}$. If the applied load is less than this value, the end-plate behaves as a thick plate and prying action can be neglected in the bolts. Once the applied moment crosses the threshold of $0.90M_{pl}$, the plate can be approximated as a thin plate and maximum prying action is incorporated in the bolt analysis.

The design procedures used in Chapter 3 for flush end-plates and in Chapter 4 for extended end-plates are based on the Borgsmiller and Murray (1995) approach. For a specific design, if it is desired to minimize bolt diameter, Design Procedure 1 is used. If it is desired to minimize the thickness of the end-plate, Design Procedure 2 is used. A flow chart is provided in Figure 2-4 that provides a summary of the design procedures outlined in Sections 2.5.1 and 2.5.2.

For LRFD designs, M_u is the required flexural strength (factored moment). For ASD designs the working moment or service load moment, M_w , is multiplied by 1.5 to obtain M_u . After determining M_u , the design procedures are exactly the same for ASD and LRFD.

2.5.1 Design Procedure 1:

Thick End-Plate and Smaller Diameter Bolts:

The following procedure results in a design with a relatively thick end-plate and smaller diameter bolts. The design is governed by bolt rupture with no prying action included, requiring "thick" plate behavior. The "summary tables" refer to Tables 3-2 through 3-5 for the flush end-plate connections and Tables 4-2 through 4-6 for the extended end-plate connections. The design steps are:

- 1.) Determine the required bolt diameter assuming no prying action,

$$d_{b,reqd} = \sqrt{\frac{2M_u}{\pi\phi F_t (\sum d_n)}} \quad (2-4)$$

where,

$$\phi = 0.75$$

F_t = bolt material tensile strength, specified in Table J3.2, AISC (1999), i.e. $F_t = 90$ ksi for A325 and $F_t = 113$ ksi for A490 bolts.

M_u = required flexural strength

d_n = distance from the centerline of the n^{th} tension bolt row to the center of the compression flange.

Note: This equation is derived from equating M_u to ϕM_{np} as shown in the "summary tables" in Chapter 3

for flush end-plates and Chapter 4 for extended end-plates as follows:

$$M_u = \phi M_{np} = \phi [2P_t (\sum d_n)] \quad (2-5)$$

Solving Equation 2-5 for P_t yields:

$$P_t = \frac{M_u}{2\phi (\sum d_n)} \quad (2-6)$$

Setting Equation 2-6 equal to the bolt proof load equation, $P_t = \frac{\pi d_b^2}{4} F_t$ and solving for d_b yields Equation 2-4.

- 2.) Solve for the required end-plate thickness, $t_{p,reqd}$,

$$t_{p,reqd} = \sqrt{\frac{(1.11)\gamma_r \phi M_{np}}{\phi_b F_{py} Y}} \quad (2-7)$$

where,

$$\phi_b = 0.90$$

γ_r = a factor, greater than or equal to 1.0, used to modify the required factored moment to limit the connection rotation at ultimate moment to 10% of the simple span rotation. (See Section 3.1.1 for further explanation)

= 1.25 for flush end-plates and 1.0 for extended end-plates

F_{py} = end-plate material yield strength

Y = yield-line mechanism parameter defined for each connection in the "summary tables" in Chapter 3 for flush end-plates and Chapter 4 for extended end-plates.

ϕM_{np} = connection strength with bolt rupture limit state and no prying action (Equation 2-5 based on selected bolt size).

Note: This equation is derived from equating ϕM_{np} to 90% of the design strength for end-plate yielding, $\phi_b M_{pl}$, given in the "summary tables" as follows:

$$\phi M_{np} = 0.90\phi_b M_{pl} = 0.90\phi_b F_{py} t_p^2 Y \quad (2-8)$$

Solving for t_p , along with the inclusion of the load factor γ_r , yields Equation 2-7. Note that the reciprocal of the 0.90 factor (1.11) is placed in the numerator to avoid confusion with the bending resistance factor ϕ_b of the same value.

2.5.2 Design Procedure 2:

Thin End-Plate and Larger Diameter Bolts:

The following procedure results in a design with a relatively thin end-plate and larger diameter bolts. The design is governed by either the yielding of the end-plate or bolt rupture when prying action is included, requiring "thin" plate behavior. The "summary tables" refer to Tables 3-2 through 3-5 for the flush end-plate connections and Tables 4-2 through 4-6 for the extended end-plate connections. The design steps are:

- 1.) Determine the required plate thickness,

$$t_{p,reqd} = \sqrt{\frac{\gamma_r M_u}{\phi_b F_{py} Y}} \quad (2-9)$$

Note: This equation is derived from equating $\gamma_r M_u$ to $\phi_b M_{pl}$ given in the "summary tables" as follows:

$$\gamma_r M_u = \phi_b M_{pl} = \phi_b F_{py} t_p^2 Y \quad (2-10)$$

- 2.) Select a trial bolt diameter, d_b , and calculate the maximum prying force.

For flush end-plate connections and for the interior bolts of extended end-plate connections, calculate $Q_{max,i}$ as follows:

$$Q_{max,i} = \frac{w' t_p^2}{4 a_i} \sqrt{F_{py}^2 - 3 \left(\frac{F'_i}{w' t_p} \right)^2} \quad (2-11)$$

where,

$$w' = b_p / 2 - (d_b + 1/16) \quad (2-12)$$

$$a_i = \boxed{3.682} \left(\frac{t_p}{d_b} \right)^3 - 0.085 \quad (2-13)$$

$$F'_i = \frac{t_p^2 F_{py} \left(0.85 \frac{b_p}{2} + 0.80 w' \right) + \frac{\pi d_b^3 F_t}{8}}{4 p_{f,i}} \quad (2-14)$$

Note that for flush connections $p_{f,i} = p_f$. Also, the last term in the numerator of Equation 2-14 represents the contribution of bolt shank bending (M_b in Figure 2-1).

For extended connections, also calculate $Q_{max,o}$, based on the outer bolts as follows:

$$Q_{max,o} = \frac{w' t_p^2}{4 a_o} \sqrt{F_{py}^2 - 3 \left(\frac{F'_o}{w' t_p} \right)^2} \quad (2-15)$$

where,

$$a_o = \frac{\boxed{3.682} \left(\frac{t_p}{d_b} \right)^3 - 0.085}{\min \left[P_{ext} - P_{f,o} \right]} \quad (2-16)$$

$$F'_o = \frac{t_p^2 F_{py} \left(0.85 \frac{b_p}{2} + 0.80 w' \right) + \frac{\pi d_b^3 F_t}{8}}{4 p_{f,o}} \quad (2-17)$$

If the radical in either expression for Q_{max} (Equations 2-11 and 2-15) is negative, combined flexural and shear yielding of the end-plate is the controlling limit state and the end-plate is not adequate for the specified moment.

- 3.) Calculate the connection design strength for the limit state of bolt rupture with prying action as follows:

For a flush connection:

$$\phi M_q = \begin{cases} \phi [2(P_t - Q_{max,i})(d_1 + d_2)] \\ \phi [2(T_b)(d_1 + d_2)] \end{cases} \quad (2-18)$$

For an extended connection:

$$\phi M_q = \begin{cases} \phi [2(P_t - Q_{max,o})d_0 + 2(P_t - Q_{max,i})(d_1 + d_3) + 2T_b d_2] \\ \phi [2(P_t - Q_{max,o})d_0 + 2T_b(d_1 + d_2 + d_3)] \\ \phi [2(P_t - Q_{max,i})(d_1 + d_3) + 2T_b(d_0 + d_2)] \\ \phi [2T_b(d_0 + d_1 + d_2 + d_3)] \end{cases} \quad (2-19)$$

where,

$$\phi = 0.75$$

$$P_t = \pi d_b^2 F_t / 4$$

d_i = distance from the Centerline of each tension bolt row to the center of the compression flange (Note: For rows that do not exist in a connection, that distance d is taken as zero),

T_b = specified pretension in Table J3.7 of AISC ASD or Table J3.1 of AISC LRFD (also reproduced in Table 2-1 of this Guide).

Rev.
3/1/03

Rev.
3/1/03

Rev.
3/1/03

Note: For A325 snug-tightened bolts, the following values of T_b should be used:

- $d_b \leq 5/8$ in., $T_b = 75\%$ of minimum bolt pretension
- $d_b = 3/4$ in., $T_b = 50\%$ of minimum bolt pretension
- $d_b = 7/8$ in., $T_b = 37.5\%$ of minimum bolt pretension
- $d_b \geq 1$ in., $T_b = 25\%$ of minimum bolt pretension

- 4.) Check that $\phi M_q > M_u$. If necessary, adjust the bolt diameter until ϕM_q is greater than M_u .

Table 2-1 Minimum Bolt Pretension, T_b (kips)

Bolt Size (in.)	A325	A490
1/2	12	15
5/8	19	24
3/4	28	35
7/8	39	49
1	51	64
1 1/8	56	80
1 1/4	71	102
1 3/8	85	121
1 1/2	103	148

2.5.3 Additional Assumptions and Conditions

The following assumptions or conditions are inherent in the design procedures:

1. Snug-tight bolts should not be used for other than static loading conditions. Temperature, wind, and snow loads are considered static loadings. End-plate connections with snug-tight bolts are not recommended for members subjected to large fatigue loading conditions such as heavy crane runways, and supporting structures for machinery and equipment. AISC and RCSC only permit A325 bolts to be snug-tightened (A490 bolts must be fully tightened).
2. The required factored moment for plate design, M_u , should be increased by $\gamma_r = 1.25$ for flush end-plate connections if they are assumed to be rigid frame construction as explained in Chapter 3. $\gamma_r = 1.00$ for extended connections.
3. Requirements beyond the scope of this Guide must be considered when designing end-plate connections for geographic areas of high seismicity. Pending further research, snug-tight bolts are not recommended for these applications.
4. The smallest possible pitch distance, p_f , (distance from face of beam flange to centerline of nearer bolt) generally results in the most economical connection. The absolute minimum pitch dimension for standard bolts is bolt diameter plus 1/2 in. for bolts up to 1 in. diameter and bolt diameter plus 3/4 in. for larger diameter bolts. For ten-

sion control bolts, larger pitch distances are required.

5. End-plate connections can be designed to resist shear force at the interface of the end-plate and column flange using either “bearing” or “slip critical” assumptions. Slip critical connections are only required for other than static loading conditions (see item 1 above). When fully tightened or snug-tight bearing type connections are used, it is common practice to assume that the compression bolts resist all of the shear force. When slip critical (type “SC”) are necessary, all bolts at the interface can be assumed to resist the shear force and shear/tension interaction can be ignored as explained in the *Commentary on Specification for Structural Joints Using ASTM A325 or A490 Bolts* (RCSC 1985). This Commentary states: “Connections of the type...in which some of the bolts lose a part of their clamping force due to applied tension suffer no overall loss of frictional resistance. The bolt tension produced by the moment is coupled with a compensating compressive force on the other side of the axis of bending.” Thus, the frictional resistance of the connection remains unchanged. If a bearing type connection is used, it is common practice to assume that the compression bolts resist all of the shear force.
6. The width of the end-plate, which is effective in resisting the applied beam moment, shall not be taken greater than the beam flange width plus 1 inch in the calculations.
7. The gage of the tension bolts (horizontal distance between vertical bolt lines) should not exceed the beam tension flange width.
8. Normally, the beam flange to end-plate weld is designed to develop the yield strength of the connected beam flange. This is usually done with full penetration welds but alternatively, fillet welds may be used for thin flanges. When the applied moment is less than the design flexural strength of the beam, the beam flange to end-plate weld can be designed for the required moment strength but not less than 60 percent of the specified minimum yield strength of the connected beam flange.
9. Beam web to end-plate welds in the vicinity of the tension bolts are to be designed to develop the yield strength of the beam web unless the full design strength of the beam is not required. When the full design strength is not required, the beam web to end-plate welds should be designed to develop 60 percent of the minimum specified yield strength of the beam web.
10. For beam shear resistance in the web at the end-plate, only the distance between the mid-depth of

the beam and the inside face of the beam compression flange, or between the inner row of tension bolts plus two bolt diameters and the inside face of the beam compression flange, whichever is smaller, shall be used. This assumption is based on engineering judgment; literature was not found to substantiate or contradict this assumption.

11. To the writers' knowledge, tests of end-plate moment connections with axial forces have not been conducted. Inclusion of axial forces in an end-plate yield-line analysis results in an effective end-plate moment equal to the applied moment plus (tension) or minus (compression) the axial force times one-half the beam depth. See Example 4.2.3 for the design procedure modified to include an axial load.
12. Stitch bolts are sometimes used between the tension and compression flange end-plate bolts, especially in deep connections. The purpose of these bolts is to reduce plate separation caused by welding distortions. Because stitch bolts are located near the center of gravity of the member, the contribution to connection strength is small and is neglected.
13. Web and web stiffener design is not included in the design procedures in this Guide. Most end-plate strength tests have been conducted with relatively thick webs to avoid premature web failure. In a number of tests, beam webs near the tension bolts have been instrumented with strain gages with yielding of the beam web plate reported. Pending further testing, engineering judgment is required to determine required web and web stiffener size.
14. Column web stiffening (transverse stiffeners or continuity plates and panel zone doubler plates) design is not included in this Design Guide. AISC Design Guide No. 4 - Extended End-Plate Moment Connections (Murray 1990) contains column stiffening design recommendations. Also, see AISC Design Guide No. 13 – Stiffening of Wide-Flange Columns at Moment Connections: Wind and Seismic Applications (Carter 1999) for additional guidance.

2.6 Limit States Check List

Limit states (or failure modes) that should be considered in the design of moment end-plate beam-to-column connections are:

1. Flexural yielding of the end-plate material near the tension flange bolts. This state in itself is not limiting, but yielding results in rapid increases in tension bolt forces and excessive rotation.
2. Shear yielding of the end-plate material. This limit state is not usually observed, but shear in combination with bending can result in reduced flexural capacity and stiffness.
3. Shear rupture of end-plate through outside bolt holes.
4. Bolt rupture because of direct load and prying force effects. This limit state is obviously a brittle failure mode and is the most critical limit state in an end-plate connection.
5. Bolt rupture or bolt slip in a slip-critical connection due to shear at the interface between the end-plate and column flange.
6. Bearing failure of end-plate or column flange at bolts.
7. Rupture of beam tension flange to end-plate welds or beam web tension region to end-plate welds.
8. Shear yielding of beam web to end-plate weld or of beam web base metal.
9. Column web yielding opposite either the tension or compression flanges of the connected beam.
10. Column web crippling opposite the compression flange of the connected beam.
11. Column web buckling opposite the compression flange of the connected beam.
12. Column flange yielding in the vicinity of the tension bolts. As with flexural yielding of the end-plate, this state in itself is not limiting but results in rapid increases in tension bolt forces and excessive rotation.
13. Column transverse stiffener failure due to yielding, local buckling, or weld failure.
14. Column panel zone failure due to shear yielding or web plate buckling.
15. Excessive rotation (flexibility) at the connection due to end-plate and/or column flange bending.

Given: Beam & end plate geometry, connection moment.

Find: Connection plate thickness and bolt diameter.

(See Appendix A for Nomenclature)

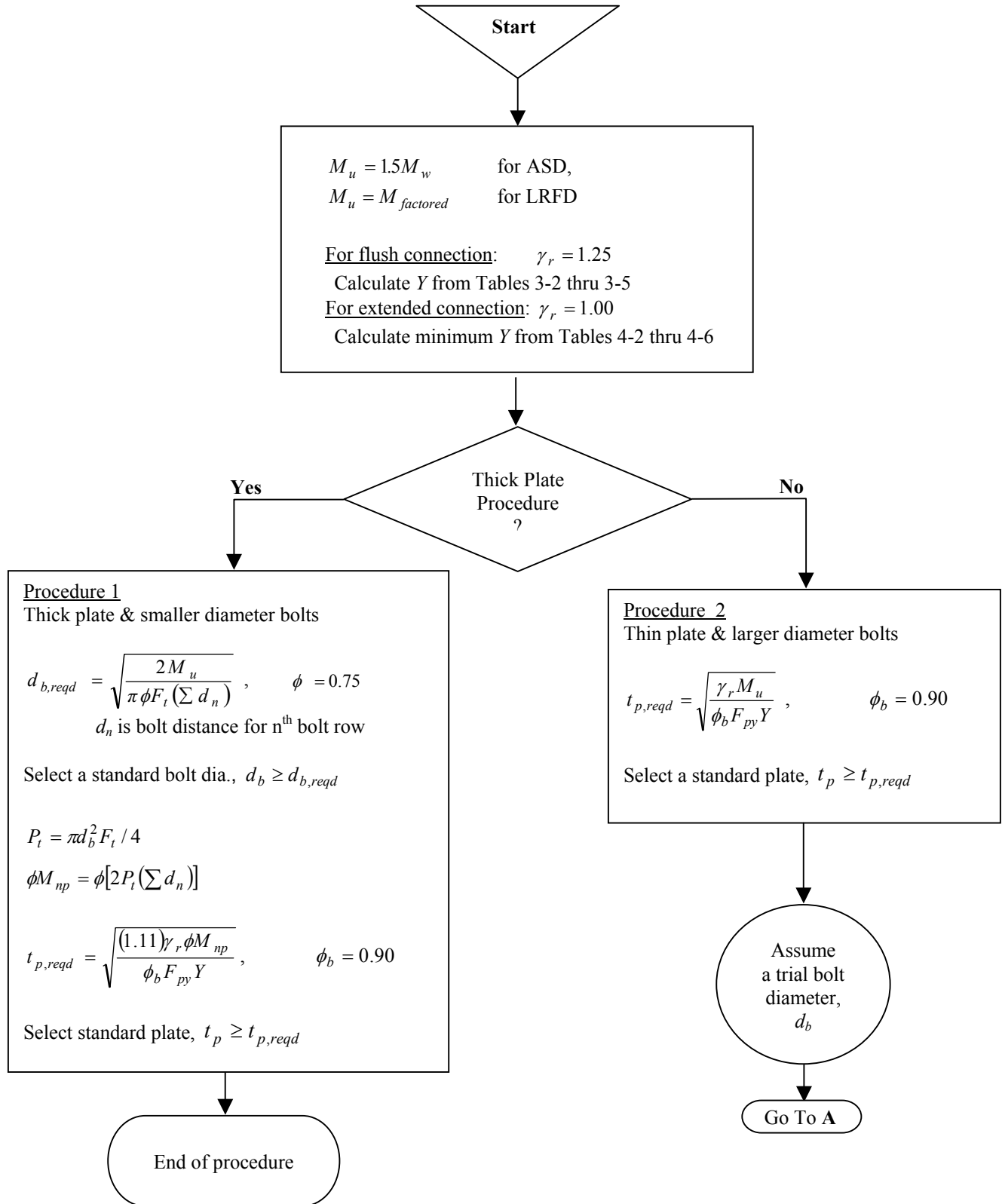

Figure 2-4 Flow-Chart: Bolted end-plate connection design.

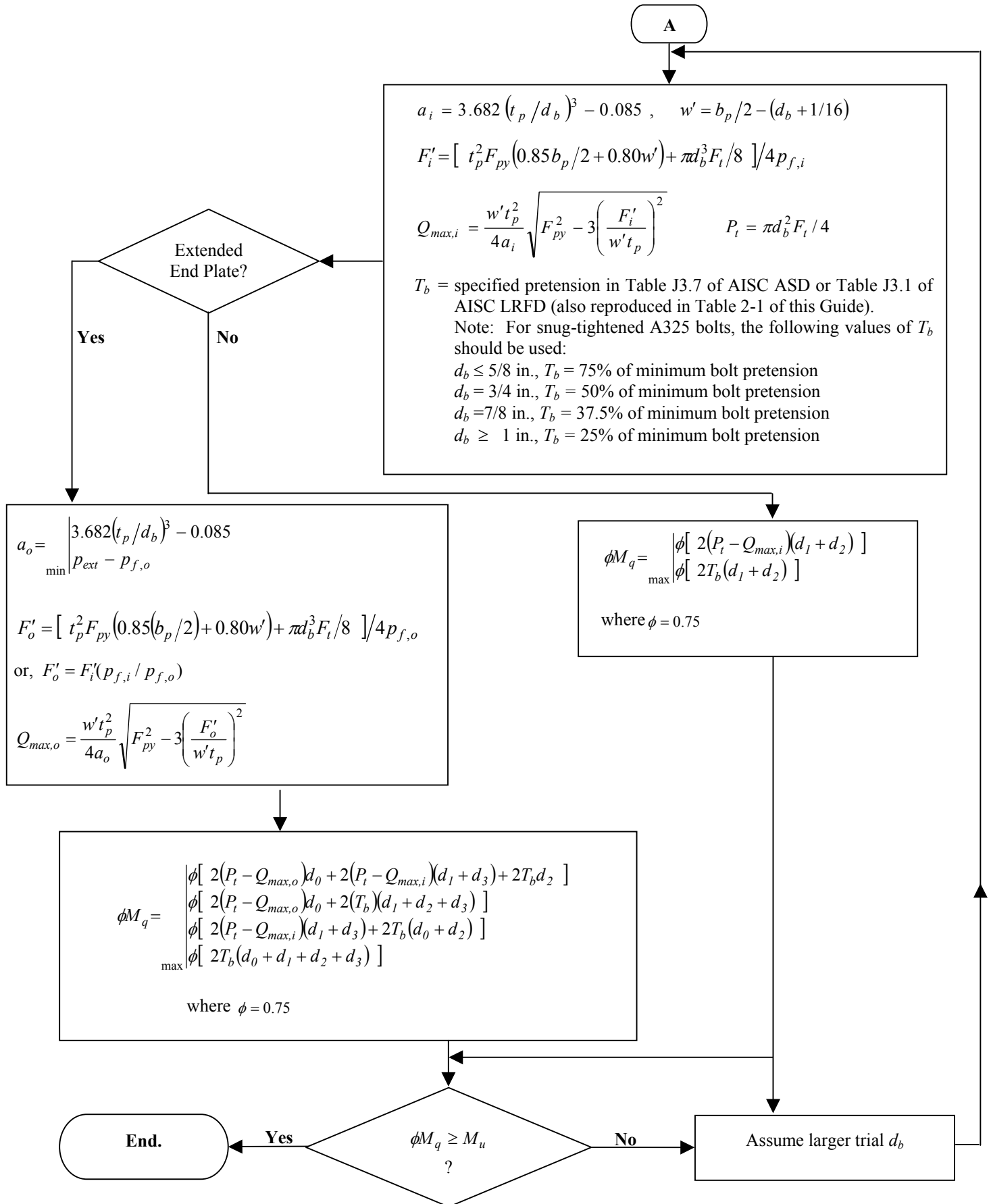

Figure 2-4 (Continued) Flow-Chart: Bolted end-plate connection design

Chapter 3

FLUSH END-PLATE DESIGN

3.1 Design Equations, Limitations, and Definitions

3.1.1 Design Equations

The design procedures described in Section 2.5 are used in this Chapter for the design of the four-bolt flush end-plate configurations shown in Figure 1-3. Equations required for determination of bolt forces are found in Table 3-1. Controlling yield-line patterns and the remaining design equations are found in Tables 3-2 through 3-5 for the four configurations.

The expression for Q_{max} in Table 3-1 contains terms in a radical. If the quantity inside the radical is negative, combined flexural and shear yielding of the end-plate is the controlling limit state and the end-plate is not adequate for the specified moment. A thicker end-plate is thus required.

For either ASD Type 1 or LRFD FR rigid frame construction, the required factored moment, M_u , must be increased 25% to limit the connection rotation at ultimate moment to 10% of the simple span beam rotation. Therefore, the factor $\gamma_r = 1.25$ is used in the procedure for the flush connection plate design.

Connections can be designed using either pretensioned or snug-tight bolts. For fully tightened bolts, the pretension force, T_b in Table 3-1, is the specified force in Table J3.7 of the AISC ASD Specification or Table J3.1 of the AISC LRFD Specification (also, see Table 2-1 of this Guide for these specified minimum pretension forces). For snug-tightened A325 bolts, the pretension force, T_b , is taken as a percentage of the AISC specified pretension force of Table J3.7 (AISC ASD) or Table J3.1 (AISC LRFD) as indicated in Table 3-1.

3.1.2 Limitations

The analytical procedures were verified through tests, Srouji *et al.* (1983a, 1983b), and Hendrick *et al.* (1984, 1985), in which geometric parameters were varied among the test configurations. Significant changes in the geometric relationships could affect the mechanism configuration and thus the predicted strength. Therefore, the tested parameter ranges given in Table 3-6 apply to the design equations for the flush end-plate configurations.

3.1.3 Definitions

The definitions of the principal variables in Tables 3-1 through 3-5 follow. Definitions for other variables are in Appendix A.

$$P_t = \text{bolt tensile strength} = \text{bolt proof load} = A_b F_t$$

$$T_b = \text{bolt pretension force}$$

$$Q_{max} = \text{maximum possible bolt prying force}$$

$$M_n = \text{nominal strength of connection}$$

$$M_{pl} = \text{nominal connection strength for the limit state of end-plate yielding}$$

$$M_q = \text{nominal connection strength for the limit state of bolt fracture with prying action}$$

$$M_{np} = \text{nominal connection strength for the limit state of bolt fracture with no prying action}$$

$$w' = \text{effective width of end-plate per bolt minus the bolt hole diameter}$$

Table 3-1 Summary of Bolt Force Prediction Equations for Flush End-Plate Connections

Bolt Proof Load	$P_t = A_b F_t = \frac{\pi d_b^2}{4} F_t$ $F_t = \text{nominal tensile strength of bolts}$ $= 90 \text{ ksi for A325}$ $= 113 \text{ ksi for A490}$ <p>(Table J3.2, AISC LRFD Specification)</p>
Bolt Pretension	<p><u>Fully-tightened bolts</u> $T_b =$ specified pretension force in Table J3.1, AISC LRFD Specification for fully tightened bolts (ASD Table J3.7).</p> <p><u>Snug-tightened A325 bolts</u> T_b is taken as the following percentage of the AISC specified full pretension given in Table J3.1, AISC LRFD Specification (ASD Table J3.7)</p> $d_b \leq 5/8 \text{ in.}, \text{ use } 75\%$ $d_b = 3/4 \text{ in.}, \text{ use } 50\%$ $d_b = 7/8 \text{ in.}, \text{ use } 37.5\%$ $d_b \geq 1 \text{ in.}, \text{ use } 25\%$
Maximum Prying Force ¹	$Q_{max,i} = \frac{w' t_p^2}{4 a_i} \sqrt{F_{py}^2 - 3 \left(\frac{F'_i}{w' t_p} \right)^2}$ <p>where,</p> $a_i = 3.682 \left(\frac{t_p}{d_b} \right)^3 - 0.085$ $w' = b_p / 2 - (d_b + 1/16)$ $F'_i = \frac{t_p^2 F_{py} \left(0.85 \frac{b_p}{2} + 0.80 w' \right) + \frac{\pi d_b^3 F_t}{8}}{4 p_{f,i}}$
<p>¹ If the radical in the expression for Q_{max} is negative, combined flexural and shear yielding of the end-plate is the controlling limit state and the end-plate is not adequate for the specified moment.</p>	

Table 3-2 Summary of Two-Bolt Flush Unstiffened Moment End-Plate Analysis

Geometry	Yield-Line Mechanism	Bolt Force Model
		
<p>End-Plate Yield</p>	$\phi M_n = \phi_b M_{pl} = \phi_b F_y A_p Y$ $Y = \frac{b_p}{2} \left[h_1 \left(\frac{I}{p_f s} + \frac{I}{s} \right) + \frac{2}{g} [h_1 (p_f + s)] \right]$ $s = \frac{1}{2} \sqrt{b_p g} \quad \phi_b = 0.90$ <p>Note: Use $p_f = s$, if $p_f > s$</p>	
<p>Bolt Rupture w/Prying Action</p>	$\phi M_n = \phi M_q = \max \left[\phi [2(P_t - Q_{max}) d_1], \phi [2(T_b) d_1] \right]$ $\phi = 0.75$	
<p>Bolt Rupture No Prying Action</p>	$\phi M_n = \phi M_{np} = \phi [2(P_t) d_1]$ $\phi = 0.75$	

Table 3-3 Summary of Four-Bolt Flush Unstiffened Moment End-Plate Analysis

Geometry	Yield-Line Mechanism	Bolt Force Model
		
<p>End-Plate Yield</p>	$\phi M_n = \phi_b M_{pl} = \phi_b F_{yp} f_p^2 Y$ $Y = \frac{b_p}{2} \left[h_1 \left(\frac{1}{p_f} \right) + h_2 \left(\frac{1}{s} \right) \right] + \frac{2}{g} [h_1(p_f + 0.75p_b) + h_2(s + 0.25p_b)] + \frac{g}{2}$ $s = \frac{1}{2} \sqrt{b_p g} \quad \phi_b = 0.90$	<p>Note: Use $p_f = s$, if $p_f > s$</p>
<p>Bolt Rupture w/Prying Action</p>	$\phi M_n = \phi M_q = \left \frac{2(P_t - Q_{max})(d_1 + d_2)}{\phi [2(T_b)(d_1 + d_2)]} \right \quad \phi = 0.75$	
<p>Bolt Rupture No Prying Action</p>	$\phi M_n = \phi M_{np} = \phi [2(P_t)(d_1 + d_2)] \quad \phi = 0.75$	

Table 3-4 Summary of Four-Bolt Flush Stiffened Moment End-Plate Analysis (Stiffened Between the Tension Bolt Rows)

Geometry	Yield-Line Mechanism	Bolt Force Model
		
<p>End-Plate Yield</p>	$\phi M_n = \phi_b M_{pl} = \phi_b F_{yp} f_p^2 Y$ $Y = \frac{b_p}{2} \left[h_1 \left(\frac{1}{p_f} + \frac{1}{p_{s,o}} \right) + h_2 \left(\frac{1}{s} + \frac{1}{p_{s,i}} \right) \right] + \frac{2}{g} [h_1(p_f + p_{s,o}) + h_2(s + p_{s,i})]$ $s = \frac{1}{2} \sqrt{b_p g} \quad \phi_b = 0.90$	<p>Note: Use $p_f = s$, if $p_f > s$</p>
<p>Bolt Rupture w/Prying Action</p>	$\phi M_n = \phi M_q = \frac{\phi [2(P_t - Q_{max})(d_1 + d_2)]}{\max} \phi [2(T_b)(d_1 + d_2)]$ $\phi = 0.75$	
<p>Bolt Rupture No Prying Action</p>	$\phi M_n = \phi M_{np} = \phi [2(P_t)(d_1 + d_2)]$ $\phi = 0.75$	

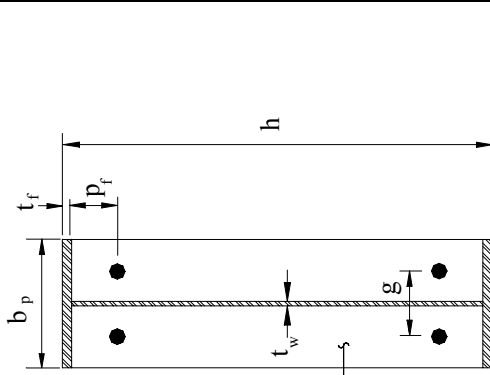
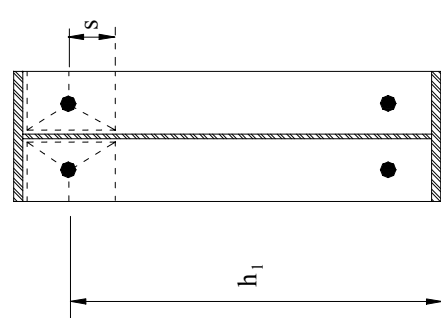
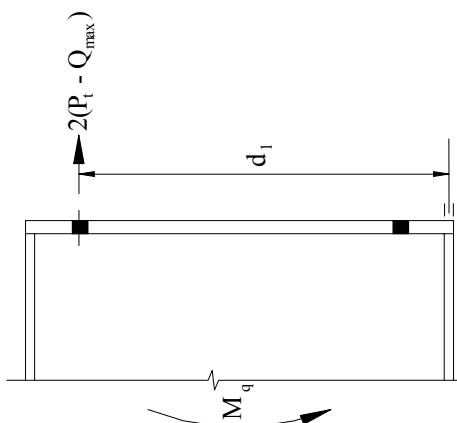
Table 3-5 Summary of Four-Bolt Flush Stiffened Moment End-Plate Analysis (Stiffened Inside the Tension Bolt Rows)

Geometry	Yield-Line Mechanism	Bolt Force Model
		
End-Plate Yield	$\phi M_n = \phi_b M_{pl} = \phi_b F_y p_f^2 Y$ $Y = \frac{b_p}{2} \left[h_1 \left(\frac{1}{p_f} \right) + h_2 \left(\frac{1}{s} \right) \right] + \frac{2}{g} [h_1(p_f + 0.75p_b) + h_2(s + 0.25p_b)] + \frac{g}{2}$ $s = \frac{1}{2} \sqrt{b_p g} \leq p_s \quad (\text{Note upper bound on } s \text{ for this connection}) \quad \phi_b = 0.90$	Note: Use $p_f = s$, if $p_f > s$
Bolt Rupture w/Prying Action	$\phi M_n = \phi M_q = \frac{\phi [2(P_t - Q_{max})(d_1 + d_2)]}{\max[\phi [2(T_b)(d_1 + d_2)]]}$	$\phi = 0.75$
Bolt Rupture No Prying Action	$\phi M_n = \phi M_{np} = \phi [2(P_t)(d_1 + d_2)]$	$\phi = 0.75$

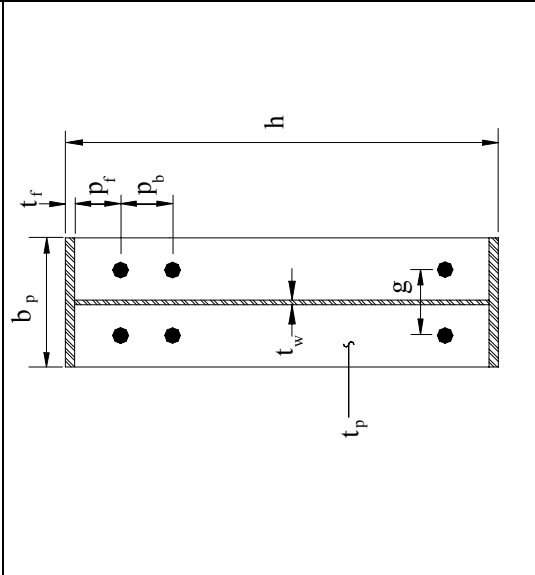
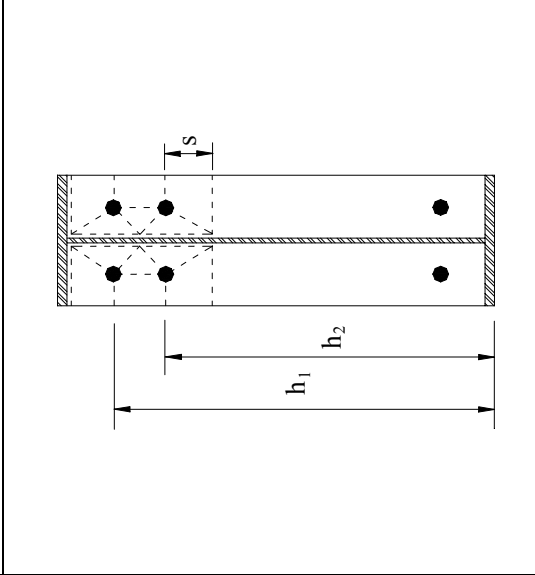
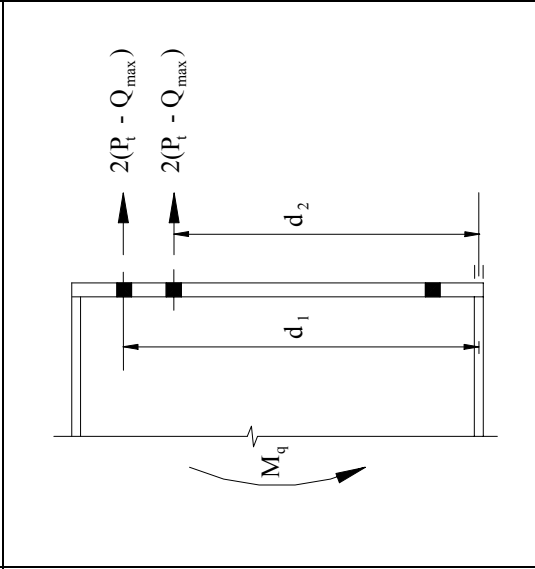
Table 3-6 Tested Parameter Range for Flush End-Plate Connections

Parameter	Low (in.)	High (in.)
p_f	$1 \frac{5}{16}$	$1 \frac{7}{8}$
p_b	$1 \frac{7}{8}$	3
g	$2 \frac{1}{4}$	$3 \frac{3}{4}$
h	16 ^(a)	24
b_p	5	6
t_f	$\frac{3}{16}$	$\frac{3}{8}$

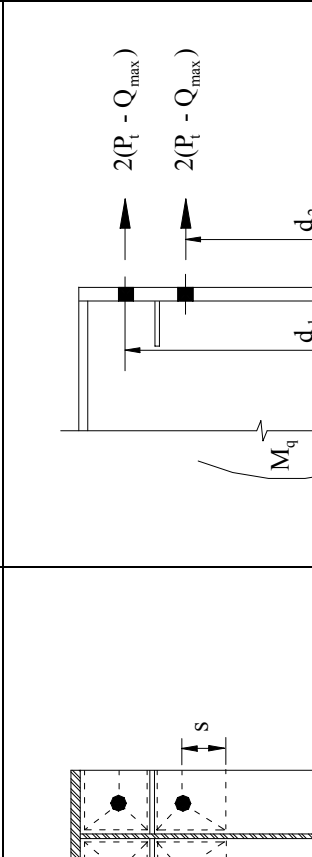
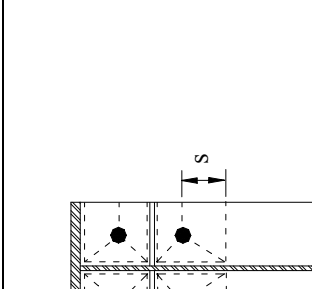
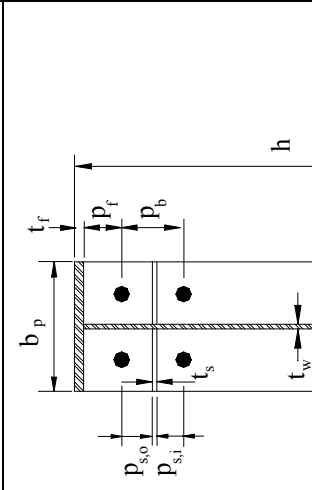
^aFor the two-bolt flush connection, the lower limit for depth is 8 in.

3.2 Design Examples

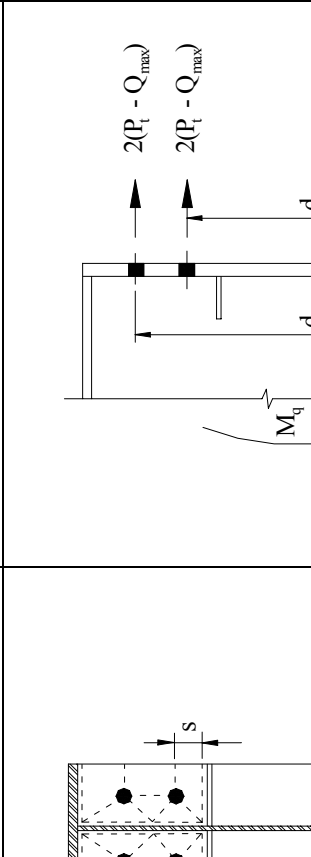
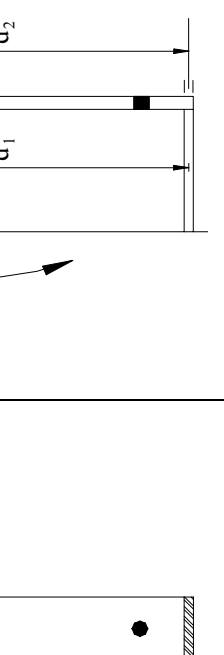
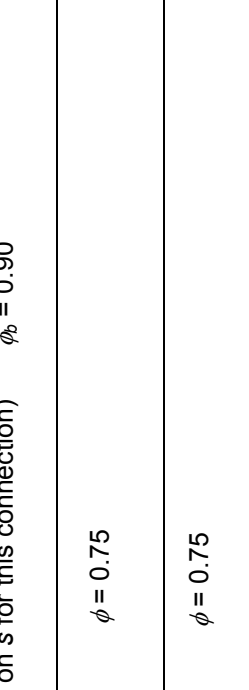
The following design examples are in the LRFD format. The same procedures apply for ASD design if the ASD moments are first converted to ultimate by multiplying times 1.5, or factored moments as explained in Section 2.5.

3.2.1 Two-Bolt Flush Unstiffened Moment End-Plate Connection (Table 3-2)

The required end-plate thickness and bolt diameter for an end-plate connection with the geometry shown below is to be determined for a required factored moment of 600 k-in.

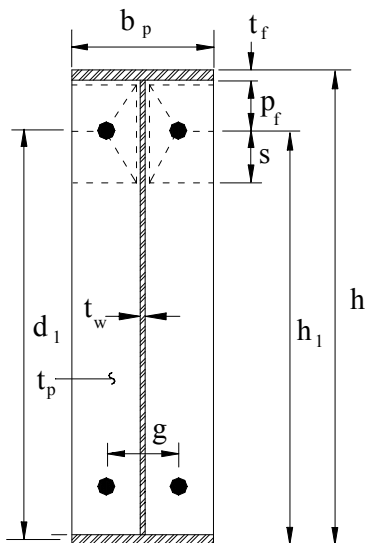

The end-plate material is A572 Gr 50, the bolts are snug-tightened A325, and the connection is to be used in rigid frame construction as assumed in the frame analysis. Both design procedures are illustrated.

Geometric Design Data

$$\begin{aligned} b_p &= b_f = 6 \text{ in.} \\ t_f &= 1/4 \text{ in.} \\ g &= 2 \ 3/4 \text{ in.} \\ p_f &= 1 \ 3/8 \text{ in.} \\ h &= 18 \text{ in.} \end{aligned}$$

Calculate:

$$\begin{aligned} d_l &= 18 - 0.25 - 1.375 - (0.25/2) = 16.25 \text{ in.} \\ h_l &= 16.375 \text{ in.} \\ \gamma_r &= 1.25 \text{ for flush connections} \end{aligned}$$

Design Procedure 1 (Thick End-Plate and Smaller Diameter Bolts):

1.) Solve for the required bolt diameter assuming no prying action,

$$\begin{aligned} d_{b,reqd} &= \sqrt{\frac{2M_u}{\pi\phi F_t (\sum d_n)}} = \sqrt{\frac{2(600)}{\pi(0.75)(90)(16.25)}} \\ &= 0.59 \text{ in.} \end{aligned}$$

Use $d_b = 5/8$ in.

2.) Solve for the required end-plate thickness, $t_{p,reqd}$,

$$s = \frac{1}{2} \sqrt{b_p g} = \frac{1}{2} \sqrt{6.0(2.75)} = 2.03 \text{ in.}$$

$$p_f = 1.375 \text{ in.} \leq s \therefore \text{use } p_f = 1.375 \text{ in.}$$

$$\begin{aligned} Y &= \frac{b_p}{2} \left[h_l \left(\frac{1}{p_f} + \frac{1}{s} \right) \right] + \frac{2}{g} [h_l (p_f + s)] \\ &= \frac{6.0}{2} \left[16.375 \left(\frac{1}{1.375} + \frac{1}{2.03} \right) \right] \\ &\quad + \frac{2}{2.75} [16.375(1.375 + 2.03)] = 100.5 \text{ in.} \end{aligned}$$

$$P_t = \pi d_b^2 F_t / 4 = \pi (0.625)^2 (90) / 4 = 27.6 \text{ k}$$

$$\begin{aligned} \phi M_{np} &= \phi [2P_t (\sum d_n)] = 0.75 [2(27.6)(16.25)] \\ &= 673 \text{ k-in.} \end{aligned}$$

$$\begin{aligned} t_{p,reqd} &= \sqrt{\frac{1.11 \gamma_r (\phi M_{np})}{\phi_b F_{py} Y}} = \sqrt{\frac{1.11(1.25)(673)}{(0.90)(50)(100.5)}} \\ &= 0.45 \text{ in.} \end{aligned}$$

Use $t_p = 1/2$ in.

<p>Summary: $t_p = 1/2$ in. $d_b = 5/8$ in.</p>
--

Design Procedure 2 (Thin End-Plate and Larger Diameter Bolts):

1.) Determine the required plate thickness,

$$t_{p,reqd} = \sqrt{\frac{\gamma_r M_u}{\phi_b F_{py} Y}} = \sqrt{\frac{1.25(600)}{0.90(50)(100.5)}} = 0.41 \text{ in.}$$

Use $t_p = 7/16$ in.

2.) Select a trial bolt diameter, d_b , and calculate the maximum prying force, $Q_{max,i}$.

Try $d_b = 0.75$ in.

$$w' = b_p / 2 - (d_b + 1/16) = (6.0 / 2) - (0.75 + 1/16) = 2.19 \text{ in.}$$

$$a_i = 3.682(t_p / d_b)^3 - 0.085 = 3.682(0.4375 / 0.75)^3 - 0.085 = 0.65 \text{ in.}$$

$$F'_i = \frac{t_p^2 F_{py} \left[0.85 \left(\frac{b_p}{2} \right) + 0.80 w' \right] + \frac{\pi d_b^3 F_t}{8}}{4 p_{f,i}}$$

$$= \frac{0.4375^2 (50) \left[0.85 \left(\frac{6.0}{2} \right) + 0.80 (2.19) \right] + \frac{\pi (0.75)^3 90}{8}}{4 (1.375)}$$

$$= 10.2 \text{ k}$$

$$Q_{max,i} = \frac{w' t_p^2}{4 a_i} \sqrt{F_{py}^2 - 3 \left(\frac{F'_i}{w' t_p} \right)^2}$$

$$= \frac{2.19 (0.4375)^2}{4 (0.65)} \sqrt{(50)^2 - 3 \left(\frac{10.2}{2.19 (0.4375)} \right)^2}$$

$$= 7.49 \text{ k}$$

3.) Calculate the connection design strength for the limit state of bolt rupture with prying action,

$$\phi M_q = \max \left\{ \begin{array}{l} \phi [2(P_t - Q_{max}) d_l] \\ \phi [2(T_b) d_l] \end{array} \right.$$

$$P_t = \pi d_b^2 F_t / 4 = \pi (0.75)^2 (90) / 4 = 39.8 \text{ k}$$

For snug-tight bolts, T_b is 50% of Table J3.1 pretension = $0.50(28) = 14 \text{ k}$

$$\phi M_q = \max \left\{ \begin{array}{l} 0.75 [2(39.8 - 7.49)(16.25)] = 788 \text{ k-in.} \\ 0.75 [2(14)(16.25)] = 341 \text{ k-in.} \end{array} \right.$$

4.) Check that $\phi M_q > M_u$. If necessary, adjust the bolt diameter until ϕM_q is greater than M_u .

$$\phi M_q = 788 > 600 \text{ k-in. so the trial bolt, } 3/4 \text{ in dia. is ok.}$$

Note: A check (not shown) of 5/8 in. bolt confirms that 3/4 in. is required.

<p>Summary: $t_p = 7/16$ in. $d_b = 3/4$ in.</p>

Comparison of Results for the Two Design Procedures

Design Procedure 1

End-Plate: A572 Gr 50 material

$$t_p = 1/2 \text{ in.}$$

Bolts: A325

$$d_b = 5/8 \text{ in.}$$

Design Procedure 2

End-Plate: A572 Gr 50 material

$$t_p = 7/16 \text{ in.}$$

Bolts: A325

$$d_b = 3/4 \text{ in.}$$

As expected, Design Procedure 1 results in a thicker end-plate and smaller diameter bolts than Design Procedure 2. Either design is acceptable. Note: A check of the design strength of the two designs using the procedure outlined in Appendix B yields the following:

Design Procedure 1: $\phi M_n = 673 \text{ k-in.}$ (Thick plate behavior controlled by bolt rupture – no prying action) Design Procedure 2: $\phi M_n = 693 \text{ k-in.}$ (Thin plate behavior controlled by end-plate yielding)

3.2.2 Four-Bolt Flush Unstiffened Moment End-Plate Connection (Table 3-3)

In this four-bolt flush unstiffened example, the required factored moment of 600 k-in. and connection geometry of the two-bolt flush unstiffened connection of Example 3.2.1 is used so that the required end-plate thicknesses and bolt diameters can be compared. As before, the end-plate material is A572 Gr 50, the bolts are snug-tightened

A325, and the connection is used in rigid frame construction as assumed in the frame analysis. Both LRFD design procedures are illustrated.

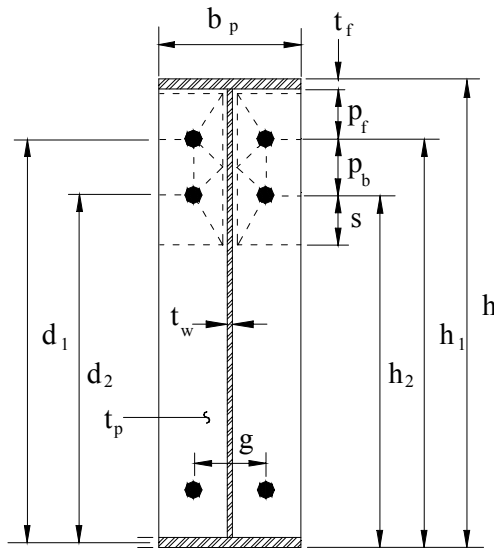

Geometric Design Data

- $b_p = b_f = 6 \text{ in.}$
- $t_f = 1/4 \text{ in.}$
- $g = 2 \text{ } 3/4 \text{ in.}$
- $p_f = 1 \text{ } 3/8 \text{ in.}$
- $p_b = 3 \text{ in.}$
- $h = 18 \text{ in}$

Calculate:

- $d_1 = 18 - 1.625 - (0.25/2) = 16.25 \text{ in.},$
- $h_1 = 16.375$
- $d_2 = 18 - 1.625 - (0.25/2) - 3 = 13.25 \text{ in.},$
- $h_2 = 13.375$
- $\gamma_r = 1.25 \text{ for flush connections}$

Design Procedure 1 (Thick End-Plate and Smaller Diameter Bolts):

1.) Solve for the required bolt diameter assuming no prying action,

$$d_{b,reqd} = \sqrt{\frac{2M_u}{\pi\phi F_t (\sum d_n)}} = \sqrt{\frac{2(600)}{\pi(0.75)(90)(16.25 + 13.25)}} = 0.44 \text{ in.}$$

Use $d_b = 1/2 \text{ in.}$

2.) Solve for the required end-plate thickness, $t_{p,reqd}$,

$$s = \frac{1}{2} \sqrt{b_p g} = \frac{1}{2} \sqrt{6.0(2.75)} = 2.03 \text{ in.}$$

$p_f = 1.375 \text{ in.} \leq s \therefore \text{use } p_f = 1.375 \text{ in.}$

$$Y = \frac{b_p}{2} \left(\frac{h_1}{p_f} + \frac{h_2}{s} \right) + \frac{2}{g} [h_1(p_f + 0.75p_b) + h_2(s + 0.25p_b)] + \frac{g}{2}$$

$$= \frac{6.0}{2} \left(\frac{16.375}{1.375} + \frac{13.375}{2.03} \right) + \frac{2}{2.75} [16.375(1.375 + 0.75(3.0)) + 13.375(2.03 + 0.25(3.0))] + \frac{2.75}{2}$$

$$= 127.1 \text{ in.}$$

$$P_t = \pi d_b^2 F_t / 4 = \pi(0.50)^2 (90) / 4 = 17.7 \text{ k}$$

$$\phi M_{np} = \phi [2P_t (\sum d_n)] = 0.75 [2(17.7)(16.25 + 13.25)] = 783 \text{ k-in.}$$

$$t_{p,reqd} = \sqrt{\frac{1.11\gamma_r(\phi M_{np})}{\phi_b F_{py} Y}} = \sqrt{\frac{1.11(1.25)(783)}{(0.90)(50)(127.1)}} = 0.436 \text{ in.}$$

Use $t_p = 7/16 \text{ in.}$

<p>Summary:</p> <p>$t_p = 7/16 \text{ in.}$</p> <p>$d_b = 1/2 \text{ in.}$</p>

Design Procedure 2 (Thin End-Plate and Larger Diameter Bolts):

1.) Determine the required plate thickness,

$$t_{p,reqd} = \sqrt{\frac{\gamma_r M_u}{\phi_b F_{py} Y}} = \sqrt{\frac{1.25(600)}{0.90(50)(127.1)}} = 0.36 \text{ in.}$$

Use $t_p = 3/8 \text{ in.}$

2.) Select a trial bolt diameter, d_b , and calculate the maximum prying force, $Q_{max,i}$.

Try $d_b = 1/2 \text{ in.}$

$$w' = b_p / 2 - (d_b + 1/16)$$

$$= (6.0 / 2) - (0.50 + 1/16) = 2.44 \text{ in.}$$

$$a_i = 3.682(t_p / d_b)^3 - 0.085$$

$$= 3.682(0.375 / 0.50)^3 - 0.085 = 1.47 \text{ in.}$$

$$F'_i = \frac{t_p^2 F_{py} \left[0.85 \left(\frac{b_p}{2} \right) + 0.80 w' \right] + \frac{\pi d_b^3 F_t}{8}}{4 p_{f,i}}$$

$$= \frac{0.375^2 (50) \left[0.85 \left(\frac{6.0}{2} \right) + 0.80 (2.44) \right] + \frac{\pi (0.50)^3 90}{8}}{4 (1.375)}$$

$$= 6.56 \text{ k}$$

$$Q_{max,i} = \frac{w' t_p^2}{4 a_i} \sqrt{F_{py}^2 - 3 \left(\frac{F'_i}{w' t_p} \right)^2}$$

$$= \frac{2.44 (0.375)^2}{4 (1.47)} \sqrt{(50)^2 - 3 \left(\frac{6.56}{2.44 (0.375)} \right)^2}$$

$$= 2.83 \text{ k}$$

- 3.) Calculate the connection design strength for the limit state of bolt rupture with prying action,

$$\phi M_q = \max \left\{ \begin{array}{l} \phi [2(P_t - Q_{max})(d_1 + d_2)] \\ \phi [2(T_b)(d_1 + d_2)] \end{array} \right.$$

$$P_t = \pi d_b^2 F_t / 4 = \pi (0.50)^2 (90) / 4 = 17.7 \text{ k}$$

For snug-tight bolts, T_b is 75% of Table J3.1 pretension = 0.75(12) = 9 k

$$\phi M_q = \max \left\{ \begin{array}{l} 0.75 [2(17.7 - 2.83)(16.25 + 13.25)] = 658 \text{ k-in.} \\ 0.75 [2(9)(16.25 + 13.25)] = 398 \text{ k-in.} \end{array} \right.$$

- 4.) Check that $\phi M_q > M_u$. If necessary, adjust the bolt diameter until ϕM_q is greater than M_u .

$$\phi M_q = 658 > 600 \text{ k-in. so the trial bolt,}$$

1/2 in. dia. is ok.

<p><u>Summary:</u> $t_p = 3/8 \text{ in.}$ $d_b = 1/2 \text{ in.}$</p>

Comparison of Results for the Two Design Procedures

Design Procedure 1

End-Plate: A572 Gr 50 material

$$t_p = 7/16 \text{ in.}$$

Bolts: A325

$$d_b = 1/2 \text{ in.}$$

Design Procedure 2

End-Plate: A572 Gr 50 material

$$t_p = 3/8 \text{ in.}$$

Bolts: A325

$$d_b = 1/2 \text{ in.}$$

In this example, Design Procedure 2 produces a more economic design since both methods require the same nominal bolt diameter. Different limit states govern the design strengths using the procedure outlined in Appendix B as follows:

Design Procedure 1: $\phi M_n = 783 \text{ k-in.}$ (Thick plate behavior controlled by bolt rupture – no prying action)

Design Procedure 2: $\phi M_n = 643 \text{ k-in.}$ (Thin plate behavior controlled by end-plate yielding)

3.2.3 Four-Bolt Flush Stiffened Moment End-Plate Connection (Stiffener Between Bolt Rows, Table 3-4)

The required end-plate thickness and bolt diameter for an end-plate connection with the geometry shown in the figure below and a required factored moment of 900 k-in. is

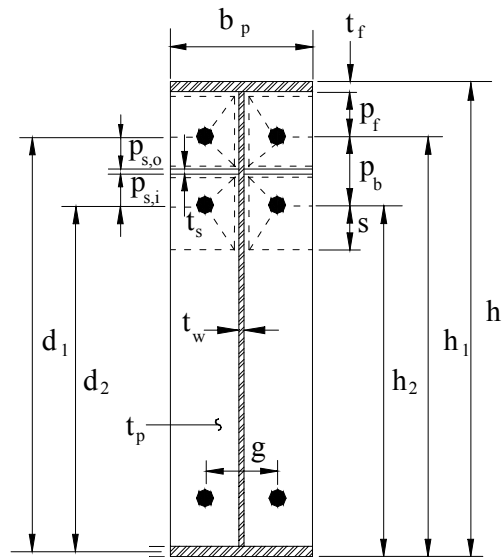

to be determined. The end-plate material is A572 Gr 50, the bolts are fully pretensioned A325, and the connection is used in rigid frame construction as assumed in the frame analysis. Both LRFD design procedures are illustrated.

Geometric Design Data

$$\begin{aligned}
b_p &= b_f = 6 \text{ in.} \\
t_f &= 1/4 \text{ in.} \\
g &= 3 \text{ in.} \\
p_f &= 1 \ 1/2 \text{ in.} \\
p_b &= 3 \text{ in.} \\
p_{s,o} &= 1 \ 3/8 \text{ in.} \\
t_s &= 3/8 \text{ in.} \\
h &= 16 \text{ in.}
\end{aligned}$$

Calculate:

$$\begin{aligned}
d_l &= 16 - 1.5 - (0.25/2) = 14.125 \text{ in.} \\
d_2 &= 16 - 1.5 - (0.25/2) - 3 = 11.125 \text{ in.} \\
h_l &= 14.25 \text{ in.} \\
h_2 &= 11.25 \text{ in.} \\
p_{s,i} &= p_b - p_{s,o} - t_s = 3 - 1.375 - 0.375 = 1.25 \text{ in.} \\
\gamma_r &= 1.25 \text{ for flush connections}
\end{aligned}$$

Design Procedure 1 (Thick End-Plate and Smaller Diameter Bolts):

1.) Solve for the required bolt diameter assuming no prying action,

$$\begin{aligned}
d_{b,reqd} &= \sqrt{\frac{2M_u}{\pi\phi F_t (\sum d_n)}} \\
&= \sqrt{\frac{2(900)}{\pi(0.75)(90)(14.125 + 11.125)}} = 0.58 \text{ in.}
\end{aligned}$$

Use $d_b = 5/8 \text{ in.}$

2.) Solve for the required end-plate thickness, $t_{p,reqd}$,

$$s = \frac{1}{2} \sqrt{b_p g} = \frac{1}{2} \sqrt{6.0(3.0)} = 2.12 \text{ in.}$$

$p_f = 1.5 \text{ in.} \leq s \therefore$ Use $p_f = 1.5 \text{ in.}$

$$\begin{aligned}
Y &= \frac{b_p}{2} \left[h_l \left(\frac{1}{p_f} + \frac{1}{p_{s,o}} \right) + h_2 \left(\frac{1}{s} + \frac{1}{p_{s,i}} \right) \right] \\
&\quad + \frac{2}{g} [h_1(p_f + p_{s,o}) + h_2(s + p_{s,i})] \\
&= \frac{6.0}{2} \left[14.25 \left(\frac{1}{1.5} + \frac{1}{1.375} \right) + 11.25 \left(\frac{1}{2.12} + \frac{1}{1.25} \right) \right] \\
&\quad + \frac{2}{3.0} [14.25(1.5 + 1.375) + 11.25(2.12 + 1.25)] \\
&= 155.1 \text{ in.}
\end{aligned}$$

$$P_t = \pi d_b^2 F_t / 4 = \pi(0.625)^2(90) / 4 = 27.6 \text{ k}$$

$$\begin{aligned}
\phi M_{np} &= \phi [2P_t (\sum d_n)] = 0.75 [2(27.6)(14.125 + 11.125)] \\
&= 1045 \text{ k-in.}
\end{aligned}$$

$$t_{p,reqd} = \sqrt{\frac{1.11\gamma_r(\phi M_{np})}{\phi_b F_{py} Y}} = \sqrt{\frac{1.11(1.25)(1045)}{(0.90)(50)(155.1)}} = 0.46 \text{ in.}$$

Use $t_p = 1/2 \text{ in.}$

Summary:	$t_p = 1/2 \text{ in.}$
	$d_b = 5/8 \text{ in.}$

Design Procedure 2 (Thin End-Plate and Larger Diameter Bolts):

1.) Determine the required plate thickness,

$$t_{p,reqd} = \sqrt{\frac{\gamma_r M_u}{\phi_b F_{py} Y}} = \sqrt{\frac{1.25(900)}{0.90(50)(155.1)}} = 0.40 \text{ in.}$$

Use $t_p = 7/16 \text{ in.}$

2.) Select a trial bolt diameter, d_b , and calculate the maximum prying force, $Q_{max,i}$.

Try $d_b = 3/4 \text{ in.}$

$$\begin{aligned}
w' &= b_p / 2 - (d_b + 1/16) \\
&= (6.0 / 2) - (0.75 + 1/16) = 2.19 \text{ in.}
\end{aligned}$$

$$\begin{aligned}
a_i &= 3.682(t_p / d_b)^3 - 0.085 \\
&= 3.682(0.4375 / 0.75)^3 - 0.085 = 0.65 \text{ in.}
\end{aligned}$$

$$\begin{aligned}
F'_i &= \frac{t_p^2 F_{py} \left[0.85 \left(\frac{b_p}{2} \right) + 0.80w' \right] + \frac{\pi d_b^3 F_t}{8}}{4p_{f,i}} \\
&= \frac{0.4375^2 (50) \left[0.85 \left(\frac{6.0}{2} \right) + 0.80(2.19) \right] + \frac{\pi(0.75)^3 90}{8}}{4(1.5)} \\
&= 9.35 \text{ k}
\end{aligned}$$

$$\begin{aligned}
Q_{max,i} &= \frac{w' t_p^2}{4a_i} \sqrt{F_{py}^2 - 3 \left(\frac{F'_i}{w' t_p} \right)^2} \\
&= \frac{2.19(0.4375)^2}{4(0.65)} \sqrt{(50)^2 - 3 \left(\frac{9.35}{2.19(0.4375)} \right)^2} \\
&= 7.59 \text{ k}
\end{aligned}$$

- 3.) Calculate the connection design strength for the limit state of bolt rupture with prying action,

$$\phi M_q = \max \left\{ \begin{array}{l} \phi [2(P_t - Q_{max})(d_1 + d_2)] \\ \phi [2(T_b)(d_1 + d_2)] \end{array} \right.$$

$$P_t = \pi d_b^2 F_t / 4 = \pi (0.75)^2 (90) / 4 = 39.8 \text{ k}$$

$$T_b \approx 0.7P_t = 0.7(39.8) = 27.9 \text{ k}, \text{ or from Table J3.1,}$$

Use $T_b = 28 \text{ k}$

$$\phi M_q = \max \left\{ \begin{array}{l} 0.75 [2(39.8 - 7.59)(14.125 + 11.125)] = 1220 \text{ k-in} \\ 0.75 [2(28)(14.125 + 11.125)] = 1061 \text{ k-in.} \end{array} \right.$$

- 4.) Check that $\phi M_q > M_u$. If necessary, adjust the bolt diameter until ϕM_q is greater than M_u .

$$\phi M_q = 1220 > 900 \text{ k-in. so the trial bolt,}$$

3/4 in dia. is ok.

Note: A check (not shown) of 5/8 in. bolt confirms that 3/4 in. is required.

<p><u>Summary:</u></p> <p>$t_p = 7/16 \text{ in.}$ $d_b = 3/4 \text{ in.}$</p>

Comparison of Results for the Two Design Procedures

Design Procedure 1

End-Plate: A572 Gr 50 material

$$t_p = 1/2 \text{ in.}$$

Bolts: A325

$$d_b = 5/8 \text{ in.}$$

Design Procedure 2

End-Plate: A572 Gr 50 material

$$t_p = 7/16 \text{ in.}$$

Bolts: A325

$$d_b = 3/4 \text{ in.}$$

As expected, Design Procedure 1 results in a thicker end-plate and smaller diameter bolts than Design Procedure 2. Either design is acceptable. Note: A check of the design strength of the two designs using the procedure outlined in Appendix B yields the following:

Design Procedure 1: $\phi M_n = 1045 \text{ k-in.}$ (Thick plate behavior controlled by bolt rupture – no prying action)

Design Procedure 2: $\phi M_n = 1069 \text{ k-in.}$ (Thin plate behavior controlled by end-plate yielding)

3.2.4 Four-Bolt Flush Stiffened Moment End-Plate Connection (Stiffener Inside Bolt Rows, Table 3-5)

The required end-plate thickness and bolt diameter for the end-plate geometry shown is to be determined. The same required factored moment, of 900 k-in., and connection geometry of Example 3.2.3 are to be used. The only difference between these examples is the location of the stiffener. As before, the end-plate material is A572 Gr 50, the bolts are fully pretensioned A325, and the connection is used in rigid frame construction. Both LRFD design procedures are illustrated.

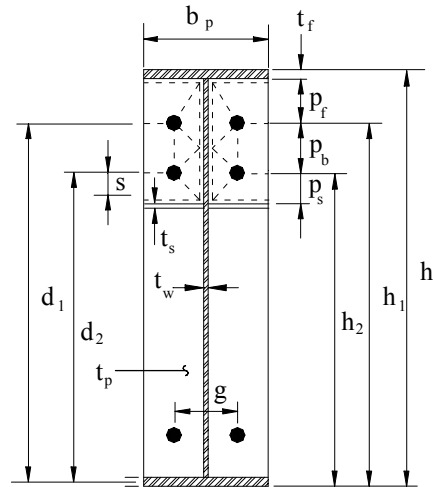

Geometric Design Data

$$b_p = b_f = 6 \text{ in.}$$

$$t_f = 1/4 \text{ in.}$$

$$g = 3 \text{ in.}$$

$$p_f = 1 \ 1/2 \text{ in.}$$

$$p_b = 3 \text{ in.}$$

$$h = 16 \text{ in.}$$

$$p_s = 1 \ 1/2 \text{ in.}$$

Calculate:

$$d_1 = 16 - 1.5 - (0.25/2) = 14.125 \text{ in.}$$

$$d_2 = 16 - 1.5 - (0.25/2) - 3 = 11.125 \text{ in.}$$

$$h_1 = 14.25 \text{ in}$$

$$h_2 = 11.25 \text{ in}$$

$$\gamma_r = 1.25 \text{ for flush connections}$$

Design Procedure 1 (Thick End-Plate and Smaller Diameter Bolts):

- 1.) Solve for the required bolt diameter assuming no prying action,

$$d_{b,reqd} = \sqrt{\frac{2M_u}{\pi\phi F_t (\sum d_n)}} = \sqrt{\frac{2(900)}{\pi(0.75)(90)(14.125 + 11.125)}} = 0.58 \text{ in.}$$

Use $d_b = 5/8$ in.

2.) Solve for the required end-plate thickness, $t_{p,reqd}$,

$$s = \frac{1}{2}\sqrt{b_p g} = \frac{1}{2}\sqrt{6.0(3.0)} = 2.12 \text{ in.} > p_s = 1.5 \text{ in.}$$

∴ Use $s = 1.5$ in.

$$p_f = 1.5 \text{ in.} \leq s \text{ ∴ Use } p_f = 1.5 \text{ in.}$$

$$Y = \frac{b_p}{2} \left[h_1 \left(\frac{1}{p_f} \right) + h_2 \left(\frac{1}{s} \right) \right] + \frac{2}{g} \left[h_1 (p_f + 0.75p_b) + h_2 (s + 0.25p_b) \right] + \frac{g}{2}$$

$$Y = \frac{6.0}{2} \left[\left(\frac{14.25}{1.5} \right) + \left(\frac{11.25}{1.5} \right) \right] + \frac{2}{3.0} \left[14.25(1.5 + 0.75(3.0)) + 11.25(1.5 + 0.25(3.0)) \right] + \frac{3.0}{2} = 105.0 \text{ in.}$$

$$P_t = \pi d_b^2 F_t / 4 = \pi(0.625)^2 (90) / 4 = 27.6 \text{ k}$$

$$\phi M_{np} = \phi [2P_t (\sum d_n)] = 0.75 [2(27.6)(14.125 + 11.125)] = 1045 \text{ k-in.}$$

$$t_{p,reqd} = \sqrt{\frac{1.11\gamma_r (\phi M_{np})}{\phi_b F_{py} Y}} = \sqrt{\frac{1.11(1.25)(1045)}{(0.90)(50)(105)}} = 0.55 \text{ in.}$$

Use $t_p = 9/16$ in.

Summary:	$t_p = 9/16$ in. $d_b = 5/8$ in.
-----------------	-------------------------------------

Design Procedure 2 (Thin End-Plate and Larger Diameter Bolts):

1.) Determine the required plate thickness,

$$t_{p,reqd} = \sqrt{\frac{\gamma_r M_u}{\phi_b F_{py} Y}} = \sqrt{\frac{1.25(900)}{0.90(50)(105)}} = 0.49 \text{ in.}$$

Use $t_p = 1/2$ in.

2.) Select a trial bolt diameter, d_b , and calculate the maximum prying force, $Q_{max,i}$.

Try $d_b = 5/8$ in.

$$w' = b_p / 2 - (d_b + 1/16) = (6.0 / 2) - (0.625 + 1/16) = 2.31 \text{ in.}$$

$$a_i = 3.682(t_p / d_b)^3 - 0.085 = 3.682(0.50 / 0.625)^3 - 0.085 = 1.80 \text{ in.}$$

$$F'_i = \frac{t_p^2 F_{py} \left[0.85 \left(\frac{b_p}{2} \right) + 0.80w' \right] + \frac{\pi d_b^3 F_t}{8}}{4p_{f,i}} = \frac{0.50^2 (50) \left[0.85 \left(\frac{6.0}{2} \right) + 0.80(2.31) \right] + \frac{\pi(0.625)^3 90}{8}}{4(1.5)} = 10.6 \text{ k}$$

$$Q_{max,i} = \frac{w' t_p^2}{4a_i} \sqrt{F_{py}^2 - 3 \left(\frac{F'_i}{w' t_p} \right)^2} = \frac{2.31(0.50)^2}{4(1.80)} \sqrt{(50)^2 - 3 \left(\frac{10.6}{2.31(0.50)} \right)^2} = 3.80 \text{ k}$$

3.) Calculate the connection design strength for the limit state of bolt rupture with prying action,

$$\phi M_q = \max \left\{ \begin{array}{l} \phi [2(P_t - Q_{max})(d_1 + d_2)] \\ \phi [2(T_b)(d_1 + d_2)] \end{array} \right.$$

$$P_t = \pi d_b^2 F_t / 4 = \pi(0.625)^2 (90) / 4 = 27.6 \text{ k}$$

$$T_b \approx 0.7P_t = 0.7(27.6) = 19.3 \text{ k, or from Table J3.1, Use } T_b = 19 \text{ k}$$

$$\phi M_q = \max \begin{cases} 0.75[2(27.6 - 3.80)(14.125 + 11.125)] = 901 \text{ k-in} \\ 0.75[2(19)(14.125 + 11.125)] = 720 \text{ k-in} \end{cases}$$

4.) Check that $\phi M_q > M_u$. If necessary, adjust the bolt diameter until ϕM_q is greater than M_u .

$\phi M_q = 901 > 900$ kip-in. so the trial bolt,

5/8 in. dia. is ok.

Summary: $t_p = 1/2$ in.
 $d_b = 5/8$ in.

Comparison of Results for the Two Design Procedures

Design Procedure 1

End-Plate: A572 Gr 50 material

$t_p = 9/16$ in.

Bolts: A325

$d_b = 5/8$ in.

Design Procedure 2

End-Plate: A572 Gr 50 material

$t_p = 1/2$ in.

Bolts: A325

$d_b = 5/8$ in.

In this example, Design Procedure 2 produces a more economic design since both methods require the same nominal bolt diameter. Different limit states govern the design strengths using the procedure outlined in Appendix B as follows:

Design Procedure 1: $\phi M_n = 1045$ k-in. (Thick plate behavior controlled by bolt rupture – no prying action)

Design Procedure 2: $\phi M_n = 901$ k-in. (Thin plate behavior controlled by bolt rupture with prying)

Chapter 4

EXTENDED END-PLATE DESIGN

4.1 Design Equations, Limitations, and Definitions

4.1.1 Design Equations

The design procedures described in Section 2.5 are used in this Chapter for the design of the five extended end-plate configurations shown in Figure 1-4. Equations required for determination of bolt forces are found in Table 4-1. Controlling yield-line patterns and the remaining design equations are found in Tables 4-2 through 4-6 for the five configurations.

The expressions for $Q_{max,i}$ and $Q_{max,o}$ in Table 4-1 contain terms in a radical. If the quantity inside the radical is negative, combined flexural and shear yielding of the end-plate is the controlling limit state and the end-plate is not adequate for the specified moment, therefore, a thicker end-plate is required.

Connections using either pretensioned or snug-tight bolts can be designed. For fully tightened bolts, the pretension force, T_b in Table 4-1, is the specified force in Table J3.7 of the AISC ASD Specification or Table J3.1 of the AISC LRFD Specification (also, see Table 2.1 of this Guide for these specified minimum pretension forces). For snug-tightened A325 bolts, the pretension force, T_b , is taken as a percentage of the AISC specified pretension force of Table J3.7 (AISC ASD) or Table J3.1 (AISC LRFD) as indicated in Table 4-1.

4.1.2 Limitations

The analytical procedures were verified through tests, Morrison, et al. (1985, 1986), Abel and Murray (1992a, 1992b), and SEI (1984), in which geometric parameters were varied among the test configurations. Significant changes in the geometric relationships could effect the mechanism configuration and thus the predicted strength. Therefore, the tested parameter ranges given in Table 4-7 apply to the design equations for the extended end-plate configurations.

4.1.3 Definitions

The definitions of the principal variables in Tables 4-1 through 4-6 follow. Definitions for other variables are in Appendix A.

$$P_t = \text{bolt tensile strength} = \text{bolt proof load} = A_b F_t$$

$$T_b = \text{bolt pretension force}$$

$$Q_{max,i} = \text{maximum possible bolt prying force in the tension bolts between the beam flanges}$$

$$Q_{max,o} = \text{maximum possible bolt prying force in the tension bolts outside the beam flanges}$$

$$M_n = \text{nominal strength of connection}$$

$$M_{pl} = \text{nominal connection strength for the limit state of end-plate yielding}$$

$$M_q = \text{nominal connection strength for the limit state of bolt fracture with prying action}$$

$$M_{np} = \text{nominal connection strength for the limit state of bolt fracture with no prying action}$$

$$w' = \text{effective width of end-plate per bolt minus the bolt hole diameter}$$

Table 4-1 Summary of Bolt Force Prediction Equations for Extended End-Plate Connections

Bolt Proof Load	$P_t = A_b F_t = \frac{\pi d_b^2}{4} F_t$ $F_t = \text{nominal tensile strength of bolts}$ $= 90 \text{ ksi for A325}$ $= 113 \text{ ksi for A490}$ (Table J3.2, AISC LRFD Specification)
Bolt Pretension	<u>Fully-tightened bolts</u> $T_b =$ specified pretension force in Table J3.1, AISC LRFD Specification for fully tightened bolts (ASD Table J3.7). <u>Snug-tightened A325 bolts</u> T_b is taken as the following percentage of the AISC specified full pretension given in Table J3.1, AISC LRFD Specification (ASD Table J3.7) $d_b \leq 5/8 \text{ in.}, \text{ use } 75\%$ $d_b = 3/4 \text{ in.}, \text{ use } 50\%$ $d_b = 7/8 \text{ in.}, \text{ use } 37.5\%$ $d_b \geq 1 \text{ in.}, \text{ use } 25\%$
Inside Bolt Rows Maximum Prying Force	$Q_{max,i} = \frac{w' t_p^2}{4 a_i} \sqrt{F_{py}^2 - 3 \left(\frac{F'_i}{w' t_p} \right)^2}$ $a_i = 3.682 \left(\frac{t_p}{d_b} \right)^3 - 0.085$ $w' = b_p / 2 - (d_b + 1/16)$ $F'_i = \frac{t_p^2 F_{py} \left(0.85 \frac{b_p}{2} + 0.80 w' \right) + \frac{\pi d_b^3 F_t}{8}}{4 p_{f,i}}$
Outside Bolt Row Maximum Prying Force	$Q_{max,o} = \frac{w' t_p^2}{4 a_o} \sqrt{F_{py}^2 - 3 \left(\frac{F'_o}{w' t_p} \right)^2}$ $a_o = 3.682 \left(\frac{t_p}{d_b} \right)^3 - 0.085 \leq (p_{ext} - p_{f,o})$ $w' = b_p / 2 - (d_b + 1/16)$ $F'_o = \frac{t_p^2 F_{py} \left(0.85 \frac{b_p}{2} + 0.80 w' \right) + \frac{\pi d_b^3 F_t}{8}}{4 p_{f,o}}$

Table 4-2 Summary of Four-Bolt Extended Unstiffened Moment End-Plate Analysis

Geometry	Yield-Line Mechanism	Bolt Force Model
		
End-Plate Yield	$\phi M_n = \phi_b M_{pl} = \phi_b F_y F_p Y$ $Y = \frac{b_p}{2} \left[h_1 \left(\frac{1}{p_{f,i}} + \frac{1}{s} \right) + h_0 \left(\frac{1}{p_{f,o}} \right) - \frac{1}{2} \right] + \frac{2}{g} [h_1 (p_{f,i} + s)]$ $s = \frac{1}{2} \sqrt{b_p g} \quad \phi_b = 0.90$ <p>Note: Use $p_{f,i} = s$, if $p_{f,i} > s$</p>	
Bolt Rupture w/Prying Action	$\phi M_n = \phi M_q = \max \left[\begin{aligned} &\phi [2(P_t - Q_{max,o})d_0 + 2(P_t - Q_{max,i})d_1] \\ &\phi [2(T_b - Q_{max,o})d_0 + 2(T_b - Q_{max,i})d_1] \\ &\phi [2(P_t - Q_{max,i})d_1 + 2(T_b - Q_{max,o})d_0] \\ &\phi [2(T_b - Q_{max,i})d_0 + 2(T_b - Q_{max,o})d_1] \end{aligned} \right]$ $\phi = 0.75$	
Bolt Rupture No Prying Action	$\phi M_n = \phi M_{np} = \phi [2(P_t)(d_0 + d_1)]$ $\phi = 0.75$	

Table 4-3 Summary of Four-Bolt Extended Stiffened Moment End-Plate Analysis

<p>Geometry</p> 	<p>Yield-Line Mechanism; Case 1 when $s < d_e$</p> 
<p>Bolt Force Model</p> 	<p>Yield-Line Mechanism; Case 2 when $s \geq d_e$</p> 

Table 4-3 Summary of Four-Bolt Extended Stiffened Moment End-Plate Analysis(Continued)

End-Plate Yield	Case 1 $s < d_e$	$\phi M_n = \phi_y M_{pl} = \phi_y F_{yp} f_p^2 Y$ $Y = \frac{b_p}{2} \left[h_1 \left(\frac{1}{p_{f,i}} + \frac{1}{s} \right) + h_0 \left(\frac{1}{s} + \frac{1}{p_{f,o}} \right) \right] + \frac{2}{g} \left[h_1 (p_{f,i} + s) + h_0 (s + p_{f,o}) \right]$ <p>Note: Use $p_{f,i} = s$, if $p_{f,i} > s$</p> $s = \frac{1}{2} \sqrt{b_p g} \quad \phi_b = 0.90$
	Case 2 $s \geq d_e$	$\phi M_n = \phi_b M_{pl} = \phi_b F_{yp} f_p^2 Y$ $Y = \frac{b_p}{2} \left[h_1 \left(\frac{1}{p_{f,i}} + \frac{1}{s} \right) + h_0 \left(\frac{1}{p_{f,o}} + \frac{1}{2s} \right) \right] + \frac{2}{g} \left[h_1 (p_{f,i} + s) + h_0 (d_e + p_{f,o}) \right]$ <p>Note: Use $p_{f,i} = s$, if $p_{f,i} > s$</p> $s = \frac{1}{2} \sqrt{b_p g} \quad \phi_b = 0.90$
Bolt Rupture w/Prying Action		$\phi M_n = \phi M_q = \frac{\phi \left[2(P_t - Q_{max,o})d_0 + 2(P_t - Q_{max,i})d_1 \right]}{\phi \left[2(P_t - Q_{max,o})d_0 + 2(T_b)(d_1) \right]}$ $\phi = 0.75$
Bolt Rupture No Prying Action		$\phi M_n = \phi M_{np} = \phi \left[2(P_t)(d_0 + d_1) \right]$ $\phi = 0.75$

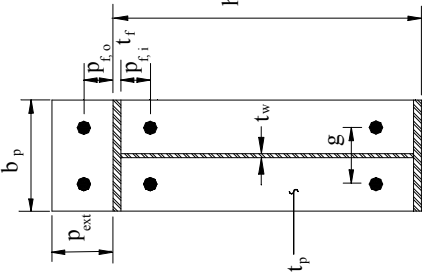
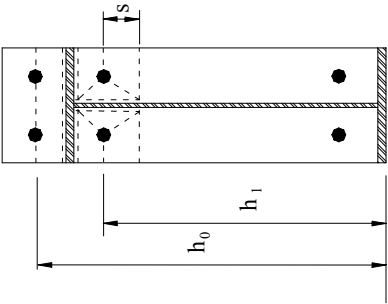
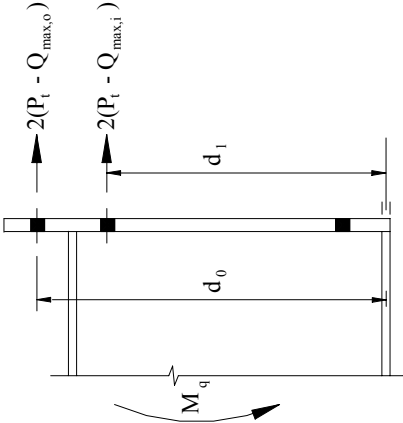
Table 4-4 Summary of Multiple Row Extended Unstiffened 1/2 Moment End-Plate Analysis

Geometry	Yield-Line Mechanism	Bolt Force Model
		
<p>End-Plate Yield</p>	$\phi M_n = \phi_b M_{pl} = \phi_b F_y p_p^2 Y$ $Y = \frac{b_p}{2} \left[\frac{1}{p_{f,i}} + h_2 \left(\frac{1}{s} \right) + h_0 \left(\frac{1}{p_{f,o}} \right) - \frac{1}{2} \right] + \frac{2}{g} \left[h_1 (p_{f,i} + 0.75 p_b) + h_2 (s + 0.25 p_b) \right] + \frac{g}{2}$ <p>$s = \frac{1}{2} \sqrt{b_p g}$ $\phi_b = 0.90$ Note: Use $p_{f,i} = s$, if $p_{f,i} > s$</p>	
<p>Bolt Rupture w/Prying Action</p>	$\phi M_n = \phi M_q = \max \left[\begin{aligned} &\phi \left[2(P_t - Q_{max,o})d_0 + 2(P_t - Q_{max,i})d_1 + 2(T_b)d_2 \right] \\ &\phi \left[2(P_t - Q_{max,o})d_0 + 2(T_b)(d_1 + d_2) \right] \\ &\phi \left[2(P_t - Q_{max,i})d_1 + 2(T_b)(d_0 + d_2) \right] \\ &\phi \left[2(T_b)(d_0 + d_1 + d_2) \right] \end{aligned} \right]$ <p>$\phi = 0.75$</p>	
<p>Bolt Rupture No Prying Action</p>	$\phi M_n = \phi M_{np} = \phi \left[2(P_t)(d_0 + d_1 + d_2) \right]$ <p>$\phi = 0.75$</p>	

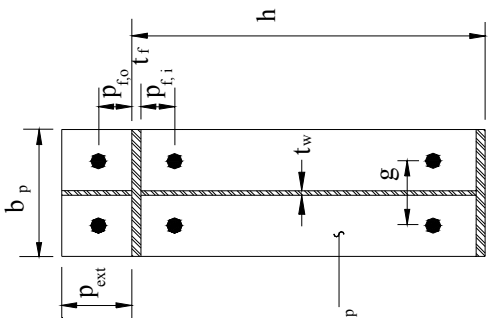
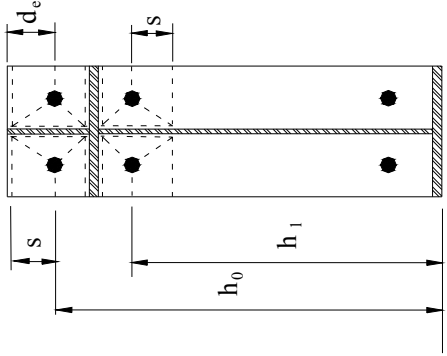
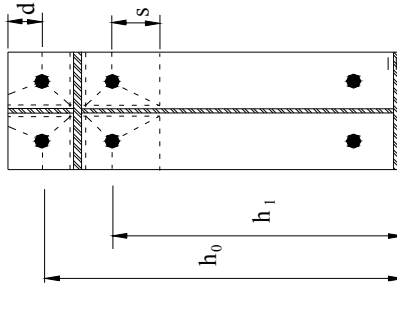
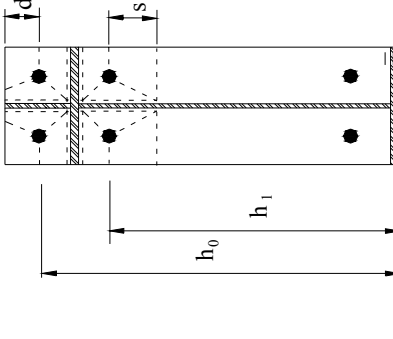
Table 4-5 Summary of Multiple Row Extended Unstiffened 1/3 Moment End-Plate Analysis

Geometry	Yield-Line Mechanism	Bolt Force Model
<p>End-Plate Yield</p>	$\phi M_n = \phi_b M_{pl} = \phi_b F_{py} p Y$ $Y = \frac{b_p}{2} \left[h_1 \left(\frac{1}{p_{f,i}} \right) + h_3 \left(\frac{1}{s} \right) + h_0 \left(\frac{1}{p_{f,o}} \right) - \frac{1}{2} \right] + \frac{2}{g} \left[h_1 (p_{f,i} + 1.5 p_b) + h_3 (s + 0.5 p_b) \right] + \frac{g}{2}$ $s = \frac{1}{2} \sqrt{b_p g} \quad \phi_b = 0.90 \quad \text{Note: Use } p_{f,i} = s, \text{ if } p_{f,i} > s$	
<p>Bolt Rupture w/Prying Action</p>	$\phi M_n = \phi M_q = \frac{\phi \left[2(P_t - Q_{max,o})d_0 + 2(P_t - Q_{max,i})(d_1 + d_3) + 2(T_b)d_2 \right]}{\max \left[2(P_t - Q_{max,o})d_0 + 2(T_b)(d_1 + d_2 + d_3) \right]}$ $\phi \left[2(P_t - Q_{max,i})(d_1 + d_3) + 2(T_b)(d_0 + d_2) \right]$ $\phi \left[2(T_b)(d_0 + d_1 + d_2 + d_3) \right]$ $\phi = 0.75$	
<p>Bolt Rupture No Prying Action</p>	$\phi M_n = \phi M_{np} = \phi \left[2(P_t)(d_0 + d_1 + d_2 + d_3) \right]$ $\phi = 0.75$	

Table 4-6 Summary of Multiple Row Extended Stiffened 1/3 Moment End-Plate Analysis

Geometry	Yield-Line Mechanism; Case 1 when $s < d_e$
<p>Bolt Force Model</p> 	
	

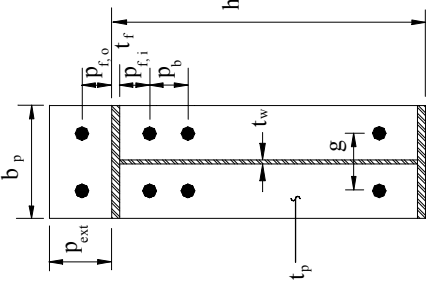
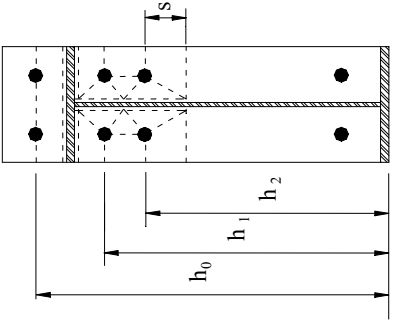
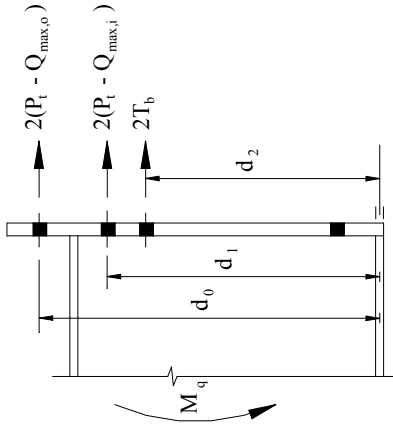
Table 4-6 Summary of Multiple Row Extended Stiffened 1/3 Moment End-Plate Analysis (Continued)

End-Plate Yield	Case 1 $s < d_e$	$\phi M_n = \phi_y M_{pl} = \phi_y F_{yp} Y$ $Y = \frac{b_p}{2} \left[h_l \left(\frac{1}{p_{f,i}} \right) + h_3 \left(\frac{1}{s} \right) + h_0 \left(\frac{1}{s} + \frac{1}{p_{f,o}} \right) \right] + \frac{2}{g} [h_l(p_{f,i} + 1.5p_b) + h_3(s + 0.5p_b) + h_0(s + p_{f,o})] + \frac{g}{2}$ $s = \frac{1}{2} \sqrt{b_p g} \quad \phi_b = 0.90 \quad \text{Note: Use } p_{f,i} = s, \text{ if } p_{f,i} > s$
	Case 2 $s \geq d_e$	$\phi M_n = \phi_b M_{pl} = \phi_b F_{yp} Y$ $Y = \frac{b_p}{2} \left[h_l \left(\frac{1}{p_{f,i}} \right) + h_3 \left(\frac{1}{s} \right) + h_0 \left(\frac{1}{p_{f,o}} + \frac{1}{2s} \right) \right] + \frac{2}{g} [h_l(p_{f,i} + 1.5p_b) + h_3(s + 0.5p_b) + h_0(d_e + p_{f,o})] + \frac{g}{2}$ $s = \frac{1}{2} \sqrt{b_p g} \quad \phi_b = 0.90 \quad \text{Note: Use } p_{f,i} = s, \text{ if } p_{f,i} > s$
Bolt Rupture w/Prying Action		$\phi M_n = \phi M_q = \begin{cases} \phi [2(P_t - Q_{max,o})d_0 + 2(P_t - Q_{max,i})(d_1 + d_3) + 2(T_b)d_2] \\ \phi [2(P_t - Q_{max,o})d_0 + 2(T_b)(d_1 + d_2 + d_3)] \\ \phi [2(P_t - Q_{max,i})(d_1 + d_3) + 2(T_b)(d_0 + d_2)] \\ \phi [2(T_b)(d_0 + d_1 + d_2 + d_3)] \end{cases}$ $\phi = 0.75$
	Bolt Rupture No Prying Action	$\phi M_n = \phi M_{np} = \phi [2(P_t)(d_0 + d_1 + d_2 + d_3)]$ $\phi = 0.75$

Table 4-7 Tested Parameter Range for Extended End-Plate Connections

Parameter	Low (in.)	High (in.)
p_f	1	$2 \frac{1}{2}^{(a)}$
p_{ext}	$2 \frac{1}{2}$	$5 \frac{1}{8}$
g	$2 \frac{3}{4}$	7
h	$15 \frac{3}{4}$	$24^{(b)}$
b_p	6	$10 \frac{1}{4}$
t_f	$\frac{3}{8}$	1

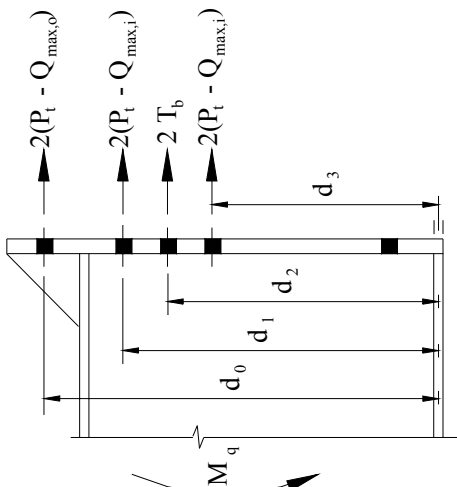
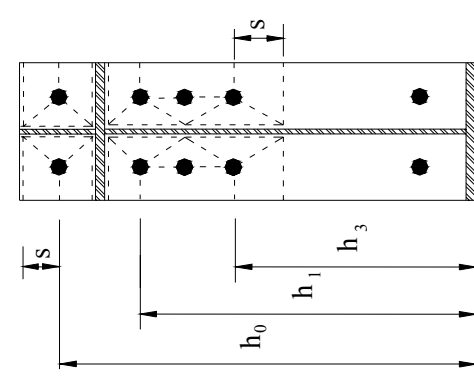
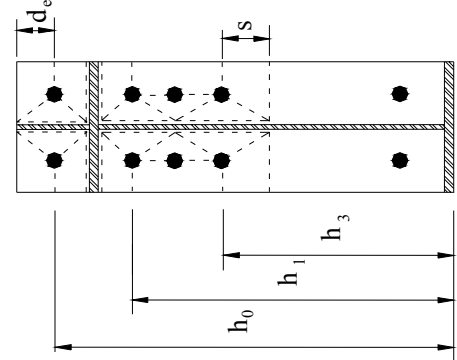
^aA large inner pitch, $p_{f,i}$, of 5 in. for the multiple row extended unstiffened 1/2 connection was also verified as reported in Sumner and Murray (2001).

^bFor the multiple row extended connections, the upper limit for depth is 62 in.

4.2 Design Examples

The following design examples are in the LRFD format. The same procedures apply for ASD design if the ASD moments are first converted to factored moments as explained in Section 2.5.2.

4.2.1 Four-Bolt Extended Unstiffened Moment End-Plate Connection (Table 4-2)

The required end-plate thickness and bolt diameter for an end-plate connection with the geometry shown below and a required factored moment of 1,750 k-in is to be determined. The end-plate material is A572 Gr 50, the bolts are snug-tightened A325, and the connection is used in rigid

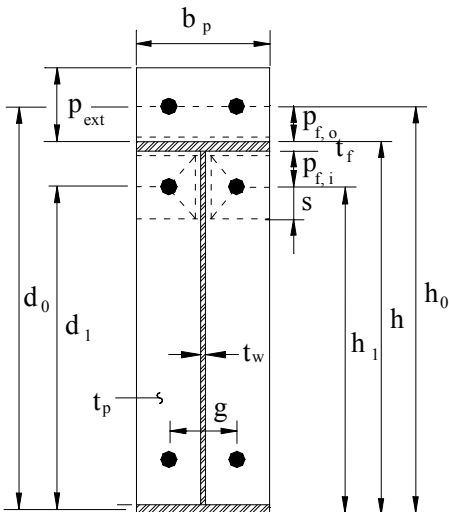

frame construction as assumed in the frame analysis. Both LRFD design procedures are illustrated.

Geometric Design Data

$$b_p = b_f = 8 \text{ in.}$$

$$t_f = 3/8 \text{ in.}$$

$$g = 3 \text{ in.}$$

$$p_{f,i} = 1 \frac{3}{4} \text{ in.}$$

$$p_{f,o} = 2 \frac{1}{2} \text{ in.}$$

$$p_{ext} = 5 \text{ in.}$$

$$h = 24 \text{ in.}$$

Calculate:

$$\gamma_r = 1.0 \text{ for extended connections}$$

$$d_0 = 24 + 2.5 - (0.375/2) = 26.3125 \text{ in.}$$

$$h_0 = 26.5 \text{ in.}$$

$$d_1 = 24 - 0.375 - 1.75 - (0.375/2) = 21.6875 \text{ in.}$$

$$h_1 = 21.875 \text{ in.}$$

Design Procedure 1 (Thick End-Plate and Smaller Diameter Bolts):

1.) Solve for the required bolt diameter assuming no prying action,

$$d_{b,reqd} = \sqrt{\frac{2M_u}{\pi\phi F_t (\sum d_n)}} = \sqrt{\frac{2(1750)}{\pi(0.75)(90)(26.313 + 21.688)}} = 0.59 \text{ in.}$$

Use $d_b = 5/8 \text{ in.}$

2.) Solve for the required end-plate thickness, $t_{p,reqd}$,

$$s = \frac{1}{2} \sqrt{b_p g} = \frac{1}{2} \sqrt{8.0(3.0)} = 2.45 \text{ in.}$$

$$p_{f,i} = 1.75 \text{ in.} \leq s \therefore \text{use } p_{f,i} = 1.75 \text{ in.}$$

$$Y = \frac{b_p}{2} \left[h_f \left(\frac{1}{p_{f,i}} + \frac{1}{s} \right) + h_o \left(\frac{1}{p_{f,o}} \right) - \frac{1}{2} \right] + \frac{2}{g} [h_f (p_{f,i} + s)]$$

$$= \frac{8.0}{2} \left[21.875 \left(\frac{1}{1.75} + \frac{1}{2.45} \right) + 26.5 \left(\frac{1}{2.5} \right) - \frac{1}{2} \right]$$

$$+ \frac{2}{3.0} [21.875(1.75 + 2.45)] = 187.4 \text{ in.}$$

$$P_t = \pi d_b^2 F_t / 4 = \pi (0.625)^2 (90) / 4 = 27.6 \text{ k}$$

$$\phi M_{np} = \phi [2P_t (\sum d_n)] = 0.75 [2(27.6)(26.313 + 21.688)] = 1987 \text{ k-in.}$$

$$t_{p,reqd} = \sqrt{\frac{1.11\gamma_r(\phi M_{np})}{\phi_b F_{py} Y}} = \sqrt{\frac{1.11(1.0)(1987)}{(0.90)(50)(187.4)}} = 0.51 \text{ in.}$$

Use $t_p = 9/16 \text{ in.}$

<p>Summary: $t_p = 9/16 \text{ in.}$ $d_b = 5/8 \text{ in.}$</p>

Design Procedure 2 (Thin End-Plate and Larger Diameter Bolts):

1.) Determine the required plate thickness,

$$t_{p,reqd} = \sqrt{\frac{\gamma_r M_u}{\phi_b F_{py} Y}} = \sqrt{\frac{1.0(1750)}{0.90(50)(187.4)}} = 0.46 \text{ in.}$$

Use $t_p = 1/2 \text{ in.}$

2.) Select a trial bolt diameter, d_b , and calculate the maximum prying forces, $Q_{max,i}$ and $Q_{max,o}$.

Try $d_b = 0.75 \text{ in.}$

$$w' = b_p / 2 - (d_b + 1/16) = (8.0 / 2) - (0.75 + 1/16) = 3.19 \text{ in.}$$

$$a_i = 3.682(t_p / d_b)^3 - 0.085 = 3.682(0.50 / 0.75)^3 - 0.085 = 1.01 \text{ in.}$$

$$F'_i = \frac{t_p^2 F_{py} \left[0.85 \left(\frac{b_p}{2} \right) + 0.80 w' \right] + \frac{\pi d_b^3 F_t}{8}}{4 p_{f,i}}$$

$$= \frac{0.50^2 (50) \left[0.85 \left(\frac{8.0}{2} \right) + 0.80(3.19) \right] + \frac{\pi(0.75)^3 90}{8}}{4(1.75)}$$

$$= 12.8 \text{ k}$$

$$Q_{max,i} = \frac{w' t_p^2}{4 a_i} \sqrt{F_{py}^2 - 3 \left(\frac{F'_i}{w' t_p} \right)^2}$$

$$= \frac{3.19(0.50)^2}{4(1.01)} \sqrt{(50)^2 - 3 \left(\frac{12.8}{3.19(0.50)} \right)^2}$$

$$= 9.48 \text{ k}$$

and for the outer bolts,

$$a_o = \min. \text{ of } 1.01 \text{ in. or } (p_{ext} - p_{f,o}) = 5 - 2.5 = 2.5 \text{ in.}$$

$$\therefore a_o = 1.01 \text{ in.}$$

$$F'_o = F'_i (p_{f,i} / p_{f,o}) = 12.8(1.75 / 2.5) = 8.75 \text{ k}$$

$$Q_{max,o} = \frac{w' t_p^2}{4 a_o} \sqrt{F_{py}^2 - 3 \left(\frac{F'_o}{w' t_p} \right)^2}$$

$$= \frac{3.19(0.50)^2}{4(1.01)} \sqrt{(50)^2 - 3 \left(\frac{8.75}{3.19(0.50)} \right)^2}$$

$$= 9.69 \text{ k}$$

3.) Calculate the connection design strength for the limit state of bolt rupture with prying action,

$$P_t = \pi d_b^2 F_t / 4 = \pi(0.75)^2 (90) / 4 = 39.8 \text{ k}$$

$$\phi M_q = \max \begin{cases} \phi [2(P_t - Q_{max,o})d_o + 2(P_t - Q_{max,i})d_l] \\ \phi [2(P_t - Q_{max,o})d_o + 2(T_b)(d_l)] \\ \phi [2(P_t - Q_{max,i})d_l + 2(T_b)(d_o)] \\ \phi [2(T_b)(d_o + d_l)] \end{cases}$$

For snug-tight bolts, T_b is 50% of Table J3.1 value = $0.50(28) = 14 \text{ k}$

$$\phi M_q = \begin{cases} 0.75 [2(39.8 - 9.69)26.313 + 2(39.8 - 9.48)(21.688)] = 2175 \text{ k-in.} \\ 0.75 [2(39.8 - 9.69)26.313 + 2(14)(21.688)] = 1644 \text{ k-in.} \\ 0.75 [2(39.8 - 9.48)(21.688) + 2(14)(26.313)] = 1539 \text{ k-in.} \\ 0.75 [2(14)(26.313 + 21.688)] = 1008 \text{ k-in.} \end{cases}$$

4.) Check that $\phi M_q > M_u$. If necessary, adjust the bolt diameter until ϕM_q is greater than M_u .

$\phi M_q = 2175 > 1750 \text{ k-in.}$, so the trial bolt, 3/4 in dia. is ok.

Note: A check (not shown) of 5/8 in. bolt confirms that 3/4 in. is required.

<p>Summary: $t_p = 1/2 \text{ in.}$ $d_b = 3/4 \text{ in.}$</p>
--

Comparison of Results for the Two Design Procedures

Design Procedure 1

End-Plate: A572 Gr 50 material
 $t_p = 9/16$ in.

Bolts: A325
 $d_b = 5/8$ in.

Design Procedure 2

End-Plate: A572 Gr 50 material
 $t_p = 1/2$ in.

Bolts: A325
 $d_b = 3/4$ in.

As expected, Design Procedure 1 results in a thicker end-plate and smaller diameter bolts than Design Procedure 2. Either design is acceptable. Note: A check of the design strength of the two designs using the procedure outlined in Appendix B yields the following:

Design Procedure 1: $\phi M_n = 1987$ k-in. (Thick plate behavior controlled by bolt rupture – no prying action)

Design Procedure 2: $\phi M_n = 2108$ k-in. (Thin plate behavior controlled by end-plate yielding)

4.2.2 Four-Bolt Extended Stiffened Moment End-Plate Connection (Table 4-3)

In this four-bolt stiffened example, the required factored moment of 1,750 k-in. and connection geometry of the four-bolt extended unstiffened connection of Example 4.2.1 is used so that the required end-plate thickness and bolt diameter can be compared. As before, the end-plate material is A572 Gr 50, the bolts are snug-tightened

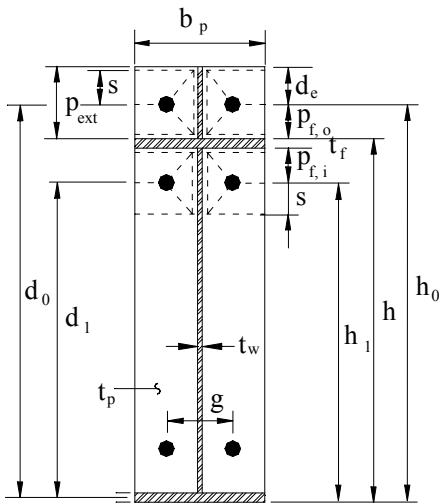

A325, and the connection is used in rigid frame construction as assumed in the frame analysis. Both LRFD design procedures are illustrated.

Geometric Design Data

$b_p = b_f = 8$ in.
 $t_f = 3/8$ in.
 $g = 3$ in.
 $p_{f,i} = 1\ 3/4$ in.
 $p_{f,o} = 2\ 1/2$ in.
 $p_{ext} = 5$ in.
 $h = 24$ in.

Calculate:

$\gamma_e = 1.0$ for extended connections
 $d_0 = 24 + 2.5 - (0.375/2) = 26.3125$ in.
 $h_0 = 26.5$ in.
 $d_1 = 24 - 0.375 - 1.75 - (0.375/2) = 21.6875$ in.
 $h_1 = 21.875$ in.
 $d_e = 5 - 2.5 = 2.5$ in.

Design Procedure 1 (Thick End-Plate and Smaller Diameter Bolts):

1.) Solve for the required bolt diameter assuming no prying action,

$$d_{b,reqd} = \sqrt{\frac{2M_u}{\pi\phi F_t(\sum d_n)}} = \sqrt{\frac{2(1750)}{\pi(0.75)(90)(26.313 + 21.688)}} = 0.59 \text{ in.}$$

Use $d_b = 5/8$ in.

2.) Solve for the required end-plate thickness, $t_{p,reqd}$,

$$s = \frac{1}{2}\sqrt{b_p g} = \frac{1}{2}\sqrt{8.0(3.0)} = 2.45 \text{ in.} < d_e$$

\therefore Case 1 governs

$p_{f,i} = 1.75$ in. $\leq s$ \therefore use $p_{f,i} = 1.75$ in.

$$Y = \frac{b_p}{2} \left[h_1 \left(\frac{1}{p_{f,i}} + \frac{1}{s} \right) + h_0 \left(\frac{1}{s} + \frac{1}{p_{f,o}} \right) \right] + \frac{2}{g} [h_1(p_{f,i} + s) + h_0(s + p_{f,o})]$$

$$= \frac{8.0}{2} \left[21.875 \left(\frac{1}{1.75} + \frac{1}{2.45} \right) + 26.5 \left(\frac{1}{2.45} + \frac{1}{2.5} \right) \right] + \frac{2}{3.0} [21.875(1.75 + 2.45) + 26.5(2.45 + 2.5)]$$

$$= 320.1 \text{ in.}$$

$$P_t = \pi d_b^2 F_t / 4 = \pi(0.625)^2(90) / 4 = 27.6 \text{ k}$$

$$\phi M_{np} = \phi [2P_t(\sum d_n)] = 0.75[2(27.6)(26.313 + 21.688)] \\ = 1987 \text{ k-in.}$$

$$t_{p,reqd} = \sqrt{\frac{1.11\gamma_r(\phi M_{np})}{\phi_b F_{py} Y}} = \sqrt{\frac{1.11(1.0)(1987)}{(0.90)(50)(320.1)}} \\ = 0.39 \text{ in.}$$

Use $t_p = 7/16$ in.

Summary:	$t_p = 7/16$ in. $d_b = 5/8$ in.
----------	-------------------------------------

Design Procedure 2 (Thin End-Plate and Larger Diameter Bolts):

1.) Determine the required plate thickness,

$$t_{p,reqd} = \sqrt{\frac{\gamma_r M_u}{\phi_b F_{py} Y}} = \sqrt{\frac{1.0(1750)}{0.90(50)(320.1)}} = 0.35 \text{ in.}$$

Use $t_p = 3/8$ in.

2.) Select a trial bolt diameter, d_b , and calculate the maximum prying forces, $Q_{max,i}$ and $Q_{max,o}$

Try $d_b = 0.75$ in.

$$w' = b_p / 2 - (d_b + 1/16) = (8.0 / 2) - (0.75 + 1/16) \\ = 3.19 \text{ in.}$$

$$a_i = 3.682(t_p / d_b)^3 - 0.085 \\ = 3.682(0.375 / 0.75)^3 - 0.085 = 0.38 \text{ in.}$$

$$F'_i = \frac{t_p^2 F_{py} \left[0.85 \left(\frac{b_p}{2} \right) + 0.80w' \right] + \frac{\pi d_b^3 F_t}{8}}{4p_{f,i}} \\ = \frac{0.375^2 (50) \left[0.85 \left(\frac{8.0}{2} \right) + 0.80(3.19) \right] + \frac{\pi (0.75)^3 90}{8}}{4(1.75)} \\ = 8.11 \text{ k}$$

$$Q_{max,i} = \frac{w't_p^2}{4a_i} \sqrt{F_{py}^2 - 3 \left(\frac{F'_i}{w't_p} \right)^2} \\ = \frac{3.19(0.375)^2}{4(0.38)} \sqrt{(50)^2 - 3 \left(\frac{8.11}{3.19(0.375)} \right)^2} \\ = 14.3 \text{ k}$$

and for the outer bolts,

$$a_o = \min \text{ of } 0.38 \text{ in. or } (p_{ext} - p_{f,o}) = 5 - 2.5 = 2.5 \text{ in.} \\ \therefore a_o = 0.38 \text{ in.}$$

$$F'_o = F'_i(p_{f,i} / p_{f,o}) = 8.11(1.75 / 2.5) = 5.68 \text{ k}$$

$$Q_{max,o} = \frac{w't_p^2}{4a_o} \sqrt{F_{py}^2 - 3 \left(\frac{F'_o}{w't_p} \right)^2} \\ = \frac{3.19(0.375)^2}{4(0.38)} \sqrt{(50)^2 - 3 \left(\frac{5.68}{3.19(0.375)} \right)^2} \\ = 14.6 \text{ k}$$

3.) Calculate the connection design strength for the limit state of bolt rupture with prying action,

$$P_t = \pi d_b^2 F_t / 4 = \pi (0.75)^2 (90) / 4 = 39.8 \text{ k}$$

$$\phi M_q = \max \begin{cases} \phi [2(P_t - Q_{max,o})d_0 + 2(P_t - Q_{max,i})d_1] \\ \phi [2(P_t - Q_{max,o})d_0 + 2(T_b)(d_1)] \\ \phi [2(P_t - Q_{max,i})d_1 + 2(T_b)(d_0)] \\ \phi [2(T_b)(d_0 + d_1)] \end{cases}$$

For snug-tight bolts, T_b is 50% of Table J3.1 value
= 0.50(28) = 14 k

$$\phi M_q = \begin{cases} 0.75[2(39.8 - 14.6)26.313 \\ \quad + 2(39.8 - 14.3)(21.688)] = 1824 \text{ k-in.} \\ 0.75[2(39.8 - 14.6)26.313 + 2(14)(21.688)] \\ \quad = 1450 \text{ k-in.} \\ 0.75[2(39.8 - 14.3)(21.688) + 2(14)(26.313)] \\ \quad = 1382 \text{ k-in.} \\ \max \quad 0.75[2(14)(26.313 + 21.688)] = 1008 \text{ k-in.} \end{cases}$$

4.) Check that $\phi M_q > M_u$. If necessary, adjust the bolt diameter until ϕM_q is greater than M_u .

$\phi M_q = 1824 > 1750$ k-in., so the trial bolt,
3/4 in. dia. is ok.

Summary:	$t_p = 3/8$ in. $d_b = 3/4$ in.
----------	------------------------------------

Comparison of Results for the Two Design Procedures

Design Procedure 1

End-Plate: A572 Gr 50 material
 $t_p = 7/16$ in.
 Bolts: A325
 $d_b = 5/8$ in.

Design Procedure 2

End-Plate: A572 Gr 50 material
 $t_p = 3/8$ in.
 Bolts: A325
 $d_b = 3/4$ in.

As expected, Design Procedure 1 results in a thicker end-plate and smaller diameter bolts than Design Procedure 2. Either design is acceptable. Note: A check of the design strength of the two designs using the procedure outlined in Appendix B yields the following:

Design Procedure 1: $\phi M_n = 1987$ k-in. (Thick plate behavior controlled by bolt rupture – no prying action)

Design Procedure 2: $\phi M_n = 1824$ k-in. (Thin plate behavior controlled by bolt rupture with prying action)

A comparison of Examples 4.2.1 and 4.2.2 shows that the addition of the stiffener reduces the end-plate thickness by 1/8 inch for both design procedures. The bolt size is unaffected.

4.2.3 Multiple Row Extended Unstiffened 1/2 Moment End-Plate Connection (Table 4-4)

The required end-plate thickness and bolt diameter for an end-plate connection with the geometry shown below are to be determined for a required factored moment of 2,200 k-in. and a factored axial tension of 16.9 kips. The end-

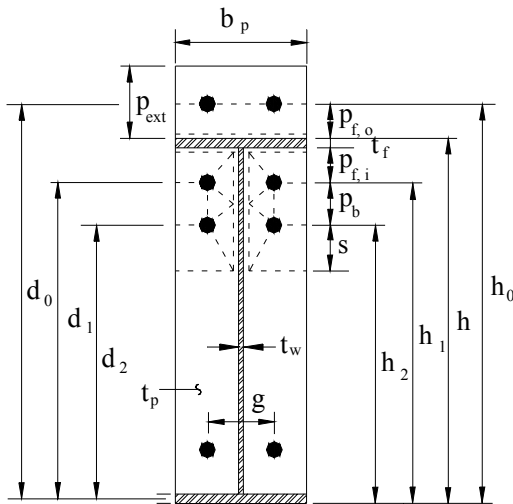

plate material is A572 Gr 50, the bolts are fully tightened A325, and the connection is used in rigid frame construction as assumed in the frame analysis. Both LRFD design procedures are illustrated.

Geometric Design Data

$b_p = b_f = 8$ in
 $t_f = 3/8$ in
 $g = 3$ in
 $p_{f,i} = 1\ 3/4$ in
 $p_{f,o} = 2\ 1/2$ in
 $p_b = 2\ 1/2$ in
 $p_{ext} = 5$ in
 $h = 24$ in

Calculate:

$\gamma_r = 1.0$ for extended connections
 $d_0 = 24 + 2.5 - (0.375/2) = 26.3125$ in.
 $h_0 = 26.5$ in.
 $d_1 = 24 - 0.375 - 1.75 - (0.375/2) = 21.6875$ in.
 $h_1 = 21.875$ in.
 $d_2 = 24 - 0.375 - 1.75 - 2.5 - (0.375/2) = 19.1875$ in.
 $h_2 = 19.375$

Axial Load Treatment

The procedure is to convert the factored axial load into an equivalent moment that will be added to the factored connection moment for axial tension, or subtracted from the factored connection moment for axial compression. For this example the axial load is tension and will add to the flange force at the tension flange. The connection moment is increased.

$T_u = 16.9$ kips
 $h - t_f = 24 - 0.375 = 23.625$ in.
 $M_{axial} = (16.9/2)(23.625) = 200$ k-in.

Total factored moment, $M_u = 2200 + 200 = 2400$ k-in.

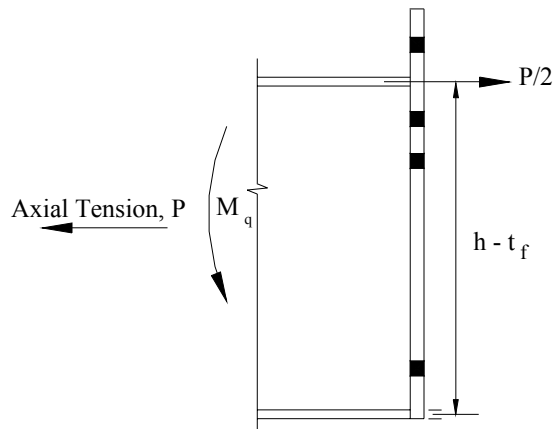

Design Procedure 1 (Thick End-Plate and Smaller Diameter Bolts):

1.) Solve for the required bolt diameter assuming no prying action,

$$d_{b,reqd} = \sqrt{\frac{2M_u}{\pi\phi F_t(\sum d_n)}} = \sqrt{\frac{2(2400)}{\pi(0.75)(90)(26.313 + 21.688 + 19.188)}} = 0.58 \text{ in.}$$

Use $d_b = 5/8$ in.

2.) Solve for the required end-plate thickness, $t_{p,reqd}$,

$$s = \frac{1}{2}\sqrt{b_p g} = \frac{1}{2}\sqrt{8.0(3.0)} = 2.45 \text{ in.}$$

$$p_{f,i} = 1.75 \text{ in} \leq s \therefore \text{use } p_{f,i} = 1.75 \text{ in.}$$

$$Y = \frac{b_p}{2} \left[\left(\frac{h_l}{p_{f,i}} \right) + \left(\frac{h_2}{s} \right) + \left(\frac{h_o}{p_{f,o}} \right) - \frac{1}{2} \right] + \frac{2}{g} [h_l(p_{f,i} + 0.75p_b) + h_2(s + 0.25p_b)] + \frac{g}{2} = \frac{8.0}{2} \left[\left(\frac{21.875}{1.75} \right) + \left(\frac{19.375}{2.45} \right) + \left(\frac{26.5}{2.5} \right) - \frac{1}{2} \right] + \frac{2}{3.0} [21.875(1.75 + 0.75(2.5)) + 19.375(2.45 + 0.25(2.5))] + \frac{3.0}{2} = 216.1 \text{ in.}$$

$$P_t = \pi d_b^2 F_t / 4 = \pi(0.625)^2(90) / 4 = 27.6 \text{ k}$$

$$\phi M_{np} = \phi [2P_t(\sum d_n)] = 0.75[2(27.6)(26.313 + 21.688 + 19.188)] = 2782 \text{ k-in.}$$

$$t_{p,reqd} = \sqrt{\frac{1.11\gamma_r(\phi M_{np})}{\phi_b F_{py} Y}} = \sqrt{\frac{1.11(1.0)(2782)}{(0.90)(50)(216.1)}} = 0.56 \text{ in.}$$

Use $t_p = 9/16$ in.

Summary:	$t_p = 9/16$ in. $d_b = 5/8$ in.
-----------------	-------------------------------------

Design Procedure 2 (Thin End-Plate and Larger Diameter Bolts):

1.) Determine the required plate thickness,

$$t_{p,reqd} = \sqrt{\frac{\gamma_r M_u}{\phi_b F_{py} Y}} = \sqrt{\frac{1.0(2400)}{0.90(50)(216.1)}} = 0.50 \text{ in.}$$

Use $t_p = 1/2$ in.

2.) Select a trial bolt diameter, d_b , and calculate the maximum prying forces, $Q_{max,i}$ and $Q_{max,o}$.

Try $d_b = 3/4$ in.

$$w' = b_p / 2 - (d_b + 1/16) = (8.0 / 2) - (0.75 + 1/16) = 3.19 \text{ in.}$$

$$a_i = 3.682(t_p / d_b)^3 - 0.085 = 3.682(0.50 / 0.75)^3 - 0.085 = 1.01 \text{ in.}$$

$$F'_i = \frac{t_p^2 F_{py} \left[0.85 \left(\frac{b_p}{2} \right) + 0.80w' \right] + \frac{\pi d_b^3 F_t}{8}}{4p_{f,i}} = \frac{0.50^2 (50) \left[0.85 \left(\frac{8.0}{2} \right) + 0.80(3.19) \right] + \frac{\pi(0.75)^3 90}{8}}{4(1.75)} = 12.8 \text{ k}$$

$$Q_{max,i} = \frac{w' t_p^2}{4a_i} \sqrt{F_{py}^2 - 3 \left(\frac{F'_i}{w' t_p} \right)^2} = \frac{3.19(0.50)^2}{4(1.01)} \sqrt{(50)^2 - 3 \left(\frac{12.8}{3.19(0.50)} \right)^2} = 9.48 \text{ k}$$

and for the outer bolts,

$$a_o = \min \text{ of } 1.01 \text{ in. or } (p_{ext} - p_{f,o}) = 5 - 2.5 = 2.5 \text{ in.} \therefore a_o = 1.01 \text{ in.}$$

$$F'_o = F'_i(p_{f,i} / p_{f,o}) = 12.8(1.75 / 2.5) = 8.96 \text{ k}$$

$$Q_{max,o} = \frac{w' t_p^2}{4a_o} \sqrt{F_{py}^2 - 3 \left(\frac{F'_o}{w' t_p} \right)^2}$$

$$= \frac{3.19(0.50)^2}{4(1.01)} \sqrt{(50)^2 - 3 \left(\frac{8.96}{3.19(0.50)} \right)^2}$$

$$= 9.68 \text{ k}$$

- 3.) Calculate the connection design strength for the limit state of bolt rupture with prying action,

$$P_t = \pi d_b^2 F_t / 4 = \pi (0.75)^2 90 / 4 = 39.8 \text{ k}$$

$$\phi M_q = \max \begin{cases} \phi [2(P_t - Q_{max,o})d_0 + 2(P_t - Q_{max,i})d_1 + 2(T_b)d_2] \\ \phi [2(P_t - Q_{max,o})d_0 + 2(T_b)(d_1 + d_2)] \\ \phi [2(P_t - Q_{max,i})d_1 + 2(T_b)(d_0 + d_2)] \\ \phi [2(T_b)(d_0 + d_1 + d_2)] \end{cases}$$

$$T_b \approx 0.7P_t = 0.7(39.8) = 27.9 \text{ k}, \text{ or from Table J3.1,}$$

Use $T_b = 28 \text{ k}$

$$\phi M_q = \max \begin{cases} 0.75[2(39.8 - 9.68)26.313 + 2(39.8 - 9.48)(21.688) + 2(28)19.188] = 2981 \text{ k-in.} \\ 0.75[2(39.8 - 9.68)26.313 + 2(28)(21.688 + 19.188)] = 2906 \text{ k-in.} \\ 0.75[2(39.8 - 9.48)(21.688) + 2(28)(26.313 + 19.188)] = 2897 \text{ k-in.} \\ 0.75[2(28)(26.313 + 21.688 + 19.188)] = 2822 \text{ k-in.} \end{cases}$$

- 4.) Check that $\phi M_q > M_u$. If necessary, adjust the bolt diameter until ϕM_q is greater than M_u .

$$\phi M_q = 2981 > 2500 \text{ k-in.}, \text{ so the trial bolt,}$$

3/4 in. dia. is ok.

<u>Summary:</u>	$t_p = 1/2 \text{ in.}$
	$d_b = 3/4 \text{ in.}$

Comparison of Results for the Two Design Procedures:

Design Procedure 1

End-Plate: A572 Gr 50 material

$$t_p = 9/16 \text{ in.}$$

Bolts: A325

$$d_b = 5/8 \text{ in.}$$

Design Procedure 2

End-Plate: A572 Gr 50 material

$$t_p = 1/2 \text{ in.}$$

Bolts: A325

$$d_b = 3/4 \text{ in.}$$

As expected, Design Procedure 1 results in a thicker end-plate and smaller diameter bolts than Design Procedure 2. Either design is acceptable. Note: A check of the design strength of the two designs using the procedure outlined in Appendix B yields the following:

Design Procedure 1: $\phi M_n = 2782 \text{ k-in.}$ (Thick plate behavior controlled by bolt rupture – no prying action)

Design Procedure 2: $\phi M_n = 2431 \text{ k-in.}$ (Thin plate behavior controlled by end-plate yielding)

4.2.4 Multiple Row Extended Unstiffened 1/3 Moment End-Plate Connection (Table 4-5)

The required end-plate thickness and bolt diameter for an end-plate connection with the geometry shown below and a required factored moment of 4,600 k-in. is to be determined. The end-plate material is A572 Gr 50, the bolts are fully tightened A325, and the connection is used in rigid frame construction as assumed in the frame analysis. Both LRFD design procedures are illustrated.

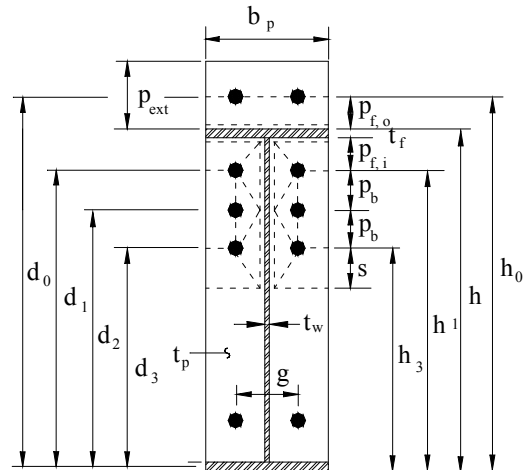

Geometric Design Data

$$b_p = b_f = 8 \text{ in.}$$

$$t_f = 3/8 \text{ in.}$$

$$g = 3 \text{ in.}$$

$$p_{f,i} = 1 \ 3/4 \text{ in.}$$

$$p_{f,o} = 2 \ 1/2 \text{ in.}$$

$$p_b = 2 \ 1/2 \text{ in.}$$

$$p_{ext} = 5 \text{ in.}$$

$$h = 36 \text{ in.}$$

Calculate:

$$\gamma_r = 1.0 \text{ for extended connections}$$

$$d_0 = 36 + 2.5 - (0.375/2) = 38.3125 \text{ in.}$$

$$h_0 = 38.5 \text{ in.}$$

$$d_1 = 36 - 0.375 - 1.75 - (0.375/2) = 33.6875 \text{ in.}$$

$$\begin{aligned}
h_1 &= 33.875 \text{ in.} \\
d_2 &= 36 - 0.375 - 1.75 - 2.5 - (0.375/2) = 31.1875 \text{ in.} \\
h_2 &= 31.375 \text{ in.} \\
d_3 &= 36 - 0.375 - 1.75 - 2.5 - 2.5 - (0.375/2) = 28.6875 \text{ in.} \\
h_3 &= 28.875 \text{ in.}
\end{aligned}$$

Design Procedure 1 (Thick End-Plate and Smaller Diameter Bolts):

- 1.) Solve for the required bolt diameter assuming no prying action,

$$\begin{aligned}
d_{b,reqd} &= \sqrt{\frac{2M_u}{\pi\phi F_t (\sum d_n)}} \\
&= \sqrt{\frac{2(4600)}{\pi(0.75)(90)(38.313 + 33.688 + 31.188 + 28.688)}} \\
&= 0.57 \text{ in.}
\end{aligned}$$

Use $d_b = 5/8$ in.

- 2.) Solve for the required end-plate thickness, $t_{p,reqd}$,

$$s = \frac{1}{2} \sqrt{b_p g} = \frac{1}{2} \sqrt{8.0(3.0)} = 2.45 \text{ in.}$$

$$p_{f,i} = 1.75 \text{ in} \leq s \therefore \text{use } p_{f,i} = 1.75 \text{ in.}$$

$$\begin{aligned}
Y &= \frac{b_p}{2} \left[h_1 \left(\frac{1}{p_{f,i}} \right) + h_3 \left(\frac{1}{s} \right) + h_0 \left(\frac{1}{p_{f,o}} \right) - \frac{1}{2} \right] \\
&\quad + \frac{2}{g} [h_1(p_{f,i} + 1.5p_b) + h_3(s + 0.5p_b)] + \frac{g}{2} \\
&= \frac{8.0}{2} \left[33.875 \left(\frac{1}{1.75} \right) + 28.6875 \left(\frac{1}{2.45} \right) \right. \\
&\quad \left. + 38.5 \left(\frac{1}{2.5} \right) - \frac{1}{2} \right] + \frac{2}{3.0} [33.875(1.75 + 1.5(2.5)) \\
&\quad + 28.6875(2.45 + 0.5(2.5))] + \frac{3.0}{2} = 380.3 \text{ in.}
\end{aligned}$$

$$P_t = \pi d_b^2 F_t / 4 = \pi(0.625)^2(90) / 4 = 27.6 \text{ k}$$

$$\begin{aligned}
\phi M_{np} &= \phi [2P_t (\sum d_n)] \\
&= 0.75 [2(27.6)(38.313 + 33.688 + 31.188 + 28.688)] \\
&= 5460 \text{ k-in.}
\end{aligned}$$

$$\begin{aligned}
t_{p,reqd} &= \sqrt{\frac{1.11\gamma_r(\phi M_{np})}{\phi_b F_{py} Y}} = \sqrt{\frac{1.11(1.0)(5460)}{(0.90)(50)(380.3)}} \\
&= 0.60 \text{ in.}
\end{aligned}$$

Use $t_p = 5/8$ in.

Summary:	$t_p = 5/8$ in. $d_b = 5/8$ in.
----------	------------------------------------

Design Procedure 2 (Thin End-Plate and Larger Diameter Bolts):

- 1.) Determine the required plate thickness,

$$t_{p,reqd} = \sqrt{\frac{\gamma_r M_u}{\phi_b F_{py} Y}} = \sqrt{\frac{1.0(4600)}{0.90(50)(380.3)}} = 0.52 \text{ in.}$$

Use $t_p = 9/16$ in.

- 2.) Select a trial bolt diameter, d_b , and calculate the maximum prying forces, $Q_{max,i}$ and $Q_{max,o}$.

Try $d_b = 3/4$ in.

$$\begin{aligned}
w' &= b_p / 2 - (d_b + 1/16) = (8.0 / 2) - (0.75 + 1/16) \\
&= 3.19 \text{ in.}
\end{aligned}$$

$$\begin{aligned}
a_i &= 3.682(t_p / d_b)^3 - 0.085 \\
&= 3.682(0.5625 / 0.75)^3 - 0.085 = 1.47 \text{ in.}
\end{aligned}$$

$$\begin{aligned}
F'_i &= \frac{t_p^2 F_{py} \left[0.85 \left(\frac{b_p}{2} \right) + 0.80 w' \right] + \frac{\pi d_b^3 F_t}{8}}{4 p_{f,i}} \\
&= \frac{0.5625^2 (50) \left[0.85 \left(\frac{8.0}{2} \right) + 0.80(3.19) \right] + \frac{\pi(0.75)^3 90}{8}}{4(1.75)} \\
&= 15.6 \text{ k}
\end{aligned}$$

$$\begin{aligned}
Q_{max,i} &= \frac{w' t_p^2}{4 a_i} \sqrt{F_{py}^2 - 3 \left(\frac{F'_i}{w' t_p} \right)^2} \\
&= \frac{3.19(0.5625)^2}{4(1.47)} \sqrt{(50)^2 - 3 \left(\frac{15.6}{3.19(0.5625)} \right)^2} \\
&= 8.18 \text{ k}
\end{aligned}$$

and for the outer bolts,

$$\begin{aligned}
a_o &= \min \text{ of } 1.47 \text{ in or } (p_{ext} - p_{f,o}) = 5 - 2.5 = 2.5 \text{ in.} \\
\therefore a_o &= 1.47 \text{ in.}
\end{aligned}$$

$$F'_o = F'_i(p_{f,i} / p_{f,o}) = 15.6(1.75 / 2.5) = 10.9 \text{ k}$$

$$Q_{max,o} = \frac{w't_p^2}{4a_o} \sqrt{F_{py}^2 - 3\left(\frac{F'_o}{w't_p}\right)^2}$$

$$= \frac{3.19(0.5625)^2}{4(1.47)} \sqrt{(50)^2 - 3\left(\frac{10.9}{3.19(0.5625)}\right)^2}$$

$$= 8.39 \text{ k}$$

- 3.) Calculate the connection design strength for the limit state of bolt rupture with prying action,

$$P_t = \pi d_b^2 F_t / 4 = \pi(0.75)^2 90 / 4 = 39.8 \text{ k}$$

$$\phi M_q = \max \left\{ \begin{array}{l} \phi \left[2(P_t - Q_{max,o})d_0 + 2(P_t - Q_{max,i})(d_1 + d_3) + 2(T_b)d_2 \right] \\ \phi \left[2(P_t - Q_{max,o})d_0 + 2(T_b)(d_1 + d_2 + d_3) \right] \\ \phi \left[2(P_t - Q_{max,i})(d_1 + d_3) + 2(T_b)(d_0 + d_2) \right] \\ \phi \left[2(T_b)(d_0 + d_1 + d_2 + d_3) \right] \end{array} \right.$$

$$T_b \approx 0.7P_t = 0.7(39.8) = 27.9 \text{ k}, \text{ or from Table J3.1,}$$

Use $T_b = 28 \text{ k}$

$$\phi M_q = \max \left\{ \begin{array}{l} 0.75[2(39.8 - 8.39)38.313 + 2(39.8 - 8.18)(33.688 + 28.688) + 2(28)31.188] = 6074 \text{ k-in.} \\ 0.75[2(39.8 - 8.39)38.313 + 2(28)(33.688 + 31.188 + 28.688)] = 5735 \text{ k-in.} \\ 0.75[2(39.8 - 8.18)(33.688 + 28.688) + 2(28)(38.313 + 31.188)] = 5878 \text{ k-in.} \\ 0.75[2(28)(38.313 + 33.688 + 31.188 + 28.688)] = 5539 \text{ k-in.} \end{array} \right.$$

- 4.) Check that $\phi M_q > M_u$. If necessary, adjust the bolt diameter until ϕM_q is greater than M_u .

$$\phi M_q = 6074 > 4600 \text{ k-in so the trial bolt,}$$

3/4 in dia. is ok.

Note: A check (not shown) of 5/8 in. bolt confirms that 3/4 in. is required.

Summary: $t_p = 9/16 \text{ in.}$
 $d_b = 3/4 \text{ in.}$

Comparison of Results for the Two Design Procedures

Design Procedure 1

End-Plate: A572 Gr 50 material

$$t_p = 5/8 \text{ in.}$$

Bolts: A325

$$d_b = 5/8 \text{ in.}$$

Design Procedure 2

End-Plate: A572 Gr 50 material

$$t_p = 9/16 \text{ in.}$$

Bolts: A325

$$d_b = 3/4 \text{ in.}$$

Rev.
3/1/03

As expected, Design Procedure 1 results in a thicker end-plate and smaller diameter bolts than Design Procedure 2. Either design is acceptable. Note: A check of the design strength of the two designs using the procedure outlined in Appendix B yields the following:

Design Procedure 1: $\phi M_n = 5460 \text{ k-in.}$ (Thick plate behavior controlled by bolt rupture – no prying action)

Design Procedure 2: $\phi M_n = 5415 \text{ k-in.}$ (Thin plate behavior controlled by end-plate yielding)

4.2.5 Multiple Row Extended Stiffened 1/3 Moment End-Plate Connection (Table 4-6)

The required end-plate thickness and bolt diameter for an end-plate connection with the geometry shown below and a required factored moment of 4,600 k-in. is to be determined. The end-plate material is A572 Gr 50 and the bolts are fully tightened A325, and the connection is used in rigid frame construction as assumed in the frame analysis. Both LRFD design procedures are illustrated.

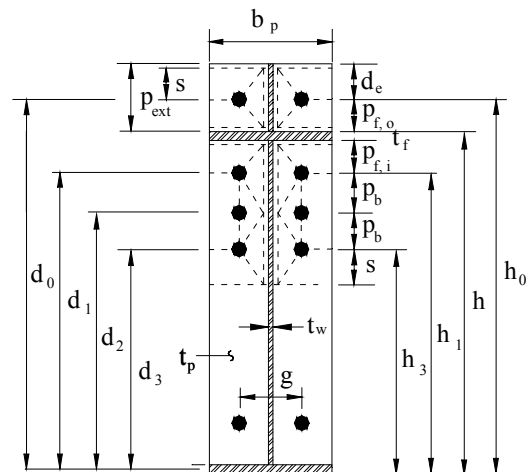

Geometric Design Data

$$b_p = b_f = 8 \text{ in.}$$

$$t_f = 3/8 \text{ in.}$$

$$g = 3 \text{ in.}$$

$$\begin{aligned}
p_{f,i} &= 1 \text{ 3/4 in.} \\
p_{f,o} &= 2 \text{ 1/2 in} \\
p_b &= 2 \text{ 1/2 in.} \\
p_{ext} &= 5 \text{ in.} \\
h &= 36 \text{ in.}
\end{aligned}$$

Calculate:

$$\begin{aligned}
\gamma_r &= 1.0 \text{ for extended connections} \\
d_0 &= 36+2.5-(0.375/2) = 38.3125 \text{ in.} \\
h_0 &= 38.5 \text{ in.} \\
d_1 &= 36-0.375-1.75-(0.375/2) = 33.6875 \text{ in.} \\
h_1 &= 33.875 \text{ in.} \\
d_2 &= 36-0.375-1.75-2.5-(0.375/2) = 31.1875 \text{ in.} \\
h_2 &= 31.375 \text{ in.} \\
d_3 &= 36-0.375-1.75-2.5-2.5-(0.375/2) = 28.6875 \text{ in.} \\
h_3 &= 28.875 \text{ in.} \\
d_e &= 5-2.5 = 2.5 \text{ in.}
\end{aligned}$$

Design Procedure 1 (Thick End-Plate and Smaller Diameter Bolts):

1.) Solve for the required bolt diameter assuming no prying action,

$$\begin{aligned}
d_{b,reqd} &= \sqrt{\frac{2M_u}{\pi\phi F_t (\sum d_n)}} \\
&= \sqrt{\frac{2(4600)}{\pi(0.75)(90)(38.313+33.688+31.188+28.688)}} \\
&= 0.57 \text{ in.}
\end{aligned}$$

Use $d_b = 5/8 \text{ in.}$

2.) Solve for the required end-plate thickness, $t_{p,reqd}$,

$$s = \frac{1}{2} \sqrt{b_p g} = \frac{1}{2} \sqrt{8.0(3.0)} = 2.45 \text{ in.} < d_e$$

∴ Case 1 governs.

$$p_{f,i} = 1.75 \text{ in} \leq s \therefore \text{use } p_{f,i} = 1.75 \text{ in.}$$

$$\begin{aligned}
Y &= \frac{b_p}{2} \left[h_1 \left(\frac{1}{p_{f,i}} \right) + h_3 \left(\frac{1}{s} \right) + h_0 \left(\frac{1}{s} + \frac{1}{p_{f,o}} \right) \right] \\
&\quad + \frac{2}{g} \left[h_1 (p_{f,i} + 1.5p_b) + h_3 (s + 0.5p_b) + h_0 (s + p_{f,o}) \right] + \frac{g}{2} \\
&= \frac{8.0}{2} \left[33.875 \left(\frac{1}{1.75} \right) + 28.875 \left(\frac{1}{2.45} \right) + 38.5 \left(\frac{1}{2.45} + \frac{1}{2.5} \right) \right]
\end{aligned}$$

$$\begin{aligned}
&+ \frac{2}{3.0} [33.875(1.75 + 1.5(2.5)) + 28.875(2.45 + 0.5(2.5))] \\
&+ 38.5(2.45 + 2.5) \Big] + \frac{3.0}{2} = 573.0 \text{ in.}
\end{aligned}$$

$$P_t = \pi d_b^2 F_t / 4 = \pi(0.625)^2 (90) / 4 = 27.6 \text{ k}$$

$$\begin{aligned}
\phi M_{np} &= \phi [2P_t (\sum d_n)] \\
&= 0.75 [2(27.6)(38.313 + 33.688 + 31.188 + 28.688)] \\
&= 5460 \text{ k-in.}
\end{aligned}$$

$$t_{p,reqd} = \sqrt{\frac{1.11\gamma_r (\phi M_{np})}{\phi_b F_{py} Y}} = \sqrt{\frac{1.11(1.0)(5460)}{(0.90)(50)(573)}} = 0.48 \text{ in.}$$

Use $t_p = 1/2 \text{ in.}$

Summary:	$t_p = 1/2 \text{ in.}$ $d_b = 5/8 \text{ in.}$
----------	--

Design Procedure 2 (Thin End-Plate and Larger Diameter Bolts):

1.) Determine the required plate thickness,

$$t_{p,reqd} = \sqrt{\frac{\gamma_r M_u}{\phi_b F_{py} Y}} = \sqrt{\frac{1.0(4600)}{0.90(50)(573)}} = 0.42 \text{ in.}$$

Use $t_p = 7/16 \text{ in.}$

2.) Select a trial bolt diameter, d_b , and calculate the maximum prying forces, $Q_{max,i}$ and $Q_{max,o}$.

Try $d_b = 3/4 \text{ in.}$

$$\begin{aligned}
w' &= b_p / 2 - (d_b + 1/16) = (8.0/2) - (0.75 + 1/16) \\
&= 3.19 \text{ in.}
\end{aligned}$$

$$\begin{aligned}
a_i &= 3.682 (t_p / d_b)^3 - 0.085 \\
&= 3.682 (0.4375 / 0.75)^3 - 0.085 = 0.65 \text{ in.}
\end{aligned}$$

$$F'_i = \frac{t_p^2 F_{py} \left[0.85 \left(\frac{b_p}{2} \right) + 0.80w' \right] + \frac{\pi d_b^3 F_t}{8}}{4 p_{f,i}}$$

$$= \frac{0.4375^2(50) \left[0.85 \left(\frac{8.0}{2} \right) + 0.80(3.19) \right] + \frac{\pi(0.75)^3 90}{8}}{4(1.75)}$$

$$= 10.3 \text{ k}$$

$$Q_{max,i} = \frac{w't_p^2}{4a_i} \sqrt{F_{py}^2 - 3 \left(\frac{F'_i}{w't_p} \right)^2}$$

$$= \frac{3.19(0.4375)^2}{4(0.65)} \sqrt{(50)^2 - 3 \left(\frac{10.3}{3.19(0.4375)} \right)^2}$$

$$= 11.4 \text{ k}$$

and for the outer bolts,

$$a_o = \min \text{ of } 0.65 \text{ in. or } (p_{ext} - p_{f,o}) = 5 - 2.5 = 2.5 \text{ in.}$$

$$\therefore a_o = 0.65 \text{ in.}$$

$$F'_o = F'_i(p_{f,i} / p_{f,o}) = 10.3(1.75 / 2.5) = 7.21 \text{ k}$$

$$Q_{max,o} = \frac{w't_p^2}{4a_o} \sqrt{F_{py}^2 - 3 \left(\frac{F'_o}{w't_p} \right)^2}$$

$$= \frac{3.19(0.4375)^2}{4(0.65)} \sqrt{(50)^2 - 3 \left(\frac{7.21}{3.19(0.4375)} \right)^2}$$

$$= 11.6 \text{ k}$$

3.) Calculate the connection design strength for the limit state of bolt rupture with prying action,

$$P_t = \pi d_b^2 F_t / 4 = \pi(0.75)^2 90 / 4 = 39.8 \text{ k}$$

$$\phi M_q = \max \begin{cases} \phi [2(P_t - Q_{max,o})d_0 + 2(P_t - Q_{max,i})(d_1 + d_3) + 2(T_b)d_2] \\ \phi [2(P_t - Q_{max,o})d_0 + 2(T_b)(d_1 + d_2 + d_3)] \\ \phi [2(P_t - Q_{max,i})(d_1 + d_3) + 2(T_b)(d_0 + d_2)] \\ \phi [2(T_b)(d_0 + d_1 + d_2 + d_3)] \end{cases}$$

$$T_b \approx 0.7P_t = 0.7(39.8) = 27.9 \text{ k, or from Table J3.1,}$$

Use $T_b = 28 \text{ k}$

$$\phi M_q = \max \begin{cases} 0.75 [2(39.8 - 11.6)38.313 + 2(39.8 - 11.4)(33.688 + 28.688) + 2(28)31.188] = 5588 \text{ k-in.} \\ 0.75 [2(39.8 - 11.6)38.313 + 2(28)(33.688 + 31.188 + 28.688)] = 5550 \text{ k-in.} \\ 0.75 [2(39.8 - 11.4)(33.688 + 28.688) + 2(28)(38.313 + 31.188)] = 5576 \text{ k-in.} \\ 0.75 [2(28)(38.313 + 33.688 + 31.188 + 28.688)] = 5539 \text{ k-in.} \end{cases}$$

4.) Check that $\phi M_q > M_u$. If necessary, adjust the bolt diameter until ϕM_q is greater than M_u .

Summary:	$t_p = 7/16 \text{ in.}$
	$d_b = 3/4 \text{ in.}$

$\phi M_q = 5588 > 4600 \text{ k-in.}$ so the trial bolt, $3/4 \text{ in dia.}$ is ok.

Comparison of Results for the Two Design Procedures

Design Procedure 1

End-Plate: A572 Gr 50 material

$$t_p = 1/2 \text{ in.}$$

Bolts: A325

$$d_b = 5/8 \text{ in.}$$

Design Procedure 2

End-Plate: A572 Gr 50 material

$$t_p = 7/16 \text{ in.}$$

Bolts: A325

$$d_b = 3/4 \text{ in.}$$

As expected, Design Procedure 1 results in a thicker end-plate and smaller diameter bolts than Design Procedure 2. Either design is acceptable. Note: A check of the design strength of the two designs using the procedure outlined in Appendix B yields the following:

Design Procedure 1: $\phi M_n = 5460 \text{ k-in.}$ (Thick plate-behavior controlled by bolt rupture – no prying action)

Design Procedure 2: $\phi M_n = 4935 \text{ k-in.}$ (Thin plate behavior controlled by end-plate yielding)

A comparison of Examples 4.2.4 and 4.2.5 shows that the addition of the stiffener reduces the end-plate thickness by 1/8 inch for both design procedures. The bolt size is unaffected.

Chapter 5

GABLE FRAME PANEL ZONE DESIGN

5.1 Introduction

The panel zone plate of a gable frame is defined as the web plate in the knee area. The knee area is defined as that portion of the frame that connects a column section to a rafter section, Figure 5-1. The panel zone plate is stiffened on two sides by the continuation of the outside column and rafter flanges. A full depth rafter web stiffener (which may be a moment connection end-plate), approximately aligned with the inside column flange as shown in Figure 5-2, stiffens the third side. Either a full depth or partial depth column web stiffener, approximately aligned with the inside rafter flange as shown in Figures 5-2a and 5-2b, respectively, is connected to the fourth side. A full depth stiffener is welded to both the inside and outside column flanges; a partial depth stiffener is welded only to the inside column flange.

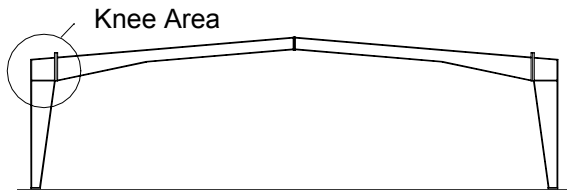

Figure 5-1 Knee area of gable frame.

Possible limit states for panel zone plates are elastic plate buckling, inelastic plate buckling, post-buckling strength due to formation of a tension field (as shown in Figure 5-3) and plate yielding. All of these limit states are possible for negative moment loading (tension on the outside of the knee area) if full depth stiffeners are used. It has been shown that tension field action will not develop if partial depth stiffeners are used (Murray 1986) or for positive moment loading (Young and Murray 1996).

For a buckled web plate to develop tension field action, the tension field must be anchored at both ends, locations A and B in Figure 5-3 for negative moment. Tests have shown that if a partial depth stiffener is used the tension field will not anchor at location A and the additional strength associated with a tension field will not develop. Similarly, anchorage at the outside corner of the knee area is not sufficient to fully develop a tension field if positive moment exits.

The AISC ASD and LRFD Specifications have provisions only for the design of panel zone web plates in beam-to-column joints in multi-story frames. The assumed limit state for these rules is shear yielding; plate buckling checks are not required. However, plate buckling is usually the controlling limit state of panel zone plates in gable frames using built-up columns and rafters.

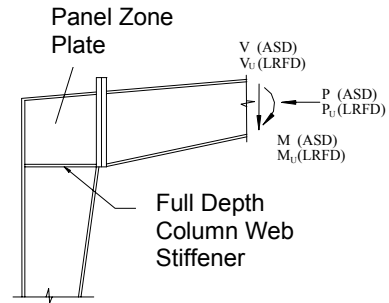

Figure 5-2a Knee with full depth stiffener.

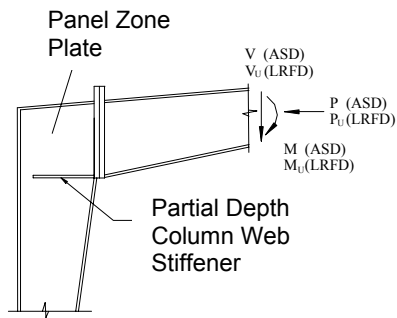

Figure 5-2b Knee with partial depth stiffener.

Design rules for such plates have been developed (Murray 1986) as presented in LRFD and ASD formats in the following sections.

Use of these design rules requires that the combined width of the panel zone web stiffeners be approximately the same as the rafter flange width and of the same thickness as the rafter flange. Stiffener-to-column flange welds must be large enough to develop the yield strength of the portion of the stiffener in contact with the column flange (stiffener width minus clip required for web-to-column flange clearance). The stiffener-to-column web weld must

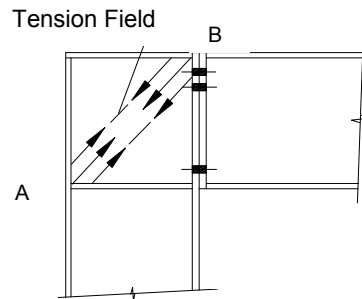

Figure 5-3 Panel zone tension field.

be sufficient to resist the yield strength of the stiffener.

The following design procedures are restricted to gable frame panel zones and engineering judgment is required for other applications; however, these procedures are not applicable to panel zones in high-rise buildings.

5.2 LRFD Rules and Example Calculations

5.2.1 LRFD Rules

Panel zone plates in the gable frames can be designed using AISC LRFD rules for webs of plate girders. When using these equations the parameter h is the depth of the panel zone plate at the rafter side (see Figure 5-4). The required shear strength is calculated from:

$$V_u = \frac{M_u}{h} - \frac{P_u}{2} \quad (5-1)$$

where

M_u = required flexural strength

P_u = required thrust

Both M_u and P_u at the rafter face of the panel zone are determined using factored loads.

The design shear strength, $\phi_v V_n$, is determined according to Section A-G3 of the AISC LRFD Specification as follows:

1. Panel Zone Subject to Negative Moment and with Full Depth Column Web Stiffeners

a) For $h/t_w \leq 1.10\sqrt{k_v E / F_{yw}} = 187\sqrt{\frac{k_v}{F_{yw}}}$

$$\phi_v V_n = \phi_v (0.6 A_w F_{yw}) \quad (5-2)$$

b) For $h/t_w > 1.10\sqrt{k_v E / F_{yw}} = 187\sqrt{\frac{k_v}{F_{yw}}}$

$$\phi_v V_n = \phi_v (0.6 A_w F_{yw}) \left(C_v + \frac{1 - C_v}{1.15\sqrt{1 + (a_v/h)^2}} \right) \quad (5-3)$$

where

$$\phi_v = 0.90$$

$$A_w = a_v \times t_w$$

a_v = width of panel zone at the column top (see Figure 5-4)

t_w = panel zone plate thickness

F_{yw} = yield stress of the panel plate material

$$k_v = 5 + \frac{5}{(a_v/h)^2}$$

C_v = shear coefficient determined as follows:

i) For $1.10\sqrt{k_v E / F_{yw}} < \frac{h}{t_w} \leq 1.37\sqrt{k_v E / F_{yw}}$

or

$$187\sqrt{\frac{k_v}{F_{yw}}} < \frac{h}{t_w} \leq 235\sqrt{\frac{k_v}{F_{yw}}}$$

$$C_v = \frac{1.10\sqrt{k_v E / F_{yw}}}{h/t_w} = \frac{187\sqrt{k_v / F_{yw}}}{h/t_w} \quad (5-4)$$

ii) For $\frac{h}{t_w} > 1.37\sqrt{k_v E / F_{yw}} = 234\sqrt{\frac{k_v}{F_{yw}}}$

$$C_v = \frac{1.51k_v E}{(h/t_w)^2 F_{yw}} = \frac{44,000k_v}{(h/t_w)^2 F_{yw}} \quad (5-5)$$

Use of the above provisions requires that the column stiffener be welded to both column flanges and the panel zone plate.

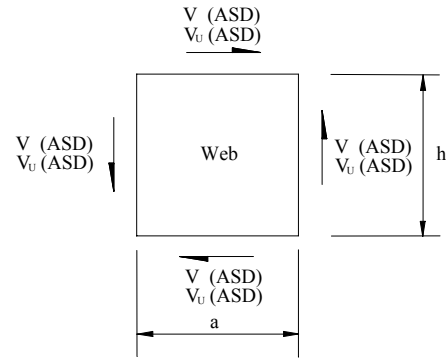

Figure 5-4 Panel zone plate shear forces.

2. Panel Zone Subject to Positive Moment or Subject to Negative Moment with Partial Depth Column Web Stiffeners

a) For $h/t_w \leq 1.10\sqrt{k_v E / F_{yw}} = 187\sqrt{\frac{k_v}{F_{yw}}}$

$$\phi_v V_n = \phi_v (0.6 A_w F_{yw}) \quad (5-6)$$

b) For $h/t_w > 1.10\sqrt{k_v E / F_{yw}} = 187\sqrt{\frac{k_v}{F_{yw}}}$

$$\phi_v V_n = \phi_v (0.6 A_w F_{yw}) C_v \quad (5-7)$$

Partial depth column web stiffeners must terminate within 1 in. of the outside column flange and be welded to the inside column flange and the panel zone plate.

5.2.2 LRFD Example Calculations

Example 1. Full Depth Column Web Stiffener:

For the panel zone dimensions shown in Figure 5-5, determine if a ¼ in. thick plate is adequate for a negative

moment, $M_u = 9,600$ k-in, and $P_u = 75$ kips. Material is A572, Gr 50 steel. Weld metal is 70 ksi.

1. Determine the required shear strength:

$$V_u = \frac{M_u}{h} - \frac{P_u}{2}$$

$$= \frac{9,600}{47.125} - \frac{75}{2} = 166.2 \text{ kips}$$

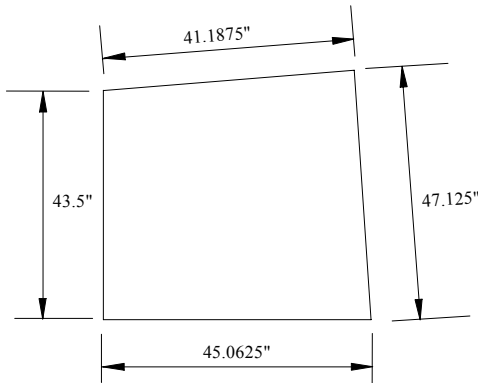
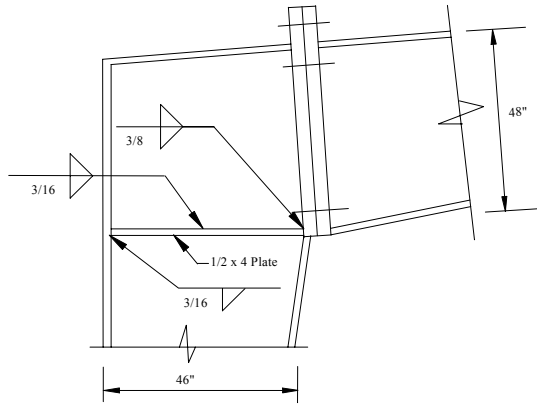

Figure 5-5 Example details.

2. Determine shear design strength assuming tension field action:

$$h = 47.125 \text{ in}$$

$$t_w = 0.25 \text{ in}$$

$$h/t_w = 47.125/0.25 = 188.5$$

$$a_v = 41.1875 \text{ in.}$$

$$a_v/h = 41.1875/47.125 = 0.874$$

$$k_v = 5 + \frac{5}{(0.874)^2} = 11.55$$

$$A_w = a_v \times t_w = 41.1875(0.25) = 10.30 \text{ in}^2$$

Since

$$h/t_w = 188.5 > 187\sqrt{k_v/F_{yw}} = 187\sqrt{11.55/50} = 89.9$$

$$\phi_v V_n = \phi_v (0.6 A_w F_{yw}) \left(C_v + \frac{1 - C_v}{1.15\sqrt{1 + (a/h)^2}} \right)$$

where, since

$$h/t_w = 188.5 > 234\sqrt{k_v/F_{yw}} = 234\sqrt{11.55/50} = 112.5$$

$$C_v = \frac{44,000k_v}{(h/t_w)^2 F_{yw}} = \frac{44,000(11.55)}{(188.5)^2 (50)} = 0.286$$

then

$$\phi_v V_n = 0.90(0.6 \times 10.30 \times 50) \left(0.286 + \frac{1 - 0.286}{1.15\sqrt{1 + (0.874)^2}} \right)$$

$$= 209.5 \text{ kips}$$

3. Check adequacy:

Since $V_u = 166.2$ kips $<$ $\phi_v V_n = 209.5$ kips, a $1/4$ in. thick, A572 Gr. 50 panel zone plate is adequate if a full depth stiffener, welded to both flanges and the panel zone plate is used.

4. Check Weld Strength (See Figure 5-5):

a.) Stiffener-to-Flange Welds

Assume $3/4$ in. clip, then for one plate

$$A_{net} = (4 - 3/4)(1/2) = 1.625 \text{ in}^2$$

The welds must develop the yield strength of the plate:

$$\phi_t T_n = 0.90 F_y A_{net} = 0.90(50)(1.625) = 73.1 \text{ kips}$$

From the AISC LRFD Specification Appendix J2,

$$F_w = 0.60 F_{EXX} (1.0 + 0.5 \sin^{1.5} \theta)$$

with $F_{EXX} = 70$ ksi and $\theta = 90^\circ$

$$F_w = 0.60(70)(1.5) = 63.1 \text{ ksi}$$

The $3/8$ in. fillet weld design strength is then

$$\phi R_n = 0.75 F_w A_{weld}$$

$$= 0.75(63.0)(0.707 \times 0.375)(2 \times 3.25)$$

$$= 81.4 \text{ k} > 73.1 \text{ k} \quad \text{OK}$$

b) Stiffener-to-Panel Zone Plate Welds

With $\theta = 0^\circ$,

$$F_w = 0.60(70.0)(1.0) = 42.0 \text{ ksi}$$

The 3/16 in. fillet weld design strength is then

$$\begin{aligned} \phi R_n &= 0.75(42.0)(0.707 \times 0.1875)(2 \times 45) \\ &= 375.8 \text{ k} > 73.1 \text{ k} \quad \text{OK} \end{aligned}$$

The welds shown are sufficient.

Note: The 3/16 in. stiffener-to-panel zone plate weld is the minimum size permitted by the AISC LRFD Specification.

Example 2. Partial Depth Column Web Stiffener:

For the dimensions and loading of the previous example, determine the required panel zone plate thickness if a partial depth column web stiffener is used. Material is A572, Gr 50 steel.

1. Determine the required shear strength:

$$\begin{aligned} V_u &= \frac{M_u}{h} - \frac{P_u}{2} \\ &= \frac{9,600}{47.125} - \frac{75}{2} = 166.2 \text{ kips} \end{aligned}$$

2. Determine shear design strength without tension field action:

$$\begin{aligned} h &= 47.125 \text{ in} \\ t_w &= 0.25 \text{ in} \\ h/t_w &= 47.125/0.25 = 188.5 \\ a_v &= 41.1875 \text{ in.} \\ a_v/h &= 41.1875/47.125 = 0.874 \end{aligned}$$

$$k_v = 5 + \frac{5}{(0.874)^2} = 11.55$$

Assuming that

$$h/t_w \leq 187\sqrt{k_v/F_{yw}} = 187\sqrt{11.55/50} = 89.9$$

Then

$$\phi_v V_n = \phi_v (0.6 A_w F_{yw})$$

and, with $\phi_v V_n = V_u$, the required area is

$$A_w = \frac{V_u}{\phi_v (0.6 F_{yw})} = \frac{166.2}{0.90(0.6 \times 50)} = 6.15 \text{ in}^2$$

With $A_w = a_v \times t_w = 41.1875 t_w$, the required plate thickness is 0.149 in.

Try 3/16 in. plate

3. Check adequacy:

$$h/t_w = 47.125/0.1875 = 251.3 > 89.9 \quad \text{NG}$$

Now, assume

$$h/t_w > 234\sqrt{k_v/F_{yw}} = 234\sqrt{11.55/50} = 112.5$$

Then, from Equations (5-7) and (5-5)

$$\phi_v V_n = \phi_v (0.6 A_w F_{yw}) \left(\frac{44,000 k_v}{(h/t_w)^2 F_{yw}} \right)$$

with $\phi_v V_n = V_u$ and $A_w = a_v \times t_w$, solving for t_w :

$$\begin{aligned} t_w &= \sqrt[3]{\frac{V_u h^2}{\phi_v (0.6 a_v) (44,000 k_v)}} \\ &= \sqrt[3]{\frac{166.2(47.125)^2}{0.90(0.6 \times 41.1875)(44,000 \times 11.55)}} \\ &= 0.320 \text{ in.} \end{aligned}$$

Try 3/8 in. plate

Check assumption:

$$h/t_w = 47.125/0.375 = 125.7 > 112.5 \quad \text{OK}$$

Use a 3/8 in. thick, A572 Gr. 50 panel zone plate with a partial depth stiffener welded to the inside column flange and cut 1 in. short of the outside column flange.

4. Design of Welds

Since welds must develop the strength of the connected portion of the stiffeners, weld sizes will be the same as shown in Figure 5-5 except that no weld is required at the outside column flange.

5.3 Allowable Stress Design Rules and Example Calculations

5.3.1 Allowable Stress Design Rules

Panel zone plates in gable frames can be designed using the AISC allowable stress design rules for webs of plate girders. When using these equations the parameter h is the depth of the panel zone plate at the rafter side (Murray 1986). The applied shear stress is calculated from

$$f_v = \frac{V}{a_v t_w} \quad (5-8)$$

where

a_v = width of the panel zone at the column top
 t_w = panel zone plate thickness and

$$V = \frac{M}{h} - \frac{P}{2} \quad (5-9)$$

where

M = applied moment

P = applied thrust

Both M and P , from service load analyses, are at the rafter face of the panel zone.

The allowable shear stress, F_v , is determined as follows:

1. Panel Zone Subject to Negative Moment with Full Depth Column Web Stiffener
- 2.

$$F_v = \frac{F_y}{2.89} \left(C_v + \frac{1 - C_v}{1.15\sqrt{1 + (a_v/h)^2}} \right) \leq 0.40F_y \quad (5-10)$$

where

$$C_v = \frac{45,000k_v}{F_y(h/t_w)^2} \quad \text{when } C_v < 0.8$$

$$= \frac{190}{h/t_w} \sqrt{k_v/F_y} \quad \text{when } C_v > 0.8$$

$$k_v = 4.00 + \frac{5.34}{(a_v/h)^2} \quad \text{when } a_v/h < 1.0$$

$$= 5.34 + \frac{4.00}{(a_v/h)^2} \quad \text{when } a_v/h > 1.0$$

Use of the above provisions requires that the column web stiffener be welded to both column flanges and the panel zone plate.

2. Panel Zone Subject to Positive Moment or Subject to Negative Moment with Partial Depth Column Web Stiffener

$$F_v = \frac{F_y}{2.89} (C_v) \leq 0.40F_y \quad (5-11)$$

A partial depth column web stiffener must terminate within 1 in. of the outside column flange and be welded to the inside column flange and the panel zone plate.

5.3.2 ASD Example Calculations

Example 1. Full Depth Column Web Stiffener:

For the panel zone dimensions shown in Figure 5-5, determine if a ¼ inch thick plate is adequate for $M = 6,300$ k-in and $P = 50$ kips. Material is A572, Gr 50 steel. Weld metal is 70 ksi.

1. Determine applied shear stress, f_v with $h = 47.125$ in and $a_v = 41.875$ in.:

$$V = \frac{M}{h} - \frac{P}{2} = \frac{6,300}{47.125} - \frac{50}{2} = 108.7 \text{ kips}$$

$$f_v = \frac{V}{a_v t_w} = \frac{108.7}{41.1875(0.25)} = 10.56 \text{ ksi}$$

2. Determine the allowable shear stress, F_v :

$$h = 47.125 \text{ in.}$$

$$t_w = 0.25 \text{ in.}$$

$$h/t_w = 47.125/0.25 = 188.5$$

$$a_v = 41.875 \text{ in.}$$

$$a_v/h = 41.875/47.125 = 0.874 < 1.0$$

$$k_v = 4.00 + \frac{5.34}{(a_v/h)^2}$$

$$= 4.00 + \frac{5.34}{(0.874)^2} = 10.99$$

Assuming $C_v < 0.8$, then

$$C_v = \frac{45,000k_v}{F_y(h/t_w)^2} = \frac{45,000(10.99)}{50(188.5)^2} = 0.278 < 0.8 \quad \text{OK}$$

Since the column web stiffener is full depth, Equation 5-10 applies

$$F_v = \frac{F_y}{2.89} \left(C_v + \frac{1 - C_v}{1.15\sqrt{1 + (a_v/h)^2}} \right) \leq 0.40F_y$$

$$= \frac{50}{2.89} \left(0.278 + \frac{1 - 0.278}{1.15\sqrt{1 + (0.874)^2}} \right)$$

$$= 13.0 \text{ ksi} < 0.40F_y = 0.40(50) = 20.0 \text{ ksi}$$

3. Check adequacy:

Since $f_v = 10.56 \text{ ksi} < F_v = 13.0 \text{ ksi}$, a ¼ in. thick panel zone plate is adequate.

4. Check Weld Strength:

- i.) Stiffener-to-Flange Welds

Assume ¾ in. clip, then for one plate

$$A_{net} = (4 - 3/4)(1/2) = 1.625 \text{ in}^2$$

The welds must develop the yield capacity of the plate:

$$T_p = 0.60F_y A_{net} = 0.60(50)(1.625) = 48.75 \text{ kips}$$

From the AISC ASD Specification,

$$F_w = 0.3F_{EXX} = 0.3(70) = 21 \text{ ksi}$$

The 3/8 in. fillet weld capacity is then

$$\begin{aligned} T_w &= F_w A_{weld} \\ &= (21)(0.707 \times 0.375)(2 \times 3.25) \\ &= 36.2 \text{ k} < 48.75 \text{ k} \quad \underline{\text{NG}} \end{aligned}$$

Use full penetration groove weld.

ii) Stiffener-to-Panel Zone Plate Welds

$$\begin{aligned} T_w &= (21.0)(0.707 \times 0.1875)(2 \times 45) \\ &= 250.5 \text{ k} > 48.75 \text{ k} \quad \underline{\text{OK}} \end{aligned}$$

Note: The 3/16 in. stiffener-to-panel zone plate weld is the minimum size permitted by the AISC LRFD Specification.

Example 2. Partial Depth Column Web Stiffener:

For the dimensions and loading of the previous example, determine the required panel zone plate thickness if a partial depth column web stiffener is used. Material is A572, Gr 50 steel.

From the previous example,

$V = 108.7$ kips and $k = 10.99$.

1. Determine the required panel zone plate thickness: Assume $C_v < 0.8$, then from Equation (5-11) and the appropriate C_v relationship

$$F_v = \frac{F_y}{2.89} \frac{45,000k}{F_y (h/t_w)^2}$$

with $F_v = f_v = V/(a_v \times t_w)$, solving for t_w

$$t_w = \sqrt[3]{\frac{2.89Vh^2}{45,000k_v a_v}} = \sqrt[3]{\frac{2.89(108.7)(47.125)^2}{45,000(10.99)(41.1875)}} = 0.325 \text{ in.}$$

Try 3/8 in. plate and check C_v assumption

$$\begin{aligned} C_v &= \frac{45,000k_v}{F_y (h/t_w)^2} \\ &= \frac{45,000(10.99)}{50(47.125/0.375)^2} = 0.626 < 0.8 \quad \underline{\text{OK}} \end{aligned}$$

Use 3/8 in., A572 Gr. 50, panel zone plate with partial depth web stiffeners welded to the inside column flange and cut 1 in. short of the outside column flange.

2. Design of Welds

Since welds must develop the capacity of the connected portion of the stiffeners, weld sizes will be the same as determined in the previous ASD example except that no weld is required at the outside column flange.

REFERENCES

- Abel, M. S. and Murray, T. M. (1992a) "Multiple Row, Extended Unstiffened End-Plate Connection Tests," Research Report CE/VPI-ST-92/04, Department of Civil Engineering, Virginia Polytechnic Institute and State University, Blacksburg, VA, August 1992.
- Abel, M. S. and Murray, T. M. (1992b) "Analytical and Experimental Investigation of the Extended Unstiffened Moment End-Plate Connection with Four Bolts at the Beam Tension Flange," Research Report CE/VPI-ST-93/08, Department of Civil Engineering, Virginia Polytechnic Institute and State University, Blacksburg, VA, December, Revised October 1994.
- Agerskov, H. (1976) "High Strength Bolted Connections Subject to Prying." *Journal of the Structural Division*, ASCE, Vol. 102, ST1, 161-175.
- Agerskov, H. (1977) "Analysis of Bolted Connections Subject to Prying." *Journal of the Structural Division*, ASCE, Vol. 103 ST11, 2145-2163.
- Ahuja, V. (1982) "Analysis of Stiffened End-Plate Connections Using Finite Element Method." Master of Science Thesis, School of Civil Engineering and Environmental Science, University of Oklahoma, Norman, Oklahoma.
- AISC, (1970) *Manual of Steel Construction*, 7th Ed., American Institute of Steel Construction, Chicago, IL.
- AISC, (1980) *Manual of Steel Construction*, 8th Ed., American Institute of Steel Construction, Chicago, IL.
- AISC, (1986) *Manual of Steel Construction - Load and Resistance Factor Design*, 1st Ed., American Institute of Steel Construction, Chicago, IL.
- AISC, (1989) *Allowable Stress Design Specification for Structural Steel Buildings*, American Institute of Steel Construction, Chicago, IL.
- AISC, (1989) *Manual of Steel Construction - Allowable Stress Design*, 9th Ed., American Institute of Steel Construction, Chicago, IL.
- AISC, (1994) *Manual of Steel Construction - Load and Resistance Factor Design*, 2nd Ed., American Institute of Steel Construction, Chicago, IL.
- AISC, (1999) *Load and Resistance Factor Design Specification for Structural Steel Buildings*, American Institute of Steel Construction, Chicago, IL.
- ATC, (1992) *Guidelines for Cyclic Seismic Testing of Components of Steel Structures*, ATC-24, Redwood City, CA.
- Bahaari, M.R. and Sherbourne, A.N. (1993) "Modeling of Extended End-plate Bolted Connections." *Proceedings of the National Steel Structures Congress*, AISC, 731-736.
- Bjorhovde, R., Brozzetti, J. and Colson, A. (1987) "Classification of Connections," *Connections in Steel Structures - Behaviour, Strength and Design*, Elsevier Applied Science, 388-391.
- Bjorhovde, R., Colson, A. and Brozzetti, J. (1990) "Classification System for Beam-to-Column Connections," *Journal of Structural Engineering*, ASCE, 116(11), pp. 3059-3076.
- Borgsmiller, J. T. and Murray, T. M., (1995) "'Simplified Method for the Design of Moment End-Plate Connections," Research Report CE/VPI-ST-95/19, Department of Civil Engineering, Virginia Polytechnic Institute and State University, Blacksburg, VA, November, 1995.
- Bursi, O.S. and Leonelli, L (1994) "A Finite Element Model for the Rotational Behavior of End Plate Steel Connections", *SSRC Proceedings 1994 Annual Task Group Technical Session*, Leigh University, 162-175.
- Carter, C. J. (1999) "Stiffening of Wide-Flange Columns at Moment Connections: Wind and Seismic Applications", AISC Design Guide No. 13, American Institute of Steel Construction, Chicago, IL.
- Disque, R.O. (1962) "End-Plate Connections," *National Engineering Conference Proceedings*, AISC, 1962, pp. 30-37.
- Douty, R.T. and McGuire, S. (1965) "High Strength Bolted Moment Connections." *Journal of the Structural Division*, ASCE, Vol. 91 ST2, 101-126.
- FEMA (2000) "Recommended Seismic Design Criteria for New Steel Moment-Frame Buildings", Program to Reduce the Earthquake Hazards of Steel Moment-Frame Structures, FEMA 350, Federal Emergency Management Agency, Washington, D.C.
- Fleischman, R. B., Chasten, C. P., Lu, L-W, and Driscoll, G. C., (1991) "Top-and-Seat Angle Connections and

- End-Plate Connections: Snug vs. Fully Pretensioned Bolts,” *AISC Engineering Journal*, 1st Qtr., 28, 18-28.
- Ghassemieh, M. (1983) “Inelastic Finite Element Analysis of Stiffened End-Plate Moment Connections.” Master of Science Thesis, School of Civil Engineering and Environmental Science, University of Oklahoma, Norman, Oklahoma.
- Granstrom, A. (1980) “Bolted End-Plate Connections.” *Stalbyggnads Institute SBI Report 86.3*, September, 5-12.
- Griffiths, J.D. (1984) “End-Plate Moment Connections - Their Use and Misuse.” *AISC Engineering Journal*, 1st Qtr., 21, 32-34.
- Hasan, R., Kishi, N. and Chen, W.F. (1997) “Evaluation of Rigidity of Extended End-Plate Connections,” *Journal of Structural Engineering*, ASCE, 123(12), pp. 1595-1602.
- Hendrick, D., Kukreti, A. and Murray, T. (1984) “Analytical and Experimental Investigation of Stiffened Flush End-Plate Connections with Four Bolts at the Tension Flange,” Research Report FSEL/MBMA 84-02, Fears Structural Engineering Laboratory, University of Oklahoma, Norman, OK, September.
- Hendrick, D., Kukreti, A. and Murray, T. (1985) “Unification of Flush End-Plate Design Procedures,” Research Report FSEL/MBMA 85-01, Fears Structural Engineering Laboratory, University of Oklahoma, Norman, OK, March.
- Kato, B. and McGuire, W.F., (1973) “Analysis of T-Stub Flange-to-Column Connections,” *Journal of the Structural Division*, ASCE, Vol. 99 ST5, 865-888.
- Kennedy, N.A., Vinnakota, S. and Sherbourne, A.N. (1981) “The Split-Tee Analogy in Bolted Splices and Beam-Column Connections,” *Proceedings of the International Conference on Joints in Structural Steelwork*, 2.138-2.157.
- Kline, D., Rojiani, K., and Murray, T. (1989) “Performance of Snug Tight Bolts in Moment End-Plate Connections,” MBMA Research Report, Department of Civil Engineering, Virginia Polytechnic Institute and State University, Blacksburg, VA, February, Revised July 1995.
- Krishnamurthy, N. and Graddy, D., (1976) “Correlation Between 2- and 3-Dimensional Finite Element Analysis of Steel Bolted End Plate Connections,” *Computers and Structures*, Vol. 6 (4/5), 381-389, August/October.
- Krishnamurthy, N. (1978) “A Fresh Look at Bolted End-Plate Behavior and Design”, *AISC Engineering Journal*, 2nd Qtr., 15, 39-49.
- Kukreti, A.R., Murray, T.M. and Abolmaali, A. (1987) “End-Plate Connection Moment-Rotation Relationship,” *Journal of Constructional Steel Research*, Vol. 8, 137-157.
- Kukreti, A.R., Ghassemieh, M. and Murray, T.M. (1990) “Behavior and Design of Large-Capacity Moment End-Plates,” *Journal of Structural Engineering*, Vol. 116 (3), 809-828.
- Mann, A.P. and Morris, L.J. (1979) “Limit Design of Extended End-Plate Connections,” *Journal of the Structural Division*, ASCE, Vol. 105 ST3, 511-526.
- Meng, R. L., (1996) “Moment End-Plate Connections for Seismic Loading,” Ph.D. Dissertation, Virginia Polytechnic Institute and State University, Blacksburg, Virginia.
- Meng, R. L. and Murray, T. M., (1997) “Seismic performance of Bolted end-Plate Moment Connections,” *Proceedings, AISC National Steel Construction Conference*, Chicago, IL, May 7-9, 30-1 to 30-14.
- Morrison, S. J., Astaneh-Asl, A. and Murray, T. (1985) “Analytical and Experimental Investigation of the Extended Stiffened Moment End-Plate Connection with Four Bolts at the Beam Tension Flange,” Research Report FSEL/MBMA 85-05, Fears Structural Engineering Laboratory, University of Oklahoma, Norman, OK, December.
- Morrison, S. J., Astaneh-Asl, A. and Murray, T. (1986) “Analytical and Experimental Investigation of the Multiple Row Extended 1/3 Moment End-Plate Connection with Eight Bolts at the Beam Tension Flange,” Research Report FSEL/MBMA 86-01, Fears Structural Engineering Laboratory, University of Oklahoma, Norman, OK, May.
- Murray, T. M. (1986), “Stability of Gable Frame Panel Zone Plates,” *Proceedings of the Structural Stability Research Council Annual Technical Session*, Structural Stability Research Council, Bethlehem, PA, pp. 317-325.
- Murray, T. M. (1988) “Recent Developments for the Design of Moment End-Plate Connections,” *Journal of Constructional Steel Research*, Vol. 10, 133-162.

- Murray, T. M. (1990) "Extended End-Plate Moment Connections," AISC Design Guide No. 4, American Institute of Steel Construction, Chicago, IL.
- Murray, T. M., Kline, D. P. and Rojiani, K. B., (1992) "Use of Snug-Tightened Bolts in End-Plate Connections," *Connections in Steel Structures II: Behavior, Strength and Design*, Edited by R. Bjorhovde et al., American Institute of Steel Construction, Chicago, IL, 27-34.
- Nair, R., Birkemoe, P. and Munse, W. (1974) "High Strength Bolts Subject to Tension and Prying." *Journal of the Structural Division*, ASCE, Vol. 100 ST2, 351-372.
- Packer, J. and Morris, L. (1977) "A Limit State Design Method for the Tension Region of Bolted Beam-Column Connections," *The Structural Engineer*, Vol. 55 No. 10, 446-458.
- Popov, E. and Tsai, K.C. (1989) "Performance of Large Seismic Steel Moment Connections Under Cyclic Loads," *AISC Engineering Journal*, 2nd Qtr., 12, 51-60.
- Research Council on Structural Connections, (1985) *Specification for Structural Joints Using ASTM A325 and A490 Bolts*.
- Research Council on Structural Connections, (2000) *Specification for Structural Joints Using ASTM A325 and A490 Bolts*.
- Salmon, C. and Johnson, J. (1980) *Steel Structures, Design and Behavior*, 2nd Ed., Harper & Row, New York, New York.
- SEI (1984), "Multiple Row, Extended End-Plate Connection Tests," Research Report, Structural Engineers, Inc., Norman, OK, December.
- Srouji, R., Kukreti, A. R. and Murray, T. M. (1983a) "Strength of Two Tension Bolt Flush End-Plate Connections," Research Report FSEL/MBMA 83-03, Fears Structural Engineering Laboratory, University of Oklahoma, Norman, OK, July.
- Srouji, R., Kukreti, A. R. and Murray, T. M. (1983b) "Yield-Line Analysis of End-Plate Connections With Bolt Force Predictions," Research Report FSEL/MBMA 83-05, Fears Structural Engineering Laboratory, University of Oklahoma, Norman, OK, December.
- Sumner, E. A., Mays, T. W. and Murray, T. M. (2000) "Cyclic Testing of Bolted Moment End-Plate Connections," Research Report No. CE/VPI-ST 00/03, Department of Civil and Environmental Engineering, Virginia Polytechnic Institute and State University, Blacksburg, VA, May.
- Sumner, E. A. and Murray, T. M. (2001) "Experimental Investigation of the MRE 1/2 End-Plate Moment Connection," Research Report No. CE/VPI-ST 14/01, Department of Civil and Environmental Engineering, Virginia Polytechnic Institute and State University, Blacksburg, VA, December.
- Young, J. and Murray, T. M., (1996) "Experimental Investigation of Positive Bending Moment Strength of Rigid Knee Connections," Research Report No. CE/VPI-ST 9617, Department of Civil Engineering, Virginia Polytechnic Institute and State University, Blacksburg, VA, December.

Appendix A

NOMENCLATURE

A_b	= nominal bolt area	E	= Young's modulus of elasticity
A_{net}	= net area of web stiffener	F	= applied force
A_w	= panel zone web area = $a_v \times t_w$	F_{py}	= end-plate material yield stress
A_{weld}	= effective area of weld throat	F_y	= yield stress
a	= distance from the bolt centerline to the prying force	F_{yw}	= yield stress of panel plate material
a_i	= distance from the interior bolt centerline to the prying force	F_t	= bolt material tensile strength, specified in Table J3.2, AISC (1993)
a_o	= distance from the outer bolt centerline to the prying force	F_w	= nominal strength of weld electrode material
a_v	= width of panel zone	F'	= flange force per bolt at the thin plate limit
B	= bolt force	F'_i	= flange force per bolt at the thin plate limit when calculating $Q_{max,i}$ for end-plate configurations with large inner pitch distances
b_f	= beam flange width	F'_o	= flange force per bolt at the thin plate limit when calculating $Q_{max,o}$ for end-plate configurations with large inner pitch distances
b_p	= end-plate width	g	= bolt gage
C_v	= shear coefficient for panel zone	h	= total beam depth
d_b	= nominal bolt diameter	h_0	= distance from the compression side of the beam to the outer bolt centerline in extended end-plate configurations
d_e	= end-plate extension beyond the exterior bolt centerline = $p_{ext} - p_{f,o}$	h_1	= distance from the compression side of the beam to the farthest inner load-carrying bolt line
d_0	= distance from the center of the beam compression flange to the outer bolt centerline in extended end-plate configurations	h_2	= distance from the compression side of the beam to the second farthest inner load-carrying bolt line
d_1	= distance from the center of the beam compression flange to the farthest inner load-carrying bolt line	h_3	= distance from the compression side of the beam to the third farthest inner load-carrying bolt line
d_2	= distance from the center of the beam compression flange to the second farthest inner load-carrying bolt line	I	= moment of inertia
d_3	= distance from the center of the beam compression flange to the third farthest inner load-carrying bolt line	k_v	= shear buckling coefficient for panel zone
$\sum d_n$	= sum of distances from the centerline of each tension bolt row to the center of the compression flange	L	= beam span
		M	= applied moment
		M_b	= bolt moment capacity
		M_F	= fixed end beam moment

M_n	= nominal connection resistance	R_n	= nominal strength
M_{np}	= connection strength for the limit state of bolt fracture with no prying action	s	= distance from the innermost bolt centerline to the innermost yield line
M_{pl}	= connection strength for the limit state of end-plate yielding	S	= section modulus
M_q	= connection strength for the limit state of bolt fracture with prying action	T_b	= specified pretension load in high strength bolts, Table J3.1, AISC (2000), or if snug-tight, recommended percentage of Table J3.1 based on bolt diameter
M_u	= required flexural strength	T_n	= nominal tensile strength
M_w	= working moment	T_u	= required axial force
P_t	= bolt material ultimate tensile load capacity, proof load = $A_b \times F_t$	t_f	= beam flange thickness
P_u	= required thrust	t_p	= end-plate thickness
p_b	= distance from bolt centerline to bolt centerline	t_s	= stiffener thickness
p_{ext}	= end-plate extension beyond the exterior face of the beam tension flange	t_w	= beam web thickness
p_f	= distance from the bolt centerline adjacent the beam tension flange to the near face of the beam tension flange	V_u	= required shear strength
$p_{f,i}$	= distance from the first interior bolt centerline to the inner face of the beam tension flange	w'	= width of end-plate per bolt minus the bolt hole diameter = $b_p/2 - (d_b + 1/16)$
$p_{f,o}$	= distance from the outer bolt centerline to the outer face of the beam tension flange	Y	= yield-line mechanism parameter
p_s	= distance from the bolt centerline to the near face of the stiffener in four-bolt flush connection with stiffener inside bolt rows	ϕ	= resistance factor for bolt rupture = 0.75
$p_{s,i}$	= distance from the first interior bolt centerline to the inner face of the stiffener in four-bolt flush connection with stiffener between bolt rows	ϕ_b	= resistance factor for end-plate yield = 0.90
$p_{s,o}$	= distance from the outer bolt centerline to the outer face of the stiffener in four-bolt flush connection with stiffener between bolt rows	ϕ_t	= resistance factor for tension = 0.90
Q	= prying force	ϕ_v	= resistance factor for shear = 0.90
Q_{max}	= maximum possible prying force	π	= pi
$Q_{max,i}$	= maximum possible prying force for interior bolts	θ	= beam end-rotation = angle of loading measured from the weld longitudinal axis
$Q_{max,o}$	= maximum possible prying force for outer bolts	θ_s	= simple span beam end rotation
		γ_r	= load factor to limit connection rotation at ultimate moment to 10% of simple span rotation

Appendix B

BOLTED END-PLATE CONNECTION ANALYSIS FLOWCHART

Given: End-plate thickness, Bolt diameter, End-plate and beam geometry, Material properties
Find: Connection Moment Strength

