



17

Steel Design Guide

High Strength Bolts

A Primer for Structural Engineers





17
Steel Design Guide

High Strength Bolts

A Primer for Structural Engineers

Geoffrey Kulak
Professor Emeritus
University of Alberta
Edmonton, Canada

AMERICAN INSTITUTE OF STEEL CONSTRUCTION

Copyright © 2002

by

American Institute of Steel Construction, Inc.

*All rights reserved. This book or any part thereof
must not be reproduced in any form without the
written permission of the publisher.*

The information presented in this publication has been prepared in accordance with recognized engineering principles and is for general information only. While it is believed to be accurate, this information should not be used or relied upon for any specific application without competent professional examination and verification of its accuracy, suitability, and applicability by a licensed professional engineer, designer, or architect. The publication of the material contained herein is not intended as a representation or warranty on the part of the American Institute of Steel Construction or of any other person named herein, that this information is suitable for any general or particular use or of freedom from infringement of any patent or patents. Anyone making use of this information assumes all liability arising from such use.

Caution must be exercised when relying upon other specifications and codes developed by other bodies and incorporated by reference herein since such material may be modified or amended from time to time subsequent to the printing of this edition. The Institute bears no responsibility for such material other than to refer to it and incorporate it by reference at the time of the initial publication of this edition.

Printed in the United States of America

First Printing: October 2002

Second Printing: October 2003

TABLE OF CONTENTS

1. Introduction

1.1 Purpose and Scope	1
1.2 Historical Notes	1
1.3 Mechanical Fasteners	1
1.4 Types of Connections	4
1.5 Design Philosophy	6
1.6 Approach Taken in this Primer	7

2. Static Strength of Rivets

2.1 Introduction	9
2.2 Rivets Subject to Tension	9
2.3 Rivets in Shear	9
2.4 Rivets in Combined Tension and Shear	10

3. Installation of Bolts and Their Inspection

3.1 Introduction	13
3.2 Installation of High-Strength Bolts	13
3.2.1 Turn-of-Nut Installation	14
3.2.2 Calibrated Wrench Installation	17
3.2.3 Pretensions Obtained using Turn-of-Nut and Calibrated Wrench Methods	17
3.2.4 Tension-Control Bolts	18
3.2.5 Use of Direct Tension Indicators	19
3.3 Selection of Snug-Tightened or Pretensioned Bolts	19
3.4 Inspection of Installation	20
3.4.1 General	20
3.4.2 Joints Using Snug-Tight Bolts	21
3.4.3 Joints Using Pretensioned Bolts	21
3.4.4 Arbitration	21

4. Behavior of Individual Bolts

4.1 Introduction	23
4.2 Bolts in Tension	23
4.3 Bolts in Shear	24
4.4 Bolts in Combined Tension and Shear	25

5. Bolts in Shear Splices

5.1 Introduction	27
5.2 Slip-Critical Joints	28
5.3 Bearing-Type Joints	30
5.3.1 Introduction	30
5.3.2 Bolt Shear Capacity	30
5.3.3 Bearing Capacity	31

5.4 Shear Lag	33
5.5 Block Shear	34

6. Bolts in Tension

6.1 Introduction	37
6.2 Single Fasteners in Tension	37
6.3 Bolt Force in Tension Connections	38

7. Fatigue of Bolted and Riveted Joints

7.1 Introduction	41
7.2 Riveted Joints	41
7.3 Bolted Joints	42
7.3.1 Bolted Shear Splices	42
7.3.2 Bolts in Tension Joints	43

8. Special Topics

8.1 Introduction	45
8.2 Use of Washers in Joints with Standard Holes	45
8.3 Oversize or Slotted Holes	45
8.4 Use of Long Bolts or Short Bolts	46
8.5 Galvanized Bolts	46
8.6 Reuse of High-Strength Bolts	47
8.7 Joints with Combined Bolts and Welds	48
8.8 Surface Coatings	48

References	51
------------------	----

Index	55
-------------	----

Chapter 1

INTRODUCTION

1.1. Purpose and Scope

There are two principal types of fasteners used in contemporary fabricated steel structures—bolts and welds. Both are widely used, and sometimes both fastening types are used in the same connection. For many connections, it is common to use welds in the shop portion of the fabrication process and to use bolts in the field. Welding requires a significant amount of equipment, uses skilled operators, and its inspection is a relatively sophisticated procedure. On the other hand, bolts are a manufactured item, they are installed using simple equipment, and installation and inspection can be done by persons with only a relatively small amount of training.

Engineers who have the responsibility for structural design must be conversant with the behavior of both bolts and welds and must know how to design connections using these fastening elements. Design and specification of welds and their inspection methods generally involves selecting standardized techniques and acceptance criteria or soliciting the expertise of a specialist. On the other hand, design and specification of a bolted joint requires the structural engineer to select the type of fasteners, understand how they are to be used, and to set out acceptable methods of installation and inspection. Relatively speaking, then, a structural engineer must know more about high-strength bolts than about welds.

The purpose of this Primer is to provide the structural engineer with the information necessary to select suitable high-strength bolts, specify the methods of their installation and inspection, and to design connections that use this type of fastener. Bolts can be either common bolts (sometimes called ordinary or machine bolts) or high-strength bolts. Although both types will be described, emphasis will be placed on high-strength bolts. Because many riveted structures are still in use and often their adequacy must be verified, a short description of rivets is also provided.

1.2. Historical Notes

Rivets were the principal fastener used in the early days of iron and steel structures [1, 2]. They were a satisfactory solution generally, but the clamping force produced as the heated rivet shrank against the gripped material was both variable and uncertain as to magnitude. Thus, use of rivets as the fastener in joints where slip was to be prevented was problematic. Rivets in connections loaded such that tension was produced in the fastener also posed certain problems. Perhaps most important,

however, the installation of rivets required more equipment and manpower than did the high-strength bolts that became available in a general way during the 1950's. This meant that it was more expensive to install a rivet than to install a high-strength bolt. Moreover, high-strength bolts offered certain advantages in strength and performance as compared with rivets.

Bolts made of mild steel had been used occasionally in the early days of steel and cast iron structures. The first suggestion that high-strength bolts could be used appears to have come from Batho and Bateman in a report made to the Steel Structures Committee of Scientific and Industrial Research of Great Britain [3] in 1934. Their finding was that bolts having a yield strength of at least 54 ksi could be pretensioned sufficiently to prevent slip of connected material. Other early research was done at the University of Illinois by Wilson and Thomas [4]. This study, directed toward the fatigue strength of riveted shear splices, showed that pretensioned high-strength bolted joints had a fatigue life at least as good as that of the riveted joints.

In 1947, the Research Council on Riveted and Bolted Structural Joints (RCRBSJ) was formed. This body was responsible for directing the research that ultimately led to the wide-spread acceptance of the high-strength bolt as the preferred mechanical fastener for fabricated structural steel. The Council continues today, and the organization is now known as the Research Council on Structural Connections (RCSC). The first specification for structural joints was issued by the RCRBSJ in 1951 [5].

At about the same time as this work was going on in North America, research studies and preparation of specifications started elsewhere, first in Germany and Britain, then in other European countries, in Japan, and elsewhere. Today, researchers in many countries of the world add to the knowledge base for structural joints made using high-strength bolts. Interested readers can find further information on these developments in References [6, 7, 8, 9].

1.3. Mechanical Fasteners

The mechanical fasteners most often used in structural steelwork are rivets and bolts. On occasion, other types of mechanical fasteners are used: generally, these are special forms of high-strength bolts. Rivets and bolts are used in drilled, punched, or flame-cut holes to fasten the parts to be connected. Pretension may be present in the fastener.

Whether pretension is required is a reflection of the type and purpose of the connection.

Rivets are made of bar stock and are supplied with a preformed head on one end. The manufacturing process can be done either by cold or hot forming. Usually, a button-type head is provided, although flattened or countersunk heads can be supplied when clearance is a problem. In order to install the rivet, it is heated to a high temperature, placed in the hole, and then the other head is formed using a pneumatic hammer. The preformed head must be held in place with a backing tool during this operation. In the usual application, the second head is also a button head.

As the heated rivet cools, it shrinks against the gripped material. The result of this tensile strain in the rivet is a corresponding tensile force, the *pretension*. Since the initial temperature of the rivet and the initial compactness of the gripped material are both variable items, the amount of pretension in the rivet is also variable. Destructive inspection after a rivet has been driven shows that usually the rivet does not completely fill the barrel of the hole.

The riveting operation requires a crew of three or four and a considerable amount of equipment—for heating the rivets and for forming the heads—and it is a noisy operation.

taken from the parent rivet or bolt.) Since the only reason for dealing with rivet strength today is in the evaluation of an existing structure, care must be taken to ascertain the grade of the rivets in the structure. Very old structures might have rivet steel of lesser strength than that reflected by ASTM A502. (This ASTM standard, A502, was discontinued in 1999.)

In fabricated structural steel applications, threaded elements are encountered as tension rods, anchor rods, and structural bolts. In light construction, tension members are often made of a single rod, threaded for a short distance at each end. A nut is used to effect the load transfer from the rod to the next component. The weakest part of the assembly is the threaded portion, and design is based on the so-called "stress area." The stress area is a defined area, somewhere between the cross-sectional area through the root of the threads and the cross-sectional area corresponding to the nominal bolt diameter. In the US Customary system of units, this stress area (A_{st}) is calculated as—

$$A_{st} = 0.7854 \left(D - \frac{0.9743}{n} \right)^2 \quad (1.1)$$

where D is the bolt diameter, inches, and n is the number of threads per inch.

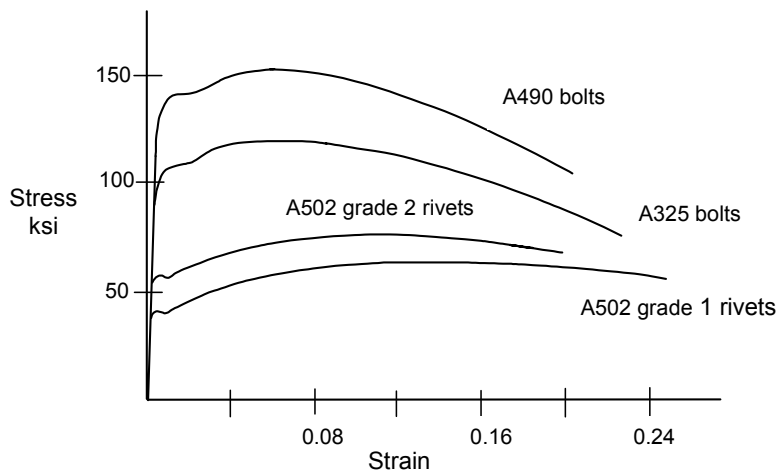

Fig. 1.1 Stress vs. Strain of Coupons taken from Bolts and Rivets

The ASTM specification for structural rivets, A502, provided three grades, 1, 2, and 3 [10]. Grade 1 is a carbon steel rivet for general structural purposes, Grade 2 is for use with higher strength steels, and Grade 3 is similar to Grade 2 but has atmospheric corrosion resistant properties. The only mechanical property specified for rivets is hardness. The stress vs. strain relationship for the two different strength levels is shown in Fig. 1.1, along with those of bolt grades to be discussed later. (The plot shown in Fig. 1.1 represents the response of a coupon

Threaded rods are not a factory-produced item, as is the case for bolts. As such, a threaded rod can be made of any available steel grade suitable for the job.

Anchor rods are used to connect a column or beam base plate to the foundation. Like tension members, they are manufactured for the specific task at hand. If hooked or headed, only one end is threaded since the main portion of the anchor rod will be bonded or secured mechanically into the concrete of the foundation. Alternatively, anchor rods can be threaded at both ends

and a nut used to develop the anchorage. Like threaded rods, anchor rods can be made of any grade of steel. One choice, however, is to use steel meeting ASTM A307, which is a steel used for bolts, studs, and other products of circular cross-section.¹ It is discussed below.

Structural bolts are loosely classified as either *common* or *high-strength*. Common bolts, also known as unfinished, ordinary, machine, or rough bolts, are covered by ASTM Specification A307 [11]. This specification includes the products known as *studs* and anchor bolts. (The term *stud* is intended to apply to a threaded product that will be used without a nut. It will be screwed directly into a component part.) Three grades are available in ASTM A307—A, B, and C. Grade B is designated for use in piping systems and will not be discussed here. Grade A has a minimum tensile strength of 60 ksi, and is intended for general applications. It is available in diameters from ¼ in. to 1½ in. Grade C is intended for structural anchorage purposes, i.e., non-headed anchor rods or studs. The diameter in this grade can be as large as 4 in. Structural bolts meeting ASTM A307 are sometimes used

Two strength grades of high-strength steel bolts are used in fabricated structural steel construction. These are ASTM A325 [12] and ASTM A490 [13]. Structural bolts manufactured according to ASTM A325 can be supplied as Type 1 or Type 3 and are available in diameters from ½ in. to 1½ in. (Type 2 bolts did exist at one time but have been withdrawn from the current specification.) Type 1 bolts use medium carbon, carbon boron, or medium carbon alloy steel. Type 3 bolts are made of weathering steel and their usual application is in structures that are also of weathering steel. A325 bolts are intended for use in structural connections that are assembled in accordance with the requirements of the Research Council on Structural Connections Specification (RCSC) [14]. This link between the product specification (ASTM A325) and the use specification (RCSC) is explicitly stated in the ASTM A325 Specification. The minimum tensile strength of A325 bolts is 120 ksi for diameters up to and including 1 in. and is 105 ksi for diameters beyond that value.²

The other high-strength fastener for use in fabricated

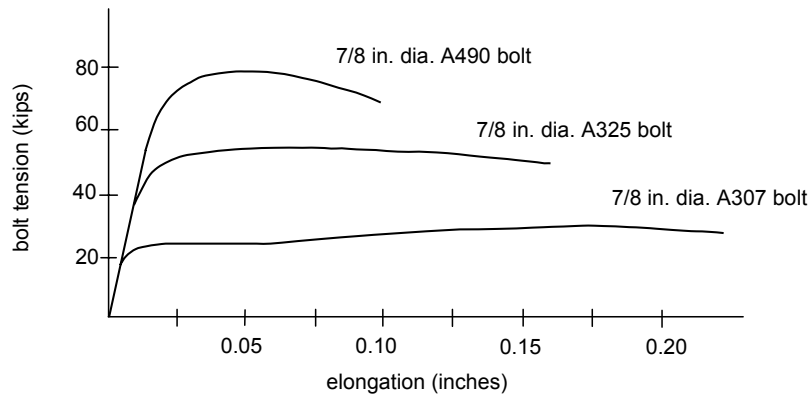

Fig. 1.2 Comparison of Bolt Types: Direct Tension

in structural applications when the forces to be transferred are not particularly large and when the loads are not vibratory, repetitive, or subject to load reversal. These bolts are relatively inexpensive and are easily installed. The response of an ASTM A307 bolt in direct tension is shown in Fig. 1.2, where it is compared with the two types of high-strength bolts used in structural practice. The main disadvantages of A307 bolts are its inferior strength properties as compared with high-strength bolts and the fact that the pretension (if needed for the type of joint) will be low and uncertain.

structural steel is that corresponding to ASTM A490. This fastener is a heat-treated steel bolt of 150 ksi minimum tensile strength (and maximum tensile strength of 170 ksi). As with the A325 bolt, it is intended that A490 bolts be used in structural joints that are made under the RCSC Specification. Two grades are available, Type 1 and Type 3. (As was the case with A325 bolts, Type 2 A490 bolts were available in the past, but they are no longer manufactured.) Type 1, available in diameters of ½ to 1½ in., is made of alloy steel. Type 3 bolts are atmospheric corrosion resistant bolts and are intended for

¹ ASTM F1554 –99 (Standard Specification for Anchor Bolts, Steel, 36, 55, and 105-ksi Yield Strength) is probably a more common choice today, however.

² The distinction of strength with respect to diameter arose from metallurgical considerations. These metallurgical restrictions no longer exist, but the distinction remains.

use in comparable atmospheric corrosion resistant steel components. They also can be supplied in diameters from ½ to 1½ in.

Both A325 and A490 bolts can be installed in such a way that a large pretension exists in the bolt. As will be seen, the presence of the pretension is a factor in some types of joints. This feature, and the concomitant requirements for installation and inspection, are discussed later.

There are a number of other structural fasteners covered by ASTM specifications, for example A193, A354, and A449. The first of these is a high-strength bolt for use at elevated temperatures. The A354 bolt has strength properties similar to that of the A490 bolt, especially in its Grade BD, but can be obtained in larger diameters (up to 4 in.) than the A490 bolt. The A449 bolt has strength properties similar to that of the A325 bolt, but it also can be furnished in larger diameters.³ It is often the specification used for high-strength anchor rods. Overall, however, A325, and A490 bolts are used in the great majority of cases for joining structural steel elements.

bolt and the nut has been satisfied, the main attribute of the nut is that it have a strength consistent with that of the bolt. Principally, this means that the nut must be strong enough and have a thread engagement deep enough so that it can develop the strength of the bolt before the nut threads strip.⁴ For the structural engineer, the selection of a suitable nut for the intended bolt can be made with the assistance of ASTM A563, Standard Specification for Carbon and Alloy Steel Nuts [15]. A table showing nuts suitable for various grades of fasteners is provided in that Specification. Washers are described in ASTM F436 [16]. The RCSC Specification [14] provides summary information for both nut and washer selection.

1.4. Types of Connections

It is convenient to classify mechanically fastened joints according to the types of forces that are produced in the fasteners. These conditions are tension, shear, and combined tension and shear. In each case, the force can be induced in several different ways.

Figure 1.3 shows a number of different types of joints that will produce shear in the fasteners. Part (a)

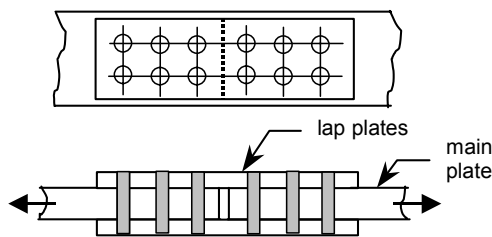

Fig. 1.3(a) Lap Splice

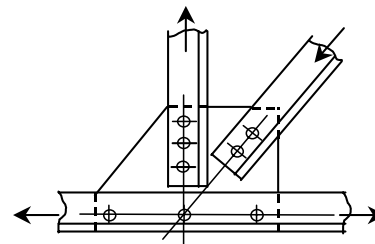

Fig. 1.3(b) Truss Joint

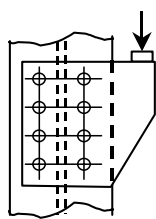

Fig. 1.3(c) Eccentric Joint

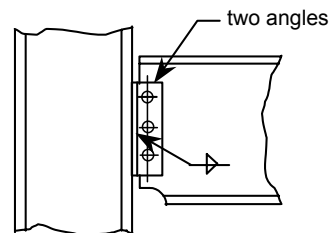

Fig. 1.3(d) Standard Beam Connection

Fig. 1.3 Bolted Joint Configurations

The nuts that accompany the bolts (and washers, if required) are an integral part of the bolt assembly. Assuming that the appropriate mechanical fit between the

³ Although the A354 and the A449 bolts have strength properties similar to the A325 and A490 bolts respectively, the thread length, quality assurance requirements, and packaging differ.

shows a *double lap* splice. The force in one main component, say the left-hand plate, must be transferred

⁴ Strictly speaking, this is not always required. If the only function of the bolt is to transfer shear, then the nut only needs to keep the bolt physically in place. However, for simplicity, the nut requirement described is applied to all bolting applications.

into the other main component, the right-hand plate. In the joint illustrated, this is done first by transferring the force in the left-hand main plate into the six bolts shown on the left-hand side of the splice. These bolts act in shear. Next, these six bolts transfer the load into the two splice plates. This transfer is accomplished by the bearing of the bolts against the sides of the holes in the plates.⁵ Now the load is in the splice plates, where it is resisted by a tensile force in the plate. Next, the load is transferred out of the splice plates by means of the six bolts shown on the right-hand side of the splice and into the main plate on the right-hand side. In any connection, understanding the flow of forces is essential for proper design of the

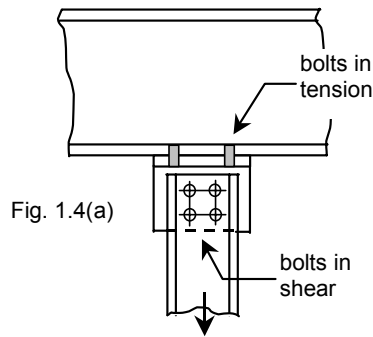

A joint in which tension will be induced in some of the fasteners is shown in Fig. 1.4 (a). This is the connection of a hanger to the lower flange of a beam. Figure 1.4 (b) shows a beam-to-column connection in which it is desired that both shear and moment be transmitted from the beam to the column. A satisfactory assumption for design is that all the shear force in the beam is in the web and all the beam moment is in the flanges. Accordingly, the fasteners in the pair of clip angles used to transfer the beam shear force are themselves loaded in shear. The beam moment (represented by a force couple located at the level of the flanges) is transmitted by the short tee sections that are

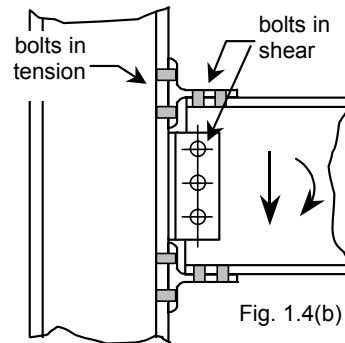

Fig. 1.4 Examples of Bolts in Tension

components, both the connected material and the fasteners. In the illustration, this visualization of the force flow (or, use of free-body diagrams!) allows the designer to see, among other things, that six fasteners must carry the total force at any given time, not twelve. More complicated arrangements of splice plates and use of different main components, say, rolled shapes instead of plates, are used in many practical applications. The problem for the designer remains the same, however—to understand the flow of forces through the joint.

Part (b) of Fig. 1.3 shows a panel point connection in a light truss. The forces pass out of (or into) the members and into (or out of) the gusset plate by means of the fasteners. These fasteners will be loaded in shear. Fig. 1.3 (c) shows a crane rail bracket. The fasteners again will be subjected to shear, this time by a force that is eccentric relative to the center of gravity of the fastener group. The standard beam connection (Fig. 1.3 (d)) provides another illustration of fasteners that will be loaded in shear. There are numerous other joint configurations that will result in shear in the fasteners.

fastened to the beam flanges. The connection of the tee section to the beam flanges puts those fasteners into shear, but the connection of the top beam flange tee to the

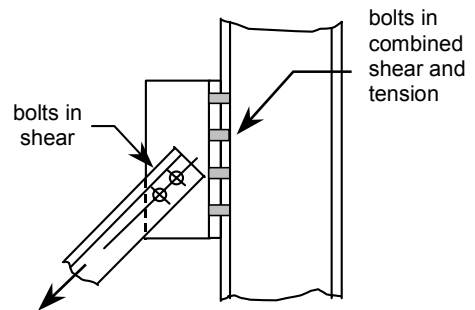

Fig. 1.5 Bolts in Combined Shear and Tension

column flange puts those fasteners into tension.

Finally, one illustration is presented where both shear and tension will be present in the fasteners. The inclined bracing member depicted in Fig. 1.5, shown as a pair of angles, is a two-force member. Considering the tension case, resolution of the inclined tensile force into its horizontal and vertical components identifies that the fasteners that connect the tee to the column must resist the applied forces in both shear and in tension.

⁵ Load transfer can also be by friction. This is discussed in Section 5.2.

The example of load transfer that was demonstrated by Fig. 1.3 (a) can be taken one step further, as is necessary to establish the forces and corresponding stresses in the connected material. Figure 1.6 shows the same joint that was illustrated in Fig. 1.3 (a), except that it has been simplified to one bolt and two plates. Part (a) shows the joint. A free-body diagram obtained when the bolt is cut at the interface between the two plates is shown in Fig. 1.6 (b). (A short extension of the bolt is shown for convenience.) For equilibrium, the force in the plate, P , must be balanced by a force in the bolt, as shown. This is the shear force in the bolt. If necessary, it can be expressed in terms of the average shear stress, τ , in the bolt by dividing by the cross-sectional area of the bolt. Going one step further, the bolt segment is isolated in Fig. 1.6 (c). This free-body diagram shows that, in order to equilibrate the shear force in the bolt, an equal and opposite force is required. The only place this can exist is on the right-hand face of the bolt. This force is delivered to the bolt as the top plate pulls up against the bolt, i.e., the bolt and the plate bear against one another. Finally, the short portion of the top plate to the right of the bolt, Fig. 1.6 (a), is shown in Fig. 1.6 (d). The force identified as a "bearing force" in Fig. 1.6 (c) must be present as an equal and opposite force on the plate in part (d) of the figure. This bearing force in the plate can be expressed as

a stress, as shown, if that is more convenient. Finally, since the plate segment must be in equilibrium, the pair of forces, $P/2$, must be present in the plate.

These are simple illustrations of how some connections act and the forces that can be present in the bolts and in the adjacent connected material. There are some other cases in which the load transfer mechanism needs to be further explained, for example, when pretensioned high-strength bolts are used. This will be done in later chapters.

1.5. Design Philosophy

For fabricated steel structures, two design philosophies coexist at the present time in the United States—limit states design and allowable stress design. In limit states design, commonly designated in the United States as Load and Resistance Factor Design, it is required that the "limit states" of performance be identified and compared with the effect of the loads applied to the structure. The limit states are considered to be *strength* and *serviceability*.

In the United States, the most commonly used specifications for the design of steel buildings are those of the American Institute of Steel Construction. In limit states design format, the AISC Load and Resistance Factor Design Specification (LRFD) is used [17]. If

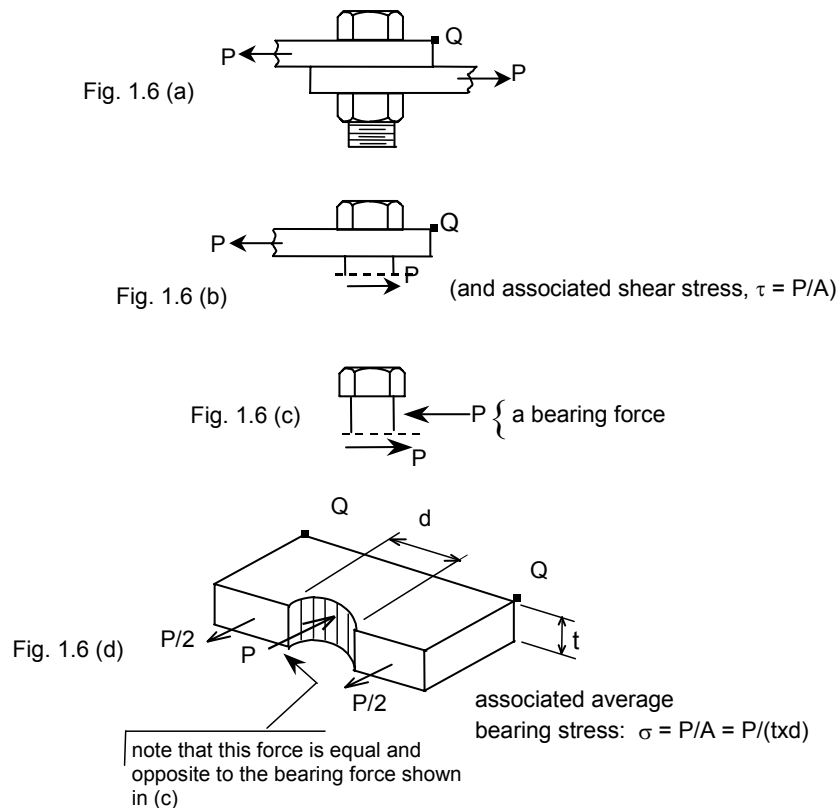

Fig.1.6 Bolt Forces and Bearing in Plate

allowable stress design (ASD) is used, then the AISC Specification for Structural Steel Buildings, Allowable Stress Design and Plastic Design, is available [18].

An example of a strength limit state is the compression buckling strength of an axially loaded column. The design strength is calculated according to the best available information, usually as expressed by a Specification statement of the nominal strength, which is then reduced by a *resistance factor*. The resistance factor, ϕ , is intended to account for uncertainties in the calculation of the strength, understrength of material, level of workmanship, and so on. In LRFD terminology, the product of the calculated ultimate capacity and the resistance factor is known as the *design strength*.

The loads that act on the structure are likewise subject to adjustment: few, if any, loads are deterministic. Therefore, the expected loads on a structure are also multiplied by a factor, the *load factor*. (More generally, load factors are applied in defined combinations to different components of the loading.) For most applications, the load factor is greater than unity. Finally, the factored resistance is compared with the effect of the factored loads that act on the structure.

In allowable stress design, the structure is analyzed for the loads expected to be acting (*nominal loads*) and then stresses calculated for each component. The calculated stress is then compared with some permissible stress. For example, a fraction of the yield stress of the material is used in the case of a tension member.

It is interesting to note that, for a long time, the design of mechanical fasteners has been carried out using a limit states approach. Even under allowable stress design, the permissible stress was simply a fraction of the tensile strength of the fastener, not a fraction of the yield strength. Indeed, it will be seen that there is no well-defined yield strength of a mechanical fastener: the only logical basis upon which to design a bolt is its ultimate strength.

The other limit state that must be examined is serviceability. For buildings, this means that such things as deflections, drift, floor vibrations, and connection slip may have to be examined. In contrast to the situation when the ultimate limit state is under scrutiny, these features are to be checked under the nominal loads, not the factored loads.

One of the most important features of bridge design (and other structures subjected to moving or repetitive loads) is fatigue. Some specifications put this topic in the category of ultimate limit state, whereas others call it a serviceability limit state. The principal design specification for fatigue in highway bridges in the United States, the rules of the American Association of State Highway and Transportation Officials (AASHTO), creates a separate limit state for fatigue [19]. This is done primarily because the so-called *fatigue truck*, used to

calculate stresses for the fatigue case, does not correspond to either the nominal load or to the usual factored load.

A full discussion of allowable stress design and limit states design can be found in most books on the design of fabricated steel structures. See, for example, Reference [20].

1.6. Approach Taken in this Primer

In this document, the usual approach is to describe the phenomenon under discussion in general terms, provide enough background information by way of research or, in some cases, theoretical findings, to enable a description of the phenomenon to be made, and then to provide a design rule. This is then linked to the corresponding rule in the principal specification, that of AISC [17], and only the LRFD rules will be discussed. In a few cases, the reference specification will be that of AASHTO [19].

Chapter 2

STATIC STRENGTH of RIVETS

2.1 Introduction

As discussed in Chapter 1, rivets have not been used in the fabrication and erection of structural steel for many years. However, there are still reasons why a structural engineer may need to know about the behavior of rivets. Because they can be present in existing buildings and bridges, it follows that one objective is the necessity of evaluating the strength of these elements when a structure is considered for such things as renovation or the determination of safety under increased load levels. In this Chapter, the static design strength of rivets is examined. The fatigue strength of a riveted connection, the other major area of interest, is more logically treated in Chapter 7, Fatigue of Bolted and Riveted Joints.

2.2 Rivets Subject to Tension

The tensile stress vs. strain response for ASTM A502 rivet steel (i.e., undriven rivets) was shown in Fig. 1.1. The tensile strength is about 60 ksi for Grade 1 and about 80 ksi for Grade 2 or 3. After the rivet has been driven, the tensile strength can be significantly increased [21]. At the same time, however, the ductility of the driven rivet is considerably less than that of the material from which it was driven. Most tension tests of driven rivets also show a decrease in strength with increasing rivet length (grip). The residual clamping force that is present in a driven rivet does not affect the ultimate strength of the rivet. In principle then, the design tensile strength of a rivet is simply the product of the minimum tensile strength of the rivet material multiplied by a resistance factor.

The AISC LRFD Specification provides rules for the design tension strength (ϕR_n) of ASTM A502 rivets. In accordance with Article J3.6 of the Specification, this is to be calculated as:

$$\phi R_n = \phi F_t A_b \quad (2.1)$$

where ϕR_n = design tension strength in tension, kips

ϕ = resistance factor, taken as 0.75

F_t = nominal tensile strength, taken as 45 ksi for ASTM A502 Grade 1 hot-driven rivets or as 60 ksi for Grade 2 hot-driven rivets

A_b = cross-sectional area of the rivet according to its nominal diameter, in.²

The product $F_t A_b$ obviously is the ultimate tensile strength (nominal strength) of the rivet shank. The value of the resistance factor ϕ recommended in the AISC Specification, 0.75, is relatively low, as it is for most connection elements. There is no research available that identifies the appropriate value of the resistance factor, ϕ , for rivets in tension. However, the case of high-strength bolts in tension can be used as a basis of comparison. In Reference [22], it was established that $\phi = 0.85$ is a satisfactory choice for high-strength bolts in tension. This is also the value recommended in the *Guide* [6]. Thus, selection of the value 0.75 is a conservative choice for rivets, but it results in values that are consistent with those used historically in allowable stress design.

It is not uncommon for mechanical fasteners acting in tension to be loaded to a level that is greater than that corresponding to the total applied load divided by the number of fasteners. This is the result of prying action produced by deformation of the connected parts. It is advisable to follow the same rules for prying action in the case of rivets in tension as are recommended for bolts in tension. Prying action is discussed in Chapter 6.

The most common need for the strength calculation of a rivet or rivet group in tension will be to determine the strength of an existing connection. The integrity of the rivet heads should be closely examined. If the head is not capable of resisting the force identified in Eq. 2.1, then the calculation simply is not valid. Rivet heads in such structures as railroad bridges can be severely corroded as a result of the environmental conditions to which they have been subjected over the years.

2.3 Rivets in Shear

Numerous tests have been carried out to determine the shear strength of rivets—see, for example, References [21, 23, 24]. These tests all show that the relationship between the shearing force that acts on a rivet and its corresponding shearing displacement has little, if any, region that can be described as linear. Thus, the best description of the strength of a rivet in shear is its ultimate shear capacity. In order to be able to compare rivets of different basic strengths, it is usual to relate the shear strength to the tensile strength of the steel from which the rivet is made. The results [21, 23] indicate that the value of this ratio (shear strength / tensile strength) is about 0.75, and that the ratio is not significantly affected by the grade of rivet or whether the shear test was done

on driven or undriven rivets. However, there is a relatively wide spread in the value of the ratio, from about 0.67 to 0.83, according to the work in References [21 and 23].

Typical shear load vs. shear deformation tests are shown in Fig. 2.1 [25]. These tests are for 7/8 in. dia. A502 Grade 1 rivets with two different grip lengths, 3 in. and 4½ in. Because of greater bending in the longer rivets (and un-symmetrical loading in the case of these tests), there was greater deformation in these rivets in the early stages of the test. However, the ultimate shear strength was unaffected by grip length. Since driving of the rivet increases its tensile strength, the corresponding shear strength is likewise expected to increase. Thus, the shear strength of Grade 1 A502 rivets can be expected to be at least $0.75 \times 60 \text{ ksi} = 45 \text{ ksi}$ and that for Grade 2 or Grade 3 rivets will be about $0.75 \times 80 \text{ ksi} = 60 \text{ ksi}$. (The multiplier 0.75 is not a resistance factor. It is the value of the ratio shear strength / tensile strength mentioned above.)

As was the case for rivets in tension, there have not been any studies that have explored the resistance factor for rivets in shear. The value recommended in the *Guide* [6] for bolts in shear is 0.80. In Reference [22], the resistance factor recommended is 0.83 for ASTM A325 bolts and 0.78 for ASTM A490 bolts.

In the AISC LRFD Specification, Section J3.6 requires that the design shear strength (ϕR_n) of a rivet is to be taken as—

$$\phi R_n = \phi F_v A_b \quad (2.2)$$

where ϕR_n = design shear strength, kips

ϕ = resistance factor, taken as 0.75

F_v = nominal shear strength, taken as 25 ksi for ASTM A502 Grade 1 rivets or as 33 ksi for Grade 2 and Grade 3 hot-driven rivets

A_b = cross-sectional area of the rivet, in.² The calculation of A_b should reflect the number of shear planes present.

Comparing the nominal shear strength values given in the Specification for the two rivet grades (25 ksi or 33 ksi) with the corresponding experimentally determined values (45 ksi or 60 ksi), it can be seen that the permissible values under the AISC LRFD rules are significantly conservative. When evaluating the shear strength of rivets in an existing structure, these conservative elements of the design rule can be kept in mind.

The effect of joint length upon shear strength applied to bolted shear splices (Section 5.1.) should also be

applied for long riveted connections. See also Section J3.6 of the AISC LRFD Specification.

2.4 Rivets in Combined Shear and Tension

It was explained in Section 1.4 (and with reference to Fig. 1.5) that fasteners must sometimes act under a combination of tension and shear. Tests done by Munse and Cox [23] form the basis for the design rule for this case. The tests were done on ASTM A141 rivets (which are comparable to A502 Grade 1 rivets), but the results are considered to be reasonable for application to all grades of rivets. The test variables included variation in grip length, rivet diameter, driving procedure, and manufacturing process [23]. The only one of these

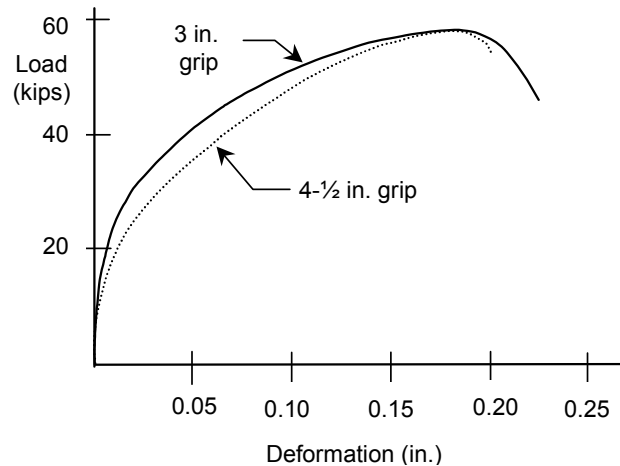

Fig. 2.1 Shear vs. Deformation Response of A502 Grade 1 Rivets

variables that had an influence on the behavior was grip length: long grip rivets tended to show a decrease in strength with length. This is consistent with tests done on rivets loaded in shear only. As the loading condition changed from tension-only to shear-only, deformation capacity decreased. This also is consistent with observations for rivets in tension and rivets in shear.

An elliptical interaction curve was fitted to the test results [23]. The mathematical description of the curve is:

$$\frac{x^2}{(0.75)^2} + y^2 = 1.0 \quad (2.3)$$

where x = ratio of calculated shear stress (τ) to tensile strength of the rivet (σ_u) (i.e., $x = \tau / \sigma_u$)

y = ratio of calculated tensile stress (σ) to tensile strength of the rivet (σ_u) (i.e., $y = \sigma / \sigma_u$)

An alternative representation of the test results was also suggested by the researchers [26]. This form, which

approximates the elliptical interaction equation with three straight lines, is the model used in the AISC LRFD Specification. In the AISC Specification (Table J3.5), A502 rivets of Grade 1 are permitted a nominal tension stress (ksi) under conditions of combined tension and shear of

$$F_t = 59 - 2.4 f_v \leq 45 \quad (2.4)$$

and for A502 Grade 2 and 3 rivets, the expression is:

$$F_t = 78 - 2.4 f_v \leq 60 \quad (2.5)$$

Equations 2.4 and 2.5 use the AISC LRFD notation for stresses. The resistance factor $\phi = 0.75$ must be applied to the result obtained by Equation 2.4 or 2.5, and then the design tension strength of the rivet (now reduced by the presence of shear) can be determined using Equation 2.1.

In applying these rules, it is apparent that the nominal tensile stress is limited to the nominal tensile strength of the rivet, which is 45 ksi for Grade 1 and 60 ksi for Grade 2 and 3. It should be remembered, as well, that there is also a limit on the calculated shear stress, f_v (computed under the factored loads). It must be equal to or less than the nominal shear strength multiplied by the resistance factor. The nominal shear stress is 25 ksi for A502 Grade 1 rivets and 33 ksi for Grade 2 and 3 rivets.

An advantage of the straight-line representation is that it identifies the range of shear stress values for which a reduction in tensile strength needs to be made. For example, a reduction in tensile strength for Grade 1 rivets is required when the calculated shear stress under the factored loads is between 5.8 ksi and the maximum permitted value of 18.8 ksi (i.e., $25 \text{ ksi} \times \phi = 0.75$). At the former, the nominal tensile stress is, of course, 45 ksi, and at the latter it has been reduced to 21.5 ksi.

The elliptical representation and the straight-line representation fit the test data about equally well when the forms presented in Reference [26] are applied. In the formulation used by AISC (Equations 2.4 and 2.5 above), the result will be conservative. It has already been pointed out in this Chapter that the rules given in the AISC LRFD Specification for the tension-only and the shear-only cases are themselves conservative.

Chapter 3

INSTALLATION OF BOLTS AND THEIR INSPECTION

3.1 Introduction

The installation of bolts, both high-strength bolts and common bolts, is presented in this chapter. This is accompanied by information on the inspection process that is necessary to ensure that the expectations of the installation have been met. Further information on the physical characteristics and mechanical properties of bolts is also included.

High-strength bolts can be installed in a way such that an initial pretension (or, preload) is present. The installation of ordinary bolts (ASTM A307) does not result in any significant pretension. For some applications, the presence of a pretension affects how the joint performs, and the inspection of installation of high-strength bolts should reflect whether or not bolt pretension is required. Whether bolts should be pretensioned is important in both the installation and inspection processes. Because of this importance, advice is given as to when pretensioned bolts should be required.

3.2 Installation of High-Strength Bolts

A bolt is a headed externally threaded fastener, and it is intended to be used with a nut. High-strength bolts were introduced in Section 1.3, and for structural applications two types of bolts are used—ASTM A325 and ASTM A490. Washers may or may not be required (see Chapter 8), depending on the application. Both the bolt head and the nut are hexagonal. The shank is only partially threaded, and the threaded length depends on the bolt diameter. Complete information on these details can be obtained in the relevant specifications [12, 13].

Not all structural bolts used in practice precisely meet the definition just given. Two other bolt configurations are in common use. These are bolts that meet or replicate the ASTM A325 or A490 requirements, but which have special features that relate to their installation. One is the "twist-off" bolt, which is covered by ASTM Specification F1852. It is described in Section 3.2.4. The other case is different from the conventional bolt–nut set only by the addition of a special washer that acts as an indicator of the pretension in the bolt. Its installation and other characteristics are described in Section 3.2.5.

Bolts meeting the requirements of ASTM Standards A325 and A490 were first described in Section 1.3. It was noted there that the ultimate tensile strength level for A325 bolts is 120 ksi or 105 ksi. The former applies to bolts of diameter up to and including 1 in. and the latter for bolts greater than 1 in. diameter. There is no maximum ultimate tensile strength specified for A325 bolts. The other kind of high-strength bolt used in

structural practice, ASTM A490, has a specified ultimate tensile strength of 150 ksi (and a maximum tensile strength of 170 ksi) for all diameters. In each case, the mechanical requirements of the specifications also make reference to a so-called proof load. This is the level up to which the bolt can be loaded and then unloaded without permanent residual deformation. In mild structural steels, this is termed the yield strength. However, in the case of the high-strength bolts there is no well-defined yield strength and all the design strength statements for high-strength bolts use the ultimate tensile strength as the basic parameter. Hence, the designer need not be concerned about the proof load.

It is required that the nuts for high-strength bolts used in normal structural applications are heavy hex nuts that conform to the requirements of ASTM Standard A563 [15]. (If the bolts are to be used in high-temperature or high-pressure applications, then another ASTM Standard is used for identifying the appropriate nuts.) When zinc-coated A325 bolts are to be used, then the nuts must also be galvanized and tapped oversize. In this case, requirements for lubrication of the nuts and a rotation capacity test for the bolt–nut assembly are specified in ASTM Standard A325. (This is discussed in Section 8.5.)

Bolts are installed by first placing them in their holes and then running the nut down on the bolt thread until it contacts the connected plies. This can be done either manually, by using a spud wrench,¹ or using a power tool, which is usually a pneumatic impact wrench. The expectation is that the connected parts will be in close contact, although in large joints involving thick material it cannot be expected that contact is necessarily attained completely throughout the joint. The installation process should start at the stiffest part of the joint and then progress systematically. Some repetition may be required. The condition of the bolts at this time is referred to as *snug-tight*, and it is attained by the full effort of the ironworker using a spud wrench or by running the nut down until the air-operated wrench first starts to impact. The bolt will undergo some elongation during this process, and there will be a resultant tensile force developed in the bolt. In order to maintain equilibrium, an equal and opposite compressive force is developed in the connected material. The amount of the bolt tension at the

¹ A spud wrench is the tool used by an ironworker to install a bolt. It has an open hexagonal head and a tapered handle that allows the worker to insert it into holes for purposes of initial alignment of parts.

snug-tightened condition is generally large enough to hold the parts compactly together and to prevent the nut from backing off under static loads. As an example, in laboratory tests snug-tight bolt pretensions range from about 5 to 10 kips for 7/8 in. diameter A325 bolts. In practice, the range is probably even larger.

For many applications, the condition of snug-tight is all that is required. Because use of snug-tightened bolts is an economical solution, they should be specified whenever possible. If the function of the joint requires that the bolts be pretensioned, then bolt installation must be carried out in one of the ways described following. Whether or not the bolts need to be pretensioned is described in Section 3.3.

3.2.1 Turn-of-Nut Installation

If the nut continues to be turned past the location described as snug-tight, then the bolt tension will continue to increase. In this section, the installation process described is that in which a prescribed amount of turn of the nut is applied. This is an elongation method of controlling bolt tension. Alternatively, a prescribed and calibrated amount of torque can be applied, as described in Section 3.2.2.

As the nut is turned, conditions throughout the bolt are initially elastic, but local yielding in the threaded portion soon begins. Most of the yielding takes place in the region between the underside of the nut and the thread run-out. As the bolt continues to elongate under the action of turning the nut, the bolt load (pretension) vs. elongation response flattens out, that is, the bolt pretension force levels off.

Figure 3.1 shows the bolt pretension obtained by turning the nut on a certain lot of A325 bolts [27]. These were 7/8 in. diameter bolts that used a grip length of 4–1/8 in. (In this laboratory study, the snug-tight condition was uniquely established for all bolts in the lot by setting

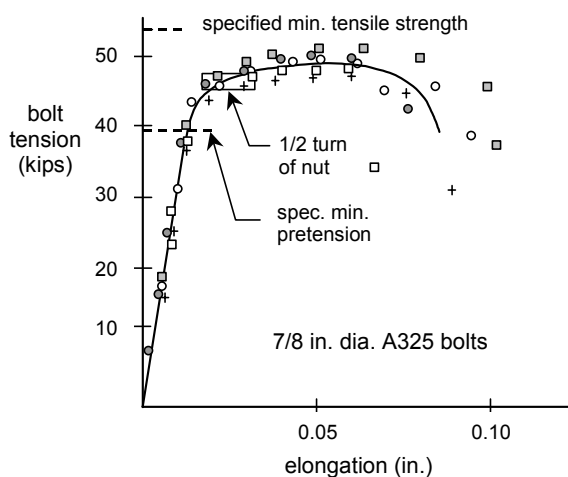

Fig. 3.1 Load vs. Elongation Relationship, Torqued Tension

the snug-tight load at 8 kips.) It can be seen that the average response is linear up to a load level slightly exceeding the specified proof load, then yielding starts to occur in the threads and the response curve flattens out. Also shown in the figure is the range of elongations that were observed at 1/2 turn past snug, which is the RCSC Specification requirement [14] for bolts of the length used in this study. The specified minimum bolt pretension is 39 kips for A325 bolts of this diameter, and it can be observed that the measured pretension at 1/2 turn is well above this value. (The minimum bolt pretension required is 70% of the minimum specified ultimate tensile strength of the bolt [14].)

Figure 3.1 also shows that the specified minimum tensile strength of the bolt (i.e., direct tension) is well above the maximum bolt tension reached in the test (i.e., torqued tension). This reflects the fact that during installation the bolts are acting under a condition of combined stresses, tension and torsion.

The results of the bolt installation shown in Fig. 3.1, which is typical of turn-of-nut installations, raise the following questions:

- How do such bolts act in joints, rather than individually as depicted in Fig. 3.1?
- If the bolts subsequently must act in tension, can they attain the specified minimum tensile strength?
- Does the yielding that takes place in the bolt threads (mainly) affect the subsequent strength of the bolt in shear, tension, or combined tension and shear?
- What is the margin against twist-off of the bolts in the event that more than 1/2 turn is applied inadvertently?
- How sensitive is the final condition (e.g., bolt pretension at 1/2 turn) to the level of the initial pretension at snug-tight?

The first three items in the list apply to bolts installed by any procedure: the others are specific to turn-of-nut installations.

Several of these questions can be addressed by looking at the behavior of bolts that were taken from the same lot as used to obtain Fig. 3.1 when they were installed in a large joint [6]. Figure 3.2 shows the bolt elongations and subsequent installed pretensions for 28 of these bolts installed to 1/2 turn of nut beyond snug-tight.

The individual bolt pretensions can be estimated by projecting upward from the bolt elongation histogram at the bottom of the figure to the plot of bolt pretensions obtained by the turn-of-nut installation. Even though there is a large variation in bolt elongation for these 28 bolts (from about 0.03 in. to nearly 0.05 in.), the resultant pretension hardly varies at all. This is because the bolts have entered the inelastic range of their response. Thus, the turn-of-nut installation results in a reliable level of

bolt pretension and one that is consistently above the minimum required bolt pretension.

The second thing that can be observed from Fig. 3.2 is that, even though the range of bolt pretension at the snug condition was large (from about 16 kips to 36 kips), the final pretension is not affected in any significant way. Again, this is because the bolt elongation imposed during the installation procedure has taken the fastener into the inelastic region of its behavior.

It is highly unlikely that a high-strength bolt, once installed, will be turned further than the prescribed installation turn. Because of the extremely high level of bolt pretension present, about 49 kips in the example of Fig. 3.2, it would require considerable equipment to overcome the torsional resistance present and further turn the nut. In other words, it would require a deliberate act to turn the nut further, and this is not likely to take place in either bridges or buildings once construction has been completed. It is possible, however, that an ironworker could inadvertently apply more than the prescribed turn. For instance, what is the consequence if a nut has been turned to, say, 1 turn rather than to 1/2 turn?

The answer to this question is twofold. First, at 1 turn of the nut the level of pretension in the bolt will still be above the specified minimum pretension [6]. In fact, the research shows that the pretension is likely to still be high just prior to twist-off of the fastener. Second, the margin against twist-off is large. Figure 3.3 shows how bolt pretension varies with the number of turns of the nut for two lots of bolts, A325 and A490, that were 7/8 in. diameter and 5-1/2 in. long and had 1/8 in. of thread in the grip [6]. The installation condition for this bolt length is 1/2 turn. It can be seen that it was not until about 1-3/4 turns that the A325 bolts failed and about 1-1/4 turns

when the A490 bolts failed. In other words, there is a considerable margin against twist-off for both fastener types.

It was observed in discussing the data in Fig. 3.1 that the pretension attained by the process of turning a nut onto a bolt does not reach the maximum load that can be attained in a direct tension test of the bolt. The presence of both tensile stresses and torsional stresses in the former case degrades the strength. However, laboratory tests for both A325 and A490 bolts [27, 28] show that a bolt installed by the turn-of-nut method and then subsequently loaded in direct tension only is able to attain its full direct tensile strength. This is because the torsional stresses introduced in the installation process are dissipated as the connected parts are loaded and the contact stresses decrease. Thus, bolts installed by turning on the nut against gripped material can be proportioned for subsequent direct tension loading on the basis of their ultimate tensile strength.

The strength of bolts in shear is likewise unaffected by the stresses imposed during installation. This is elaborated upon in the discussion in Section 4.3, where the strength of bolts in shear is described.

It will be seen in Section 4.4 that the design rule for the capacity of bolts in combined tension and shear is an interaction equation developed directly from test results. Hence, the question as to how the strength might be affected is not influenced by the pre-existing stress conditions. In any event, since neither the direct tensile strength nor the shear strength is affected by pretension, it is unlikely that the combined torsion and shear case is influenced.

The discussion so far has described bolts that are installed to 1/2 turn past snug. In practice, this will indeed

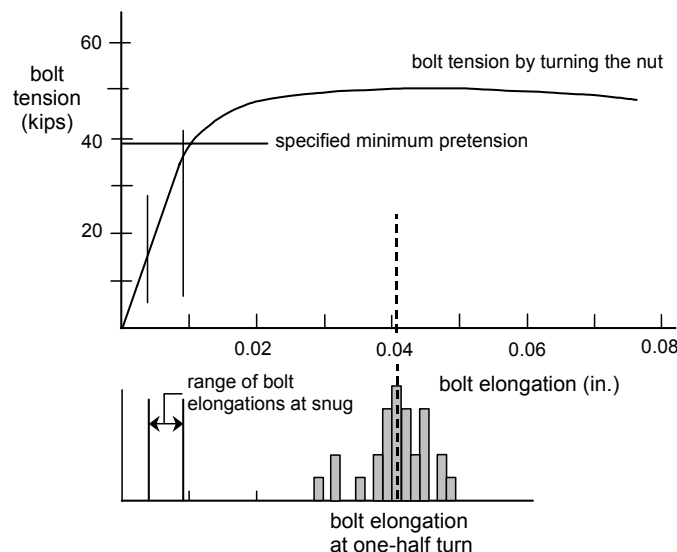

Fig. 3.2 Bolt Tension in Joint at Snug and at One-Half Turn of Nut

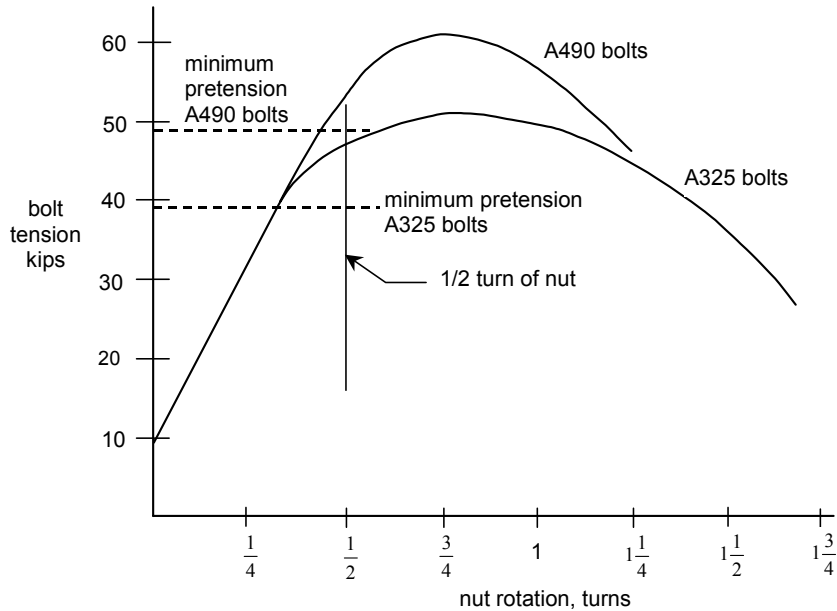

Fig. 3.3 Bolt Load vs. Nut Rotation

be the RCSC Specification requirement applicable in a great many practical cases. However, for longer bolts, 1/2 turn may not be sufficient to bring the pretension up to the desired level, whereas for shorter bolts 1/2 turn might twist off the bolt. Laboratory studies show that for bolts whose length is over eight diameters but not exceeding 12 diameters, 2/3 turn of the nut is required for a satisfactory installation. For short bolts, those whose length is up to and including four diameters, 1/3 turn of nut should be applied. The bolt length is taken as the distance from the underside of the bolt head to the extremity of the bolt. It is expected that the end of the bolt will either be flush with the outer face of the nut or project slightly beyond it. If the combination of bolt length and grip is such that there is a large "stick-through," then it is advisable to treat the bolt length as the distance from the underside of the bolt head to the outer face of the nut for the purpose of selecting the proper turn to be applied.

These rules apply when the outer faces of the bolted parts are normal to the axis of the bolts. Certain structural steel shapes have sloped surfaces—a slope up to 1:20 is permitted. When non-parallel surfaces are present, the amount of turn-of-nut differs from those cases just described. The exact amount to be applied depends upon whether one or both surfaces are sloped. The RCSC Specification should be consulted for these details. Alternatively, beveled washers can be used to adjust the surfaces to within a 1:20 slope, in which case the resultant surfaces are considered parallel.

It is important to appreciate that the connected material within the bolt grip must be entirely steel. If material more compressible than steel is present, for example if material for a thermal break were contemplated, then the turn-of-nut relationships

developed for solid steel do not apply. Whatever the bolt type and method of installation, the problems that can arise have to do with the attainment and retention of bolt pretension. The RCSC Specification simply takes the position that all connected material must be steel.

Users of bolts longer than about 12 bolt diameters should exercise caution: bolts of these lengths have not been subjected to very much laboratory investigation for turn-of-nut installation. The installation of such bolts should be preceded by calibration tests to establish the appropriate amount of turn of the nut.

Generally speaking, washers are not required for turn-of-nut installations. The main exceptions are (a) when non-parallel surfaces are present, as discussed above, (b) when slotted or oversized holes are present in outer plies, and (c) when A490 bolts are used to connect material having a specified yield strength less than 40 ksi. The use of slotted or oversized holes is discussed in Section 8.3. The necessity for washers when A490 bolts are used in lower strength steels arises because galling and indentation can occur as a result of the very high pretensions that will be present. If galling and indentation take place under the bolt head or nut, the resultant pretension can be less than expected. Use of hardened washers under both the bolt head and the nut will eliminate this problem. Further details are found in Chapter 8.

It should also be observed that any method of pretensioned installation, of which turn-of-nut is the only one discussed so far, can produce bolt pretensions greater than the specified minimum value. This is not a matter for concern. Those responsible for the installation of high-strength bolts and inspectors of the work should understand that attainment of the "exact" specified value

of pretension is not the goal and that exceeding the specified value is acceptable.

In summary, the use of the turn-of-nut method of installation is reliable and produces bolt pretensions that are consistently above the prescribed values.

3.2.2 Calibrated Wrench Installation

Theoretical analysis identifies that there is a relationship between the torque applied to a fastener and the resultant pretension [29]. It is therefore tempting to think that bolts can successfully be installed to specified pretensions by application of known amounts of torque. The relationship between pretension and torque is a complicated one, however, and it reflects such factors as the thread pitch, thread angle and other geometrical features of the bolt and nut, and the friction conditions between the various components of the assembly. As a consequence, it is generally agreed that derived torque vs. pretension relationships are unreliable [6, 29]. The RCSC Specification [14] is explicit upon this point. It states that, "This Specification does not recognize standard torques determined from tables or from formulas that are assumed to relate torque to tension."

There is a role for a torque-based installation method, however. Provided that the relationship between torque and resultant bolt pretension is established by calibration, then it becomes an acceptable method of installation. In the RCSC Specification, this is known as the *calibrated wrench* method of installation. What is required, then, is to calibrate the torque versus pretension process under conditions that include the controlling features described above. In practice, this means that an air-operated wrench² is used to install a representative sample of the fasteners to be used in a device capable of indicating the tension in the bolt as the torque is applied. Rather than trying to identify the torque value itself, the wrench is adjusted to stall at the torque corresponding to the desired preload. The load-indicating device used is generally a hydraulic load cell (one trade name, Skidmore–Wilhelm). The representative sample is to consist of three bolts from each lot, diameter, length, and grade of bolt to be installed on a given day. The target torque determined in this calibration procedure is required to produce a bolt pretension 5% greater than the specified minimum value given in the Specification. (The 5% increase is intended to provide a margin of confidence between the sample size tested and the actual installation of bolts in the work.) Manual torque wrenches can also be used, but the wrench size required means that this is not usually a practical procedure for structural steelwork. Finally, in order to minimize variations in the friction conditions between the

nut and the connected material, hardened washers must be used under the element being turned (usually the nut).

It is important to appreciate that if any of the conditions described change, then a new calibration must be carried out. It should be self-evident that the calibration process is a job-site operation, and not one carried out in a location remote from the particular conditions of installation.

The RCSC Specification [14] also requires that the pre-installation procedure described above be likewise used for turn-of-nut installations, except that it is not required on a daily basis. Strictly speaking, this is not an essential for the turn-of-nut method, as it is for calibrated wrench. However, it is useful for such things as discovering potential sources of problems such as overtapped galvanized nuts, nonconforming fastener assemblies, inadequate lubrication, and other similar problems.

3.2.3 Pretensions Obtained using Turn-of-Nut and Calibrated Wrench Methods

The installation methods described in Section 3.2.1 and 3.2.2 are for those situations where bolt pretension is required in order that the joint fulfill the intended purpose. (See Section 3.3.) Accordingly, it is appropriate to comment on the bolt pretensions actually obtained, as compared to the specified minimum values. As already mentioned, the specified minimum bolt pretension corresponds to 70% of the specified ultimate tensile strength. It has also been noted that the calibration procedure requires that the installation method be targeted at pretensions 5% greater than the specified minimum values.

It is not to be expected that the two methods will produce the same bolt pretension. The calibrated wrench method has a targeted value of pretension, whereas the turn-of-nut method simply imposes an elongation on the bolt. In the former case, bolts of greater than minimum strength will not deliver pretensions that reflect that condition, whereas turn-of-nut installations will produce pretensions that are consistent with the actual strength of the bolt. Figure 3.4 shows this diagrammatically. Two bolt lots of differing strength are illustrated. In the turn-of-nut method, where a given elongation (independent of bolt strength) is imposed, greater pretensions result for bolt lot A than for bolt lot B. On the other hand, use of the calibrated wrench method of installation produces the same bolt pretension for both lots because the calibration is targeted to a specific bolt pretension. It therefore does not reflect the differences in bolt strength.

Laboratory studies show that the actual bolt pretension obtained when turn-of-nut installation is used can be substantially greater than the value specified. This increase is the result of two factors. One is that production bolts are stronger than the minimum specified value. The

² Electric wrenches are also available and are particularly useful for smaller diameter bolts.

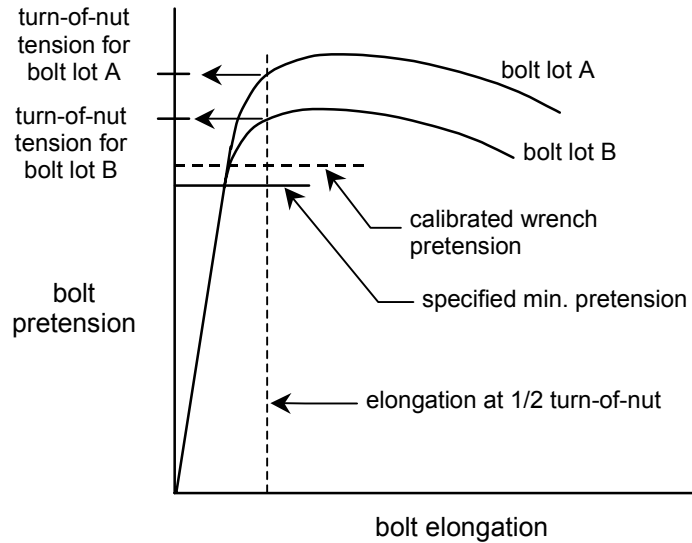

Fig. 3.4 Influence of Tightening Method on Bolt Tension

other factor is that turn-of-nut installation produces pretensions greater than the specified value regardless of the bolt strength. For example, in the case of A325 bolts, production bolts are about 18% stronger than their specified minimum tensile strength and turn-of-nut (1/2 turn) produces a pretension that is about 80% of the actual tensile strength [6]. It follows then that the installed bolt pretension will be about $(1.18 \times 0.80 =) 0.95$ times the specified minimum tensile strength of A325 bolts. In other words, the average actual bolt pretension is likely to exceed the minimum required value by about $[(0.95 - 0.70) / 0.70] 100\% = 35\%$ when turn-of-nut is used. A similar investigation of A490 bolts installed in laboratory conditions shows that the average bolt pretension can be expected to exceed the minimum required bolt pretension by approximately 26% [6]. Field studies are available that support the conclusions insofar as bolts installed by turn-of-nut are concerned [30].

Calibrated wrench installations will produce pretensions much closer to the target values and they will be independent of the actual strength of the bolt, as has been explained previously. Based on laboratory studies, but using an allowance for a bolt installed in a solid block (i.e., joint) as compared to the more flexible hydraulic calibrator, it is shown that the minimum required pretension is likely to be exceeded by about 13% [6]. The value 13% was calculated using an assumed target of 7.5% greater than the specified minimum value. If the calibration is done to the exact value required by the RCSC Specification, which is a +5% target, then pretensions can be expected to be about 11% greater than the specified minimum values. The pretensions in bolts installed using a calibrated wrench have not been examined in field joints.

It is shown in Section 5.2 that these observed bolt tension values are a component of the design rules for slip-critical connections.

3.2.4 Tension-Control Bolts

Tension-control bolts, ASTM F1852, are fasteners that meet the overall requirements of ASTM A325 bolts, but which have special features that pertain to their installation [31]. In particular, the bolt has a splined end that extends beyond the threaded portion of the bolt and an annular groove between the threaded portion of the bolt and the splined end. Figure 3.5 shows an example of a tension-control bolt. The bolt shown has a round head (also called button or, dome, head), but it can also be supplied with the same head as heavy hex structural bolts. The bolt, nut, and washer must be supplied as an assembly, or, "set."

The special wrench required to install these bolts has two coaxial chucks—an inner chuck that engages the splined end and an outer chuck that envelopes the nut. The two chucks turn opposite to one another to tighten the bolt. At some point, the torque developed by the friction



Fig. 3.5 Tension-Control Bolt

between the nut and bolt threads and at the nut-washer interface overcomes the torsional shear resistance of the bolt material at the annular groove. The splined end of the bolt then shears off at the groove. If the system has been properly manufactured and calibrated, the target bolt pretension is achieved at this point. Factors that control the pretension are bolt material strength, thread conditions, the diameter of the annular groove, and the surface conditions at the nut-washer interface. The installation process requires just one person and takes place from one side of the joint only, which is often an economic advantage. The wrench used for the installation is electrically powered, and this can be advantageous in the field.

Research that investigated the pretension of production tension-control bolts as it varied from manufacturer to manufacturer and under different conditions of aging, weathering, and thread conditions is available [32]. The results show that the pretension in a tension control bolt is a strong reflection of the friction conditions that exist on the bolt threads, on the nut face, and on the washers supplied with the bolts. In this study, the quality of the lubricant supplied by the manufacturer varied, and in many cases the effectiveness of the lubricant decreased with exposure to humidity and the elements.

The installation of a tension-control bolt uses a method that depends on torque. As such, the process should be subject to the same pre-installation procedure demanded of calibrated wrench installation. Indeed, this is the requirement of the RCSC Specification [14]. If calibration is carried out in accordance with that Specification, it is reasonable to expect that the bolt pretensions from tension-control bolts will be similar to those reported for calibrated wrench installation.

3.2.5 Use of Direct Tension Indicators

Installation of high-strength bolts to target values of bolt pretension can also be carried out using direct tension indicators [33]. These are washer-type elements, as defined in ASTM F959 and shown in Fig. 3.6, that are placed under the bolt head or under the nut. As the nut is turned, small arch-shaped protrusions that have been formed into the washer surface compress in response to the pretension that develops in the bolt. If a suitable calibration has been carried out, the amount of pretension in the bolt can be established by measuring the size of the gap remaining as the protrusions close. This calibration requires that a number of individual measurements be made in a load-indicating device and using a feeler gauge to measure the gap.³ For example, there are five



Fig. 3.6 Direct Tension Indicator

protrusions in the direct tension indicating washer used with a 7/8 in. dia. A325 bolt. There must be at least three feeler gage refusals at the target value of the gap, which is 0.015 in. Details of the direct tension indicating washer itself and the procedure necessary for calibration are given in the RCSC Specification [14] and in the ASTM Standard [33]. Over and above the particularities of the direct tension indicating washer itself, the verification process is similar to that for calibrated wrench installation.

The use of the load-indicating washer to install high-strength steel bolts is a deformation method of control, and so it is not subject to the friction-related variables that are associated with the calibrated wrench and tension-control bolt methods. As is the case for the tension-control bolts, there are not many field studies of the effectiveness of direct tension indicators. The results that are available seem to be mixed. In one report [30] the ratio of measured pretension to specified minimum tension was 1.12 for a sample of 60 A325 bolts that used direct tension indicating washers. Although this is not as high as found in turn-of-nut installations, it is a satisfactory result. Other studies [34, 35], which encompassed only A490 bolts, indicate that specified minimum bolt tensions may not be reached at all when direct tension indicators are used to install large diameter, relatively long bolts. Some, but not all, of the difficulties reported relate to the bolt length and fastener grade, *per se*, rather than the use of the direct tension indicator. However, if the direct tension indicators are used in accordance with the requirements given in the RCSC Specification the bolt pretensions that are produced can be expected to be satisfactory.

3.3 Selection of Snug-Tightened or Pretensioned Bolts

All of the design specifications referenced in this document (i.e., RCSC, AISC, and AASHTO) require that the designer identify whether the bolts used must be pretensioned or need only be snug-tightened. The design documents must indicate the intention of the designer. In this way, the plan of the designer when the joint was proportioned will be fulfilled by those responsible for the

³ In practice, measurements are not performed, but a verifying feeler gage is used.

shop fabrication, field erection, and inspection of the work.

Bridges—In the great majority of cases, it will be required that the joints not slip under the action of the repetitive load that is present in all bridges. In the terminology of the RCSC Specification, this means that the joints must be designated as *slip-critical*. The AASHTO Specification permits *bearing-type* connections only for joints on bracing members and for joints subjected to axial compression. It is likely that most bridge documents will require slip-critical joints throughout in the interest of uniformity.

Buildings—The requirements for buildings allow more latitude in the selection of bolt installation. It is not usual for a building to have moving loads, and wind and earthquake forces are not considered to result in fatigue. Consequently, the need for pretensioned and slip-critical bolts is not as frequent in buildings as it is for bridges.

There are three conditions for bolted connections that can be used in buildings. For economy and proper function, it is important that the correct one be specified.

- Connections using Snug-Tightened Bolts

Neither the shear strength of a high-strength bolt nor the bearing capacity of the connected material are affected by the level of bolt pretension. Likewise, the tensile capacity is unaffected by bolt pretension, unless loads that might cause fatigue are present. (These items are discussed in Chapter 4.) Hence, the majority of bolted connections in buildings need only use snug-tightened bolts, i.e., the bolts are installed using the full effort of an ironworker with a spud wrench. This is the most economical way of making bolted connections in buildings because no compressed air or attendant equipment is needed, washers may not be required, and inspection is simple.

- Connections using Pretensioned Bolts

For buildings, only in certain cases is it required that the bolts be installed so as to attain a specified minimum pretension. These are enumerated in the RCSC Specification and they include (a) joints that are subject to significant load reversal, (b) joints subject to fatigue, (c) joints that are subject to tensile fatigue (A325 and F1852 bolts), and (d) joints that use A490 bolts subject to tension or combined tension and shear, with or without fatigue. The AISI LRFD Specification requires pretensioned bolts for some joints in buildings of considerable height or unusual configuration, or in which moving machinery is located.

It is obvious that the bolt installation costs and inspection for joints requiring pretensioned bolts will be higher than if the bolts need only be snug-tightened.

- Slip-Critical Connections

As described earlier, this type of connection is used mainly in bridges, where fatigue is a consideration. In buildings, wind is not considered to be a fatigue phenomena. However, if oversized holes or slotted holes that run parallel to the direction of the member forces are used, slip-critical connections are required in buildings. The RCSC Specification does stipulate that slip-critical connections be used when "slip at the faying surfaces would be detrimental to the performance of the structure." This is generally interpreted to include the joints in lateral bracing systems. It is important to note also that connections that must resist seismic forces need to receive special attention.

If slip-critical connections are used unnecessarily in buildings, higher installation and inspection costs will result.

3.4 Inspection of Installation

3.4.1 General

Inspection of the installation of any fabricated steel component is important for several reasons. It is self-evident that the integrity of the component must be assured by the inspection process. At the same time, the inspection must be done at a level that is consistent with the function of the element under examination and an understanding of its behavior. For example, if the inspection agency thinks (incorrectly) that bolt pretensions are subject to a maximum value as well as a minimum value, this will lead to a dispute with the steel erector and an unnecessary economic burden. In sum, then, the level of inspection must be consistent with the need to examine the suitability of the component to fulfill its intended function, but it must not be excessive in order that the economical construction of the job is not affected.

In the case of high-strength bolts, the first step must be an understanding of the function of the fastener in the joint. If bolt pretension is not required, then the inspection process should not include examination for this feature. This seems self-evident, but experience has proven that inspection for bolt pretension still goes on in cases where bolt pretension is, in fact, not required.

The most important features in the inspection of installation of high-strength bolts are:

- To know whether bolt pretension is required or not. If bolt pretension is not required, do not inspect for it.
- To know what pre-installation verification is required and to monitor it at the job site on a regular basis.
- To observe the work in progress on a regular basis.

Using acoustic methods, it is possible to determine the pretension in high-strength bolts that have been installed in the field with reasonable accuracy [29, 30]. However, this process, which determines bolt pretension by sending an acoustic signal through the bolt, is uneconomical for all but the most sophisticated applications. The inspector and the designer must realize that it is a reality that the bolt pretension itself cannot be determined during the inspection process for most building and bridge applications. Therefore, the importance of the checklist given on the previous page cannot be overstated.

The AISC LRFD Specification stipulates that inspection of bolt installation be done in accordance with the RCSC Specification. The remarks that follow highlight the inspection requirements: the text specific to the RCSC requirements should be consulted for further details.

3.4.2 Joints Using Snug-Tightened Bolts

For those joints where the bolts need only to be brought to the snug-tight condition, inspection is simple and straightforward. As described earlier, there is no verification procedure associated with snug-tightened bolt installation. The inspector should establish that the bolts, nuts, washers (if required), and the condition of the faying surfaces of the parts to be connected meet the RCSC Specification requirements. Hole types (e.g., oversize, slotted, normal) shall be in conformance with the contract documents. The faying surfaces shall be free of loose scale, dirt, or other foreign material. Burrs extending up to 1/16 in. above the plate surface are permitted. The inspector should verify that all material within the grip of the bolts is steel and that the steel parts fit solidly together after the bolts have been snug-tightened. The contact between the parts need not be continuous.

These requirements apply equally to A325 and A490 high-strength bolts and to A307 ordinary bolts.

3.4.3 Joints Using Pretensioned Bolts

If the designer has determined that pretensioned bolts are required, then the inspection process becomes somewhat more elaborate than that required for snug-tightened bolts. In addition to the requirements already described for snug-tightened bolts, the principal feature now is that a verification process must be employed and that the inspector observe this pre-installation testing. For any method selected, this testing consists of the installation of a representative number of fasteners in a device capable of indicating bolt pretension. (See Section 3.2.2 for a description of this process.) The inspector must ensure that this is carried out at the job site and, in the case of calibrated wrench installation, it must be done at least daily. If any conditions change, then the pre-installation testing must be repeated for the new situation. For

example, if the initial calibration of tension-control bolts was done for 4 in. long 3/4 in. diameter A325 bolts but 6 in. long 3/4 in. diameter bolts of the same grade must also be installed on the same day, then a second calibration is required.

In the case of turn-of-nut pretensioning, routine observation that the bolting crew applies the proper rotation is sufficient inspection. Alternatively, match-marking can be used to monitor the rotation. Likewise, if calibrated wrench installation has been used, then routine observation of the field process is sufficient. Because this method is dependent upon friction conditions, limits on the time between removal from storage and final pretensioning of the bolts must be established.

Inspection of the installation of twist-off bolts is also by routine inspection. Since pretensioning of these bolts is by application of torque, a time limit between removal of bolts, nuts and washers and their installation is required, as was the case with calibrated wrench installation. Observation that a splined tip has sheared off is not sufficient evidence in itself that proper pretension exists, however. This only signifies that a torque sufficient to shear the tip was present in the installation history. It is important that twist-off bolts first be able to sustain twisting without shearing during the snugging operation. It is therefore important that the inspector observe the pre-installation of fastener assemblies and assess their ability to compact the joint without twist-off of tips.

For direct-tension indicator pretensioning, routine observation can be used to determine that the washer protrusions are oriented correctly and that the appropriate feeler gage is accepted in at least half of the spaces between protrusions. After pretensioning, routine observation can be used to establish that the appropriate feeler gage is refused in at least half the openings. As was the case for twist-off bolts, simply establishing that the indicator washer gaps have closed can be misleading. The snug-tightening procedure must not produce closures in one-half or more of the gaps that are 0.015 in. or less.

3.4.4 Arbitration

The RCSC Specification provides a method of arbitration for bolts that have been installed and inspected according to one of the approved methods, but where disagreement has arisen as to the actual pretension in the installed bolts. A manual torque wrench is used to establish an arbitration torque that can then be applied to the bolts in question. As is pointed out in the Commentary to the RCSC Specification, such a procedure is subject to all of the uncertainties of torque-controlled calibrated wrench installation. In addition, other elements necessary to control the torque-related issues may be absent. For example, an installation done originally by turn-of-nut with no washers will be influenced by this absence of washers when the arbitration inspection is applied.

Passage of time can also significantly affect the reliability of the arbitration. There is no doubt that the arbitration procedures are less reliable than a properly implemented installation and inspection procedure done in the first place. Those responsible for inspection should resort to arbitration only with a clear understanding of its inherent lack of reliability.

Chapter 4

BEHAVIOR of SINGLE BOLTS

4.1 Introduction

The behavior of single bolts in tension, shear, or combined tension and shear is presented in this chapter. Features associated with each of these effects that are particular to the action of a bolt when it is part of a group, that is, in a connection, are discussed subsequently. Only the behavior of single bolts under static loading is discussed in this chapter: fatigue loading of bolted joints is presented in Chapter 7 and the effect of prying forces is discussed in Section 6.3.

4.2 Bolts in Tension

The load vs. deformation response of three different bolt grades was shown in Fig. 1.2. Such tests are carried out on full-size bolts, that is, they represent the behavior of the entire bolt, not just a coupon taken from a bolt. Consequently, the tests display the characteristics of, principally, the shank and the threaded portion. Obviously, strains will be largest in the threaded cross-section and most of the elongation of the bolt comes from the threaded portion of the bolt between the thread runout and the first two or three engaged threads of the nut.

The actual tensile strength of production bolts exceeds the specified minimum value by a fairly large margin [6]. For A325 bolts in the size range 1/2 in. to 1 in. diameter, the measured tensile strength is about 18% greater than the specified minimum value, (standard deviation 4.5%). For larger diameter A325 bolts, the margin is even greater. For A490 bolts, the actual tensile strength is about 10% greater than the specified minimum value (standard deviation 3.5%).

Loading a bolt in tension after it has been installed by a method that introduces torsion into the bolt during installation (i.e., by any of the methods described in Section 3.2) shows that its inherent tensile strength has not been degraded. The torque that was present during the installation process is dissipated as load is applied (see Section 3.2.1). Thus, the full capacity of the bolt in tension is available. In the case of bolts that were pretensioned during installation, the only other question that arises is whether the tension in the pretensioned bolt increases when a tension load is applied to the connected parts.

As discussed in Chapter 3, when a bolt is pretensioned it is placed into tension and the material within the bolt grip is put into compression. If the connected parts are subsequently moved apart in the direction parallel to the axis of the bolt, i.e., the joint is placed into tension, then the compressive force in the connected material will decrease and the tensile force in the bolt will increase. For elastic conditions, it can be

shown [6] that the resulting bolt force is the initial bolt force (i.e., the pretension) multiplied by the quantity $[1 + (\text{bolt area} / \text{plate area associated with one bolt})]$. For the usual bolt and plate combinations, the contributory plate area is much greater than the bolt area. Thus, the multiplier term is not much larger than unity. Both theory and tests [6] show that the increase in bolt pretension up to the load level at which the connected parts separate is in the order of only 5 to 10%. This increase is small enough that it is neglected in practice. Thus, the assumption is that under service loads that apply tension to the connected parts a pretensioned bolt will not have any significant increase in internal load. This topic is covered more fully in Chapter 6.

Once the connected parts separate, the bolt must carry the entire imposed external load. This can be easily shown with a free-body diagram. After separation of the parts, for example when the ultimate load condition is considered, the force in the bolt will directly reflect the external loads, and the resistance will be that of the bolt acting as a tension link. Figure 4.1 shows diagrammatically how the internal bolt load increases slightly until the applied external load causes the connected parts to separate. After that, the applied external load and the force in the bolt must be equal.

In principle, the tensile design strength of a single high-strength bolt should be the product of a cross-sectional area, the minimum tensile strength of the bolt, and a resistance factor. The AISC LRFD rule for the capacity of a bolt in tension directly reflects the discussion so far. According to Section J3.6 of the Specification, the design tensile strength (ϕR_n) is to be calculated as—

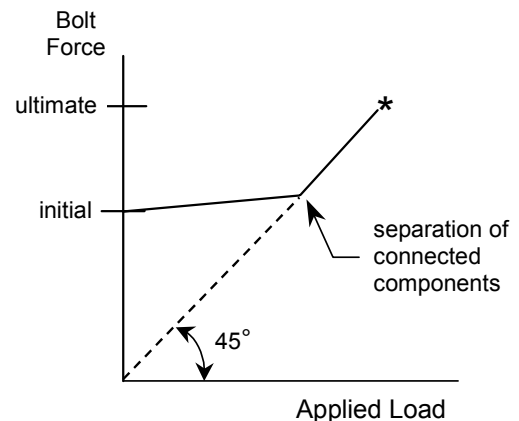

Fig. 4.1 Bolt Force vs. Applied Load for Single Pretensioned Bolt

$$\phi R_n = \phi F_t A_b \quad (4.1)$$

where ϕR_n = design tension strength in tension, kips

ϕ = resistance factor, taken as 0.75

F_t = nominal tensile strength of the bolt, ksi

A_b = cross-sectional area of the bolt corresponding to the nominal diameter, in.²

The nominal tensile strength of a threaded fastener (R_n) should be the product of the ultimate tensile strength of the bolt (F_u) and some cross-sectional area through the threads. As discussed in Section 1.3, the area used is a defined area, the tensile stress area (A_{st}), that is somewhere between the area taken through the thread root and the area of the bolt corresponding to the nominal diameter. The expression is given in Eq. 1.1. Rather than have the designer calculate the area A_{st} , the LRFD Specification uses an average value of this area for bolts of the usual structural sizes corresponding to the bolt diameter—0.75 times the area corresponding to the nominal bolt diameter.¹ Thus, the nominal tensile strength $F_u A_{st}$ can be expressed as $F_u(0.75A_b)$. The nominal tensile strength is written as $F_t A_b$ in Eq. 4.1. Equating these two expressions, it is seen that $F_t = 0.75 F_u$. Recall that the ultimate tensile strengths of A325 and A490 bolts are 120 ksi and 150 ksi, respectively. Application of the 0.75 multiplier to change nominal bolt cross-sectional area to tensile stress area gives adjusted stresses (F_t) of 90 ksi and 113 ksi for A325 and A490 bolts, respectively.

These are the values listed in Table J3.2 of the Specification. Note that the decreased ultimate tensile strength of larger diameter A325 bolts (105 ksi) is not taken into account. It was judged by the writers of the Specification to be an unnecessary refinement.

The same remarks apply generally to A307 bolts acting in tension. The nominal strength value given in Table J3.5 for A307 bolts is 45 ksi, which is the product $0.75 F_u$, given that the tensile strength of A307 bolts is 60 ksi.

It was established in Reference [22] that a resistance factor $\phi = 0.85$ is appropriate for high-strength bolts in tension. This is also the value recommended in the *Guide* [6]. Thus, the choice of 0.75 for use in Eq. 4.1 is conservative. To some extent, the choice reflects the fact that some bending might be present in the bolt, even though the designer calculates only axial tension.

The strength of a single bolt in tension is a direct reflection of its ultimate tensile strength. However, there are several features that can degrade the strength when the bolt is acting in a connection. These are discussed in Chapter 6.

4.3 Bolts in Shear

The response of a single bolt in shear is shown in Fig. 4.2 for both A325 and A490 bolts. The type of test illustrated is done using connecting plates that are loaded in compression. Similar tests done using connection plates loaded in tension show slightly lower bolt shear strengths [6]. (The difference is the result of lap plate prying in the tension jig tests, which creates a combined state of stress,

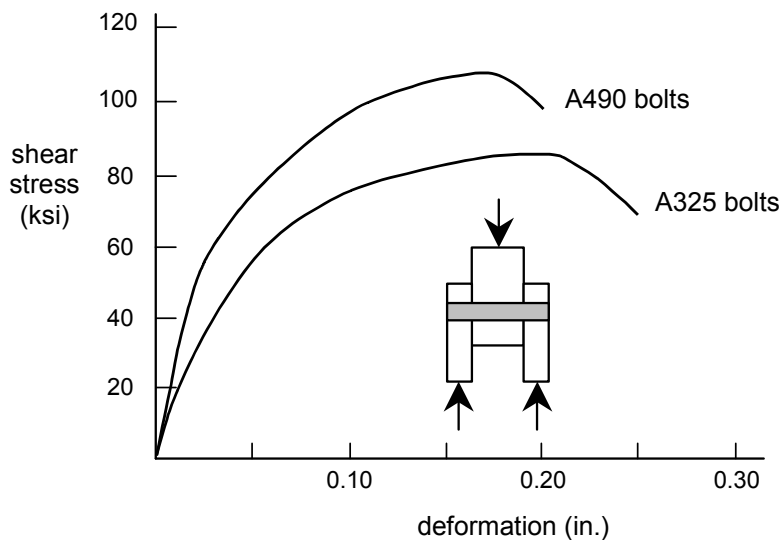

Fig. 4.2 Typical Shear Load vs. Deformation Curves for A325 and A490 Bolts

¹ The value 0.75 under discussion here is not the value $\phi = 0.75$ that appears in Eq. 4.1.

shear plus tension, in the bolt.) It should be noted that there is little, if any, portion of the response that can be described as linear. Thus, the best measure of the shear capacity of a bolt is its ultimate shear strength. The use of some so-called bolt yield strength is not appropriate.

The tests show that the shear strength of a bolt is directly related to its ultimate tensile strength, as would be expected. It is found [6] that the mean value of the ratio of bolt shear strength to bolt tensile strength is 0.62, standard deviation 0.03. An obvious question arising from the bolt shear tests is whether the level of pretension in the bolt affects the results. Test results are clear on this point: the level of pretension present initially in the bolt does not affect the ultimate shear strength of the bolt [6]. This is because the very small elongations used to introduce the pretension are released as the bolt undergoes shearing deformation. Both test results of shear strength for various levels of initial pretension and bolt tension measurements taken during the test support the conclusion that bolt pretensions are essentially zero as the ultimate shear strength of the bolt is reached. This has implications for inspection, among other things. If the capacity of a connection is based on the ultimate shear strength of the bolts, as it is in a so-called bearing-type connection, then inspection for pretension is pointless, even for those cases where the bolts were pretensioned.

The other feature concerning bolt shear strength has to do with the available shear area. If the bolt threads are intercepted by one or more shear planes, then less shear area is available than if the threads are not intercepted. The experimental evidence as to what the reduction should be is not clear, however. Tests done in which two shear planes were present support the idea that the shear strength of the bolt is a direct reflection of the available shear area [6]. For example, if one shear plane passed through the threads and one passed through the shank, then the best representation was obtained using a total shear area which is the sum of the thread root area plus the bolt shank area. These results support the position that the strength ratio between shear failure through the threads and shear failure through the shank was about 0.70, i.e., the ratio of thread root area to shank area for bolts of the usual structural sizes. On the other hand, in single shear tests this ratio was considerably higher, about 0.83 [36, 37]. Both the RCSC Specification [14] and the AISC LRFD Specification [17] use the higher value, slightly rounded down to 0.80. At the present time, the difference is unresolved.

The AISC LRFD rule for the design strength of a bolt in shear follows the discussion presented so far. The rule is given in Article J3.6 of the Specification, as follows:

$$\phi R_n = \phi F_v A_b \quad (4.2)$$

where ϕR_n = design shear strength, kips

ϕ = resistance factor, taken as 0.75

F_v = nominal shear strength, ksi

A_b = cross-sectional area of the bolt corresponding to the nominal diameter, in.² The calculation of A_b should reflect the number of shear planes present.

As listed in Table J3.2 of the Specification, the nominal shear strength of the bolt is to be taken as 60 ksi or 75 ksi for A325 or A490 bolts, respectively, when threads are excluded from the shear plane. These values are 0.50 times the bolt ultimate tensile strengths (120 ksi for A325 bolts and 150 ksi for A490 bolts). If threads are present in the shear plane, the nominal shear strength is to be taken as 48 ksi or 60 ksi for A325 or A490 bolts, respectively. The latter values are 80% of the thread-excluded case, as explained above.

An explanation is required as to why 0.50 is used rather than 0.62, which was identified earlier as the proper relationship. If only one bolt is present, obviously that bolt carries all the shear load. If two bolts aligned in the direction of the load are present, each carries one-half of the total load. However, for all other cases, the bolts do not carry a proportionate share of the force. As is explained in Section 5.1, the end bolt in a line of fasteners whose number is greater than two will be more highly loaded than fasteners toward the interior of the line. The effect increases with the number of bolts in the line. The Specification takes the position that even relatively short joints should reflect this effect. Accordingly, the relationship between bolt shear strength and bolt ultimate tensile strength is discounted by 20% to account for the joint length effect. The product $0.62 \times 80\%$ is 0.50, which is the value used in the AISC rule for shear capacity. If the joint is 50 in. or longer, a further 20% reduction is applied.

The resistance factor used for bolts in shear (Eq. 4.2) is $\phi = 0.75$. Until the effect of joint length upon bolt shear strength is presented (Section 5.1), the selection of 0.75 cannot be fully discussed. However, it can be noted that the resistance factor recommended by the *Guide* [6], which is based on the study reported in Reference [22], is 0.80.

4.4 Bolts in Combined Tension and Shear

Figure 1.5 showed how bolts can be loaded in such a way that both shear and tension are present in the bolt. Chesson et al. [38] carried out a series of tests on bolts in this condition, and these test results form the basis for the AISC LRFD rules. Two grades of fastener were tested: A325 bolts and A354 grade BD bolts. The latter have mechanical properties equivalent to A490 bolts. The test program showed that the only variable other than bolt grade that affected the results was bolt length. This was expected: as bolt length increases bending takes place and the bolt shear strength increases slightly. (This is the

consequence of the fact that the shear planes through a curved bolt are slightly larger than if the bolt were straight.)

An elliptical interaction curve was fitted to the test results. The expression given in the *Guide* [6], which is applicable to both A325 and A490 bolts, is:

$$\frac{x^2}{(0.62)^2} + y^2 = 1.0 \quad (4.3)$$

where x = ratio of calculated shear stress (τ) to bolt tensile strength (σ)

y = ratio of calculated tensile stress (σ) to bolt tensile strength (σ)

The shear stress is calculated on the applicable area, the shank or through the threads, and the tensile stress is calculated on the tensile stress area. The researchers [38] also suggested a three-straight line approximation to the results, and this is the model used in the LRFD rules.

The requirements for bolts in combined shear and tension are in AISC LRFD Article J3.7 and Table J3.5. The LRFD rules use a three straight-line approximation of the ellipse that is fitted to the test results (Eq. 4.3), adjusted to match the permissible tensile strength and shear strength limits established by LRFD for each of these conditions acting singly. The rules present a straight line cutoff at the maximum permissible tensile stress, a straight line cutoff at the maximum permissible shear stress, and a sloping straight line in-between.

For A325 bolts when the shear plane will pass through the shank only, the interaction equation is:

$$F_t = 117 - 2.0 f_v \leq 90 \quad (4.4)$$

and for A325 bolts when the shear plane will pass through the threads:

$$F_t = 117 - 2.5 f_v \leq 90 \quad (4.5)$$

For A490 bolts and no threads in the shear plane:

$$F_t = 147 - 2.0 f_v \leq 113 \quad (4.6)$$

and for A490 bolts in which there are threads in the shear plane:

$$F_t = 147 - 2.5 f_v \leq 113 \quad (4.7)$$

Equations 4.4 through 4.7 use the AISC LRFD notation for stresses. The resistance factor $\phi = 0.75$ must be applied to the result obtained by these equations. When the design tension strength of the bolt (now reduced by the presence of shear) is determined using Equation 4.1, the resistance factor appears in that equation.

In applying these rules, it is apparent that the tensile stress is limited to the nominal tensile strength of the bolt, 90 ksi for A325 and 113 ksi for A490. It should be remembered, as well, that there is also a limit on the calculated shear stress, f_v (computed under the factored

loads). It must be equal to or less than the nominal shear strength multiplied by the resistance factor.

An advantage of the straight-line representation is that it identifies the range of shear stress values for which a reduction in tensile strength needs to be made. For example, a reduction in tensile strength for A325 bolts (no threads in shear plane) is required when the calculated shear stress under the factored loads is between 13.5 ksi and the maximum permitted value of 45 ksi (i.e., $60 \text{ ksi} \times \phi$). At the former, the nominal tensile stress is, of course, 90 ksi, and at the latter it has been reduced to 27 ksi.

The elliptical representation and the straight-line representation fit the test data about equally well when the forms presented in Reference [26] are applied. In the formulation used by AISC (Equations 4.4 through 4.7), the result will be conservative. It has already been pointed out in this Chapter that the AISC LRFD rules for the tension-only and the shear-only cases are themselves conservative.

Chapter 5

BOLTS IN SHEAR SPLICES

5.1 Introduction

Figure 1.3 (a) showed a symmetric butt splice that uses plates to transfer the force from one side of the joint, say, the left-hand main plate, to the other, the right-hand main plate. (Most often, the main plate shown in this pictorial will actually be a structural shape like a W-shape, but the behavior can be more easily described using a plate.) Such a connection is used, for instance, to splice the chord of a truss.

The behavior of a large splice that was tested in the laboratory is shown in Fig. 5.1 [6]. This joint used ten 7/8 in. dia. A325 bolts in each of two lines. The holes were sub-drilled and then reamed to 15/16 in. dia., that is, they were 1/16 in. dia. larger than the bolts. The bolts were pretensioned using the turn-of-nut method. The plates were ASTM A440 steel and the measured strengths were 42.9 ksi static yield strength and 76.0 ksi ultimate. The slip coefficient of this joint was measured as 0.31.

The load vs. deformation response is reasonably linear until the joint slips. Following slip, which means that the plates are pulled up against the sides of at least some of the bolts, the joint at first continues to load at more or less the same slope as the initial region. Yielding of the connected material starts to occur, however, first in the net cross-section and then throughout the connected material. The ultimate load that this joint could carry corresponded to an average bolt shear stress of 67.0 ksi. However, tests of single bolts taken from the same manufacturing lot showed that the shear stress at failure was 76.9 ksi.

The behavior of this joint, which is reasonably representative of splices of this type, raises the following points:

- How much slip is likely to take place?
- Why is the average bolt shear stress at failure of the multi-bolt joint less than the bolt shear stress when a single bolt is tested?

If the bolts had not been pretensioned, the connected material would have been expected to pull up against the sides of the bolts at a relatively low load. In the case of the joint depicted in Fig. 5.1, this slip did not occur until the frictional resistance had been overcome, of course. In the most unfavorable condition, the amount of slip can be two hole clearances, i.e., 1/8 in. in this case. Since the bolts and their holes cannot all be expected to be in their "worst" locations, the amount of slip that actually takes place is observed to be much less than two hole clearances. In laboratory specimens, the amount of slip in such joints is about one-half a hole clearance [6], and values measured in the field are even less [39]. Thus, unless oversize or slotted holes are used, it can be expected that if joint slips occur they will be relatively small.

The reason that the average ultimate bolt shear stress in a multi-bolt joint is less than that of a single bolt can be explained qualitatively with the aid of Fig. 5.2. In plate *A* (the main plate) 100% of the load is present in the plate until the bolts start to transfer some load into the lap plates (plates *B* in the figure). Consider a high load, say, near ultimate. In plate *A* between bolt lines 1 and 2 the stress in the plate will still be high because only a small

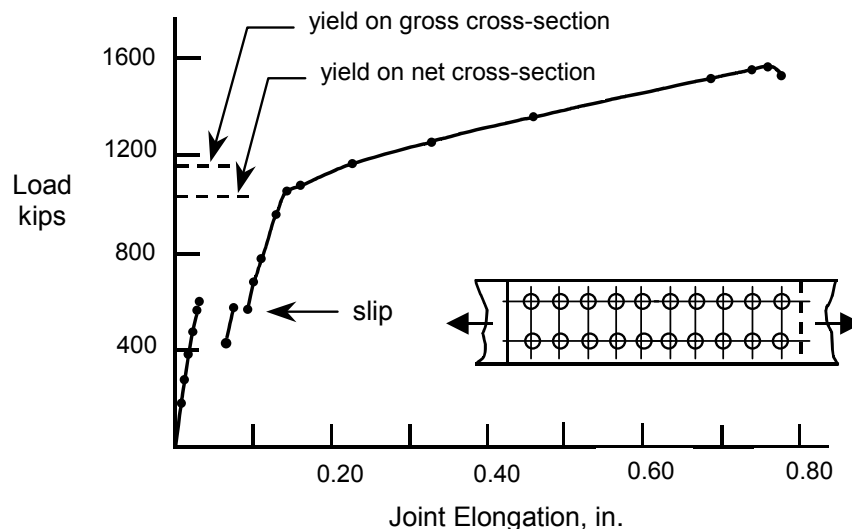

Fig. 5.1 Load vs. Elongation Behavior of a Large Joint

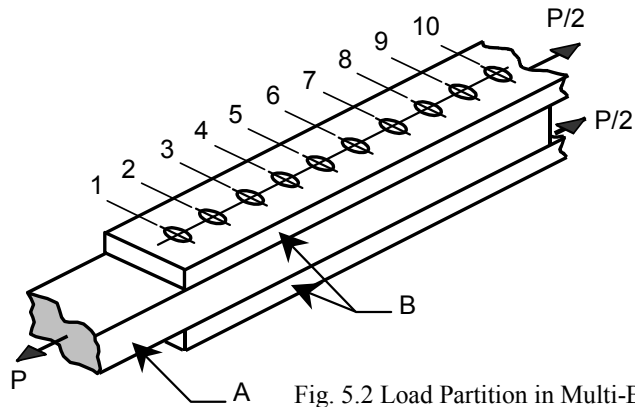

Fig. 5.2 Load Partition in Multi-Bolt Joint

amount of load has been removed (by bolt 1). Strains in this plate are correspondingly high. Conversely, the stress in the lap plates *B* between lines 1 and 2 is low because only a small amount of force has been taken out of the main plate and delivered to the lap plates. Thus, strains in the lap plates between bolt lines 1 and 2 will be low. This means that the differential in strain between plates *A* and *B* will be large in the region near the end of the joint.

Consider now the region near the middle of the joint, say, between bolt lines 5 and 6. Whatever the distribution of shear forces in the bolts, a considerable amount of the total joint force has now been taken out of plate *A* and put into plates *B*. Thus, the strains in the former have decreased as compared to the condition near the end of

the joint and the strains in the latter have increased. Consequently, the differential in strains between the two plate systems is less near the middle than it was near the end. Since the bolt shear force is the result of the imposition of these relative strains [6], bolts near the end of a joint will be more highly loaded than those toward the middle. It is worth noting that this uneven loading of the bolts in shear is accentuated as the joint load is increased from zero. It used to be argued that, even though the bolt shear force distribution was uneven at working loads, it would equalize as the ultimate load condition was reached. In fact, the converse is true.

The uneven distribution of forces in a multi-bolt shear splice can be seen in Fig. 5.3. Shown in this sawn section are the end four bolts in a line of 13. The top bolt (the end bolt) is close to failure, whereas the fourth bolt from the top has significantly less shear deformation and, hence, shear force.

The designer must decide first whether a slip-critical connection is needed or not. If it is, then the appropriate design rules must be identified. If a bearing-type joint is satisfactory, then those design rules must be followed. (Bearing-type design implies both bolt shear strength and the bearing capacity of the connected material, as explained in Section 1.4) Because slip-critical joints are designed at the service load level, it is also a requirement that the ultimate strength criteria, i.e., the bearing-type joint rules, be met at the factored load level. The remaining sections in this Chapter will discuss these issues.

5.2 Slip-Critical Joints

Section 3.3 discussed the cases where slip-critical connections are needed. If proper functioning of the structure requires that a joint not slip into bearing, then this requirement is described as a *serviceability* limit state. In building design according to the AISC LRFD specification, the requirement is that the joint not slip under the action of the service loads. It will be seen that the AISC LRFD specification also provides a rule for design of a slip-critical joint under the factored loads.

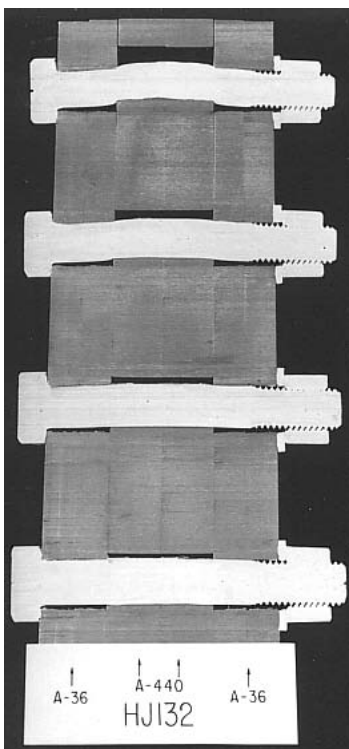

Fig. 5.3 Sawn Section of a Joint

This is primarily a matter of convenience: it is intended that the result be the same, more or less, whichever the starting point. In the case of the AASHTO specification for the design of bridges, prevention of slip is required under a force that includes the service load multiplied by 1.30.

From first principles, the slip resistance of a bolted joint can be expressed as:

$$P = k_s n \sum T_i \quad (5.1)$$

where k_s = slip coefficient of the steel

n = number of slip planes (n is usually either one or two)

T_i = bolt pretension (in each individual bolt)

Neither the slip coefficient nor the bolt tension forces are deterministic. They are reasonably represented as log-normally distributed and can therefore be characterized by a mean value and its standard deviation. Given this type of information, which is available from laboratory studies on full-size joints, it is possible to determine a probability of slip for given starting conditions [6]. The result reflects two important realities, described following.

As-delivered bolts have a tensile strength that is greater than the specified minimum tensile strength. For A325 bolts, this increase is about 20% and for A490 bolts it is about 7% [22].

The pretension in installed bolts will be greater than the specified minimum pretension, which is 70% of the bolt specified ultimate tensile strength. Generally, the pretension in bolts installed by turn-of-nut will be greater than that for bolts installed by calibrated wrench.

In order to provide a design equation, a probability of slip must be selected. Based on past experience, this was taken by the *Guide* [6] to be about 5% when turn-of-nut installations are used and about 10% when calibrated wrench is used. (The examination at the time did not include twist-off bolts or bolts that use load-indicating washers.) In the RCSC Specification [14], this design equation is written as:

$$R_s = \phi \mu D T_m N_b N_s \quad (5.2)$$

where

R_s = slip resistance of the joint

N_b = number of bolts

N_s = number of slip planes

μ = slip coefficient ($\equiv k_s$ in Eq. 5.1)

T_m = specified minimum bolt pretension

$D = 0.80$, a slip probability factor that reflects the distribution of actual slip coefficients about their mean value, the ratio of measured bolt tensile strength to the specified minimum values, and

the slip probability level (e.g., 5% in the case of turn-of-nut installation).

ϕ = modifier to reflect the hole condition (standard, oversize, short-slotted, long-slotted in direction of force, or long-slotted perpendicular to force). Note that the term ϕ in this equation is not the resistance factor usually associated with LRFD.

It can be seen that Eq. 5.2 is basically the same as Eq. 1, which expressed the slip load in fundamental terms. The modifier ϕ is used to reflect the decrease in bolt pretension that is present when oversize or slotted holes are used. The term D embodies the slip probability factor selected and provides the transition between mean and nominal bolt tension and slip values. In the form given by Eq. 5.2, the *Guide* can be used to obtain slip loads for other failure probabilities and various other conditions when necessary.

The AISC LRFD rules for design of slip-critical connections are presented in both factored load terms (Article J3.8a) and in service load terms (Article J3.8b).

The LRFD expresses the slip load resistance per bolt when factored loads are used as (Article J3.8a) —

$$\phi R_{str} = \phi 1.13 \mu T_m N_s$$

In this form, the resistance equation is closely identified with Eq. 5.2, i.e., it expresses the resistance in terms of the fundamentals of the problem—clamping force (T_m), slip coefficient (μ), and the number of slip planes (N_s). The ϕ -value, described in the specification as a resistance factor, is really the adjustment required for hole configuration, as discussed above.¹ The modifier 1.13 reflects the observed increase in bolt clamping force (above the specified minimum bolt tension, T_m) when the calibrated wrench method of installation is used [6].

An advantage of the factored load design is that cases other than clean mill scale can be accommodated. Most importantly, the expression reflects the principles involved.

The requirements for slip-critical design when the service loads are used as the starting point (Article J3.8b) are actually in Appendix J3.8b. In the service load presentation, the result is given in the form of permissible bolt shear stress. Unfortunately, this obscures the fundamentals of the design problem, i.e., the relationship of the slip load to the surface condition of the faying

¹ In the LRFD Specification, the modifier ϕ is taken as unity for standard, oversized, short-slotted, and long-slotted holes when the long slot is perpendicular to the line of the force. For long-slotted holes when the long slot is parallel to the line of the force, $\phi = 0.85$. Further information on the effect of oversize or slotted holes can be found in Section 8.3.

surfaces and to the clamping force provided by the bolts (Eq. 5.1 or 5.2). In a slip-critical connection the bolts do not act in shear. It is not until the slip resistance has been overcome that shear forces act on the bolts.

Appendix J3.8b says that the design resistance to shear per bolt is $\phi F_v A_b$. The modifier ϕ has already been described above for load factor design. The cross-sectional area of the bolt is expressed as A_b . The permissible shear stress, given in Table A–J3.2, is for so-called Class A surfaces with slip coefficient $\mu = 0.33$. (The designer is permitted to adjust the tabulated values if it is necessary to use another slip coefficient.)

The pseudo shear stress given in Table A–J3.2 can be derived by first expressing the resistance (force) of a single bolt in slip-critical joint in terms of this shear stress as—

$$\tau_b A_b N_s$$

where

τ_b = equivalent shear stress (i.e., the value tabulated in LRFD Table A–J3.2)

A_b = cross-sectional area of one bolt

Equate this to the resistance given by Eq. 5.2 and use the particular case of one bolt ($N_b=1$) and standard size hole size ($\phi = 1.0$):

$$\tau_b A_b N_s = \mu D T_m N_s$$

Solving for the shear stress

$$\tau_b = \frac{\mu D T_m}{A_b}$$

but, $T_m = 0.70 A_{st} \sigma_u$ (see Section 3.2.1)

where A_{st} is the tensile stress area of the bolt and σ_u is the bolt ultimate tensile strength. Making this substitution—

$$\tau = \frac{\mu D 0.70 A_{st} \sigma_u}{A_b}$$

For bolts of the usual structural size, the ratio A_{st}/A_b is about 0.76. A value for the slip probability factor, D , has to be obtained from the *Guide* [6]. For the particular case of A325 bolts ($\sigma_u = 120$ ksi) and clean mill scale steel ($\mu = 0.33$), the value of D is 0.820. Making the substitutions, an equivalent shear stress of 17.3 ksi is calculated. In the AISC LRFD specification, Table A–J3.2 gives a shear stress of 17 ksi for this case. Other cases can be derived in a similar fashion.

Whether the slip-critical connection has been designed at the service load level or at the factored load equivalent, as just described, it is necessary that the joint still be checked under the factored loads. This means evaluation of the shear strength of the fasteners and the

bearing capacity of the connected material. These topics are discussed in the next section.

5.3 Bearing-Type Joints

5.3.1 Introduction

If it is not required that a joint be slip-critical, then the design issues are the shear capacity of the bolts and the bearing capacity of the connected material. These were the features contemplated in the discussion presented in Section 1.4. There has already been some discussion about the shear capacity of a single bolt (Section 4.3) and the effect of joint length upon bolt shear strength (Section 5.1). In Section 5.3, the bolt shear capacity discussion will be completed and the subject of bearing capacity in the connected material will be presented.

5.3.2 Bolt Shear Capacity

The AISC LRFD rule for the capacity of a bolt in shear was presented in Section 4.3. In brief, Article J3.6 of the Specification stipulates that:

$$V_r = \phi F_v A_b \quad (4.2)$$

where V_r = factored shear resistance

ϕ = resistance factor, taken as 0.75

F_v = nominal shear strength of the bolt

A_b = cross-sectional area of the bolt, in.²

In Section 4.3, it was noted that the nominal shear strength of the bolt is to be taken as 0.50 times the bolt ultimate tensile strength (i.e., 120 ksi for A325 bolts and 150 ksi for A490 bolts), adjusted as necessary if threads are present in the shear plane.

The Specification takes the position that even relatively short joints should reflect the effect of joint length upon bolt shear strength. (The joint length effect was explained in Section 5.1.) Accordingly, the relationship between bolt shear strength and bolt ultimate tensile strength, which has been determined from tests to be 0.62, is immediately discounted by 20% to account for the joint length effect. Thus, the multiplier applied to bolt ultimate tensile strength in order to obtain the bolt shear strength is $0.62 \times 80\% = 0.50$. This is the value used to obtain the bolt nominal shear strength values given in Table J3.2 of the Specification. If the joint length exceeds 50 in., a further 20% reduction must be applied to Eq. 4.2.

The use of the 0.50 multiplier (rather than the value of 0.62) for the relationship between shear strength and bolt ultimate tensile strength and the use of 0.75 as the resistance factor create a conservative position for the AISC LRFD rules. In the *Guide*, it is established that no reduction in bolt shear strength with respect to joint length is required until joint length is about 50 in. In allowable stress terms, the factor of safety in joints up to that length is at least 2.0 for both A325 bolts and A490

bolts in higher strength steels (which is the conservative choice in the model). Thus, use of the 0.62 multiplier means that shorter joints will simply have a larger margin of safety. Since the 2.0 value was adequate (by experience) for long joints, no reduction is really necessary up to that joint length. The same comments generally apply in load factor design, given a load factor of about 1.6.

The selection of 0.75 as the resistance factor in the AISC rules is likewise conservative. The value of 0.80 is more appropriate, as developed in Reference [22].

Finally, a comment needs to be made regarding the application of the joint length effect to the type of connection in which load is transferred from a beam or girder web to another member, for example, a column. The length effect reduction is derived from the shear splice model. To what extent it applies to the web framing angles case is uncertain, but it is reasonable to think that the same phenomenon at least does not take place to the same degree. Indeed, one international specification [40] specifically excludes the joint length effect for the design of bolts in framing angle connections.

5.3.3 Bearing Capacity

The fashion in which the connected material reacts against a bolt that is loaded in shear was described in Article 1.4. Figure 1.6 (d) showed pictorially the bearing force acting against the connected material, and the actual effect of the contact between bolts and connected material can be seen in Fig. 5.3. The discussion in this section will deal with how the member (connected material) can reach its limit state in bearing and will also introduce the AISC LRFD Specification design rules.

Figure 1.6 showed the action of a single bolt. If this bolt is close to the end of the connected part (see Fig. 1.6 (d)), then obviously one possible limit state is that a block of material will shear out between the bolt and the end of the end of the connected part. The other possibility is that excessive deformations occur as the connected material yields. Often, a combination of these two features is observed in tests.

A rational model that describes the shearing behavior can be developed, and this is done in the *Guide* [6]. The model gives good agreement with test results, but a simpler model is also available that is sufficiently accurate. This uses a shear-out of a block of material between the end bolt and the adjacent connected material, shown as a dotted box in Fig. 5.4. This strength is $2(\tau_u \times L_c \times t)$. The relationship used to describe the ultimate shear strength is $\tau_u = 0.75 \sigma_u$. The multiplier 0.75, which might appear to be conservative, reflects the strain hardening that is observed and the fact that the shear surfaces are really longer than assumed. Thus, the shear resistance of this bolt is given by

$$R_n = 1.5 \sigma_u L_c t \quad (5.3)$$

In accordance with the concepts shown in Fig. 1.6, t must be the thinner of two connected parts. See also Fig. 5.4. If three (or more) plies are connected, t is the thinner of $t_1 + t_3$ or t_2 .

The relationship given by Eq. 5.3 becomes less valid when the end bolt is relatively far from the end of the connected material. This is because the failure mode changes from shearing out of material to excessive yielding. Based on the test results [6], the relationship between bearing stress and plate ultimate strength can be described as

$$\frac{\sigma_b}{\sigma_u^{pl}} = \frac{L_e}{d}$$

where L_e is shown in Fig. 5.4, d is the bolt diameter, and the other two terms are

σ_b = bearing capacity of the connected material

σ_u^{pl} = ultimate tensile strength of the connected material.

It is assumed that the bearing stress acts on a rectangular area $d \times t$. Solving the expression given above for the bearing stress and multiplying by this area gives a permissible load based on bearing capacity as

$$R_n = \left(\sigma_u^{pl} \frac{L_e}{d} \right) d t$$

From the tests, it is observed that this capacity controls for values of $L_e \geq 3 d$. Making this substitution and using the LRFD notation $F_u \equiv \sigma_u^{pl}$ gives

$$R_n = 3 d t F_u$$

This is written as a limit to Eq. 5.3, and the final expression given as LRFD J3-2c is written as

$$R_n = 1.5 \sigma_u L_c t \leq 3.0 d t F_u \quad (5.4)$$

Of course, Eq. 5.4 must still be multiplied by a

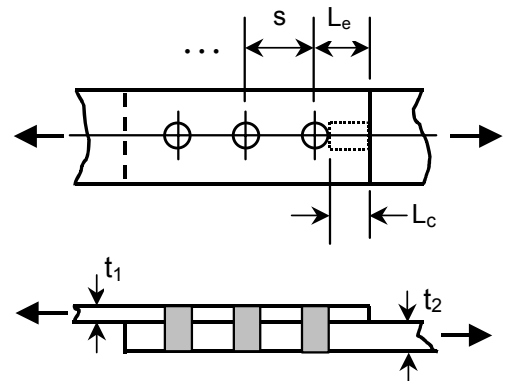

Fig. 5.4 Bearing Nomenclature

resistance factor, ϕ , to obtain the design bearing strength. The value $\phi = 0.75$ is used.

The case under discussion has been for a bolt in a standard hole, oversized hole, short-slotted hole, or long-slotted hole parallel to the direction of load, and for the circumstance where bolt hole deformation at service load is not a design consideration. A separate expression (LRFD J3-2c) is given for the same circumstances except that the long-slotted hole is oriented perpendicular to the direction of the force.

When bolt hole deformation is a consideration, the capacity is reduced and given as

$$R_n = 1.2 \sigma_u L_c t \leq 2.4 d t F_u \quad (5.5)$$

The user of the LRFD Specification is not given much help in deciding when deformation around holes should be a design consideration. Therefore it is instructive to look at the basis of Eq. 5.5.

Equation 5.5 was developed from tests reported in Reference [41]. Equation 5.5 is a limit based on deformation, and it was selected as the point at which 0.25 in. of joint deformation had been reached. According to these researchers, at about this deformation most of the ultimate strength had been reached in the tests and a considerable extension beyond this point is required to attain the full strength capacity. The test specimens were configured so that the critical element was the lap plates in a butt splice. In these tests, the lap plates could deform out-of-plane since they are unconfined by the assembly. A central conclusion in [41] is that tests in which the

unconfined plates fail as compared to tests in which the confined plates fail present significantly different conditions of bearing stress failure. Other noteworthy conditions in these tests were that the lap plates were very thin (1/4 in.) and the plates were sometimes very wide (up to 8 in.). An 8 in. wide plate containing a single line of bolts, as was the case in some of these tests, exceeds the maximum permissible edge distance permitted in the Specification. A further feature of some of the test specimens was large end distances, up to 9 in. This also would not be permitted under the limits in the Specification. Whatever limitations that might be present as a result of the geometrical features of these tests, the best measure is how these results compare to those done when the confined plates fail in bearing. This comparison is made in the *Guide* [6], where it is clear that the unconfined test results fall easily within the normal scatter of the total results. The only remaining question then is whether it is necessary to limit the deformation of any of the individual tests because ultimate bearing capacity only is attainable at large deformations.

It is the author's opinion that the majority of structural connections will not display the type of behavior demonstrated in these tests: component sizes in fabricated steel construction will be more robust than those reported in [41]. Furthermore, the concept of limiting deflections is arguable, as long as these deflections are within reason. The limit used, 0.25 in., could be increased to, say 3/8 in., without endangering the structure. It must be remembered that these deflections

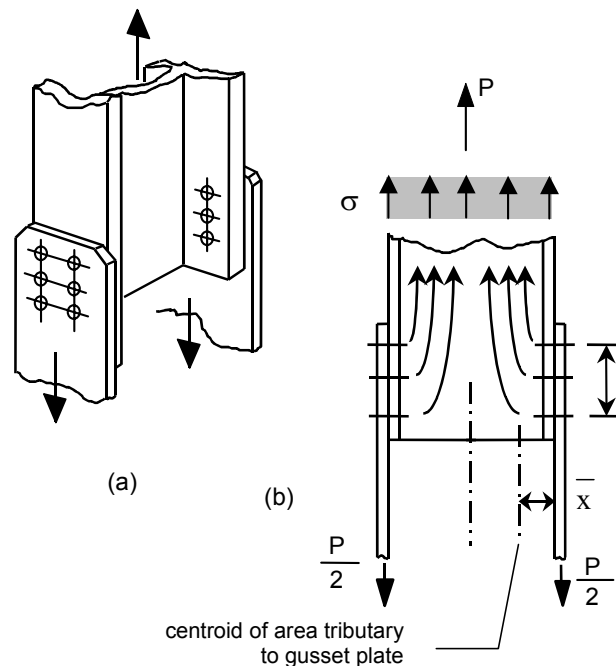

Fig. 5.5 Shear Lag in Gusset Plate Connection

are present only as the structure approaches its ultimate capacity. Second-order effects, even in multi-story buildings, will not be significant with slips of this magnitude.

The resistance factor to be applied to the bearing capacity equations given in the LRFD Specification is 0.75. This is one of the few locations where the Specification choice seems to be non-conservative as compared with published material. In Reference [22], the value is calculated to be 0.64.

5.4 Shear Lag

For truss members, it is usual to transfer the force into or out of the member by means of gusset plates, as shown in Fig. 5.5. Generally, it is impractical to try to connect all of the cross-section of the shape. For instance, as illustrated in Fig. 5.5(a), the flanges of the W-shape are attached to the gusset plates, but the web is not directly connected. Consequently, the flow of stress from the bolts into the W-shape must be something like that shown in Fig. 5.5(b). Intuitively, it is to be expected that a long connection will be more favorable for this stress flow. Likewise, if the shape is shallow, the stress flow will be more favorable than if it is deep. The effects of these features of the geometry have been demonstrated in physical testing.

Another example is shown in Fig. 5.6, where a single angle is connected to a gusset plate. In this case, the outstanding leg of the angle is not connected. Again, an uneven distribution of stresses from the fasteners into or out of the angle is expected and the outstanding leg of the angle may not be fully effective. What this means, in both the illustrations used, is that the full cross-sectional area of the shape may have to be discounted (in addition to the fact that holes are present) in order to be able to predict the capacity of the member. This phenomenon is referred to as *shear lag*.

The most obvious geometrical features that determines the severity of the shear lag are (a) the

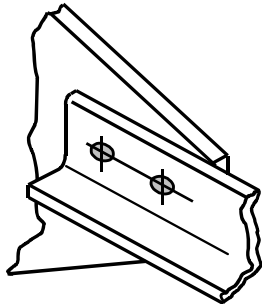

Fig. 5.6 Shear Lag in Angle Connection

displacement of the centroids of the gusset plates relative to the member and (b) the length of the connection. (If the joint is particularly long, then that itself can also have an effect, as was explained in Section 5.1.) Physical testing

has shown that other features such as the ductility of the material being joined, the method of making the holes (e.g., punched or drilled), the proximity of one hole to another, and so on, generally have a small influence.

Although a number of investigations have been performed to study the shear lag effect, the current North American design standards are based mostly on the work of Munse and Chesson [42, 43] This work included examination of different cross-sectional configurations, connections, materials, and fabrication methods. An empirical equation to calculate the net section efficiency was proposed. It was based on the test results of 218 specimens. This equation was verified further by a comparison with more than 1000 other test data. Using the assumption that the net area will be calculated using the so-called $s^2/4g$ rule and that the hole diameter will be taken as 1/16 in. greater than the actual hole size [20], then according to Munse and Chesson the predicted net section load of a tension member is given by

$$P_u = \left(1 - \frac{\bar{x}}{L}\right) A_n F_u \quad (5.6)$$

in which \bar{x} and L are terms that describe the geometry (Fig. 5.5), A_n is the net cross-sectional area, and F_u is the ultimate tensile strength of the material.

Direct use of Eq. 5.6 presents a problem for the designer because the length of the connection, L , must be known (or assumed) before it can be applied. Thus, an iterative solution is indicated.

The expression for the capacity of a tension member in the AISC LRFD Specification [17] is a direct reflection of Eq. 5.6. See Article B3 of the Specification. An upper limit of 0.9 is given for the term $1 - \bar{x}/L$, which is designated as U in the Specification. Again the difficulty mentioned above arises, that is, the calculation process must be iterative because the length of the connection is not known in advance of the design of the tension member. However, in the *Commentary* to the LRFD Specification, certain approximations for U are permitted. They are based on the examination of a large number of hypothetical cases, and are as follows.

- (a) W, M, or S shapes with flange width not less than 2/3 the depth (and structural tees cut from these shapes), provided the connection is to the flanges and there are at least 3 fasteners per line of bolts: use $U = 0.90$.
- (b) W, M, or S shapes (or structural tees) not meeting the requirements of (a) and all other shapes, provided the connection is to the flanges and there are at least 3 fasteners per line of bolts: use $U = 0.85$.
- (c) All members having only two fasteners per line: use $U = 0.75$.

These approximations seem to give satisfactory results for the cases involving W, M, or S shapes, and it is always easy to check the result using Eq. 5.6 once the details have been established. However, there is recent work that indicates that neither Eq. 5.6 or the use of the U -value approximations are satisfactory for angles that are connected by one leg [44]. For a large group of test specimens, taken from several different sources, it was found that Eq. 5.6 overestimated the ultimate load by a factor of 1.19, standard deviation 0.13 [44]. These researchers provide the following predictor equation for the strength of angles (either single or arranged as a pair)—

$$P_u = F_u A_{cn} + \beta F_y A_o \quad (5.7)$$

where P_u = ultimate load

F_u = ultimate tensile strength of the material

F_y = yield strength of the material

A_{cn} = net area of the connected leg (taking holes as 1/16 in. greater than the nominal hole size and using the $s^2/4g$ rule if necessary)

A_o = area of the outstanding leg (gross area)

$\beta = 1.0$ for connections where there are 4 or more fasteners per line or 0.5 for connections where there are 3 or 2 fasteners per line

Application of Eq. 5.7 to the test results gave a ratio of predicted load to test load of 0.96, standard deviation 0.08. Use of this equation again requires that the length of the connection (i.e., number of bolts per line in the direction of the member force) be known. Consequently, an examination was made of a large number of cases (about 1500) in an effort to provide an equation that could be used directly for design [44]. The result is a modifier to the net section, calculated in the usual way, that takes the same form as the AISC modifier U . This is—

$$A_e = UA_n \quad (5.8)$$

where A_e = effective net area, to be used in calculating the ultimate load

A_n = net area calculated in the usual way

$U = 0.80$ if the connection has 4 or more fasteners in line or 0.60 if there are 3 or 2 fasteners per line.

Using Eq. 5.8 gave prediction results nearly as good as those obtained using Eq. 5.7.

Users of the AASHTO [19] and AREA [45] specifications should be aware that the design rules for the capacity of angles connected by only one leg are somewhat different than those of AISC. The work in Reference [44] showed that the current AASHTO and

AREA specifications can overestimate the member capacity by a considerable margin in some cases.

It is recommended that Eq. 5.8 (or, the more fundamental form, Eq. 5.7) be used to calculate the ultimate strength of single or double angles when they are attached by only one leg per angle. The resistance factor $\phi = 0.75$ that is recommended for tension members (LRFD Article D1) should be applied to the result.

5.5 Block Shear

A connection can fail when a block of material shears out, as illustrated in Fig. 5.7. In part (a) of the figure, failure of a gusset plate is depicted and in part (b) a coped beam is shown. As was the situation for the problem of shear lag, the failure is not a feature related to the bolts, but is one associated with the connected material. However, it is customary to discuss both shear lag and block shear phenomena when treating the fasteners. It will be seen later that block shear failure modes observed in tests are not consistent with the idealizations shown in Fig. 5.7.

Although the label *block shear* is often used, it is intuitively obvious that the failure involves both shear stresses and tensile stresses. This is particularly evident in a connection like that illustrated in Fig. 5.7(a). It is also likely that if the region in direct tension fractures, it will be through the bolt holes, i.e., the net section. However, it is not as evident whether the regions in shear should be examined on the basis of their net section (the case shown in Fig. 5.7(a)) or simply along planes parallel to the net section in the direction parallel to the load.

Tests of gusset plates [46] show that when the net section fractures in tension, the shear action is that of yield acting along planes generally parallel to the direction of the load but not through the bolt holes. Conversely, it might be anticipated that if shear fracture takes place, it will occur through the net section of the bolt holes and the action transverse to the direction of the load will be tension yielding on the gross section transverse to the load.

The LRFD Specification use the relationship that shear yield and shear ultimate stress can be represented using the von Mises criterion, i.e., $\tau_y \approx 0.6\sigma_y$ and $\tau_u \approx 0.6\sigma_u$. The design equations are as follows:

$$\begin{aligned} \text{if } \sigma_u A_{nt} \geq (0.6\sigma_u) A_{nv} \quad \text{then} \\ P_u = \sigma_u A_{nt} + (0.6\sigma_y) A_{gv} \end{aligned} \quad (5.9)$$

$$\begin{aligned} \text{and if } (0.6\sigma_u) A_{nv} \geq \sigma_u A_{nt} \quad \text{then} \\ P_u = (0.6\sigma_u) A_{nv} + \sigma_y A_{gt} \end{aligned} \quad (5.10)$$

where the terms yet to be defined are—

A_{nt} = net area subjected to tension

A_{nv} = net area subjected to shear

A_{gt} = gross area subjected to tension

A_{gv} = gross area subjected to shear

The LRFD Specification rules are written in Article J4.3 (where the nomenclature $F_u \equiv \sigma_u$ and $F_y \equiv \sigma_y$ is used and the label is "Block Shear Rupture Strength"). Of course, the load given by Eq. 5.9 or 5.10 must be multiplied by a resistance factor. The resistance factor given in the LRFD specification for block shear is 0.75.

Equation 5.9 says that if the ultimate tensile resistance is greater than the ultimate shear resistance, then the block shear resistance of the connection is the sum of the tensile resistance (on the net section) and the shear yield resistance (on the gross shear area). Conversely, if the ultimate shear resistance is greater than the ultimate tensile resistance (Eq. 5.10), then the block shear resistance of the connection is the sum of the ultimate shear resistance (net shear area) and the tension yield force (gross cross-section).

The Commentary to the Specification says that the largest of Eq. 5.9 and 5.10 should be selected as the governing block shear strength and provides a rationale for this choice. This seems to be a holdover from an earlier edition (1986) of the Specification when the equivalent of Eq. 5.9 and 5.10 was presented without the qualifiers that now precede them. With the qualifier (the "if" statements), the user has no choice but to use the result obtained using the governing equation of the two. The Commentary statement (use the largest of Eq. 5.9 and 5.10) is in conflict.

A review of test results [46] indicates that Eq. 5.9 and 5.10 are not good predictors of the test results and, furthermore, that the failure modes seen in gusset plate connections and those in the web of coped beams are different.

There are a large number of gusset plate tests reported in the literature for which block shear is the failure mode [46]. All show that the ultimate load is reached when the tensile ductility of the gusset plate

material at the first (i.e., inner) transverse line of bolts is exhausted. This was true even in cases where oversized holes were used and in cases where the connection was short (i.e., not much shear area available). The tests show that fracture at the net tension section is reached before shear fracture can take place on the other surfaces—tensile fracture (net section) plus shear yielding takes place. Use of Eq. 5.9 and 5.10 will give conservative predictions of gusset plate strength (resistance factor taken as unity). For 36 test results, from four different sources, the LRFD equations are conservative by a factor of 1.22 (standard deviation 0.08). A better predictor of the ultimate strength of a gusset plate connection is obtained by adding the ultimate tensile strength (net tensile area) and the shear yield strength (gross shear area). This brings the predicted capacity much more closely into line with the test values [46]. For an even better estimate of strength, the proposal made in Reference [47] can be used. This model uses net section tensile strength plus a shear strength component that reflects connection length. In the limit, short connections, the strength in shear is nearly the same as that suggested here, i.e., shear yield acting on the gross shear area. It is clear that the existing AISC rule, Eq. 5.9 and 5.10, is not a satisfactory model of the tests.

The mode of failure in coped beam webs is different than that of gusset plates. Because the shear resistance is present only on one surface, there must be rotation of the block of material that is providing the total resistance. Although tensile failure is observed on the horizontal plane through the net section in the tests, as expected, the distribution of tensile stress is not uniform. Rather, higher tensile stresses are present toward the end of the web. The prediction of capacity given by Eq. 5.9 and 5.10 is significantly non-conservative when there are two lines of bolts present [46]. If only one line is present, then the prediction is non-conservative for at least some cases.

There are relatively few test results for block shear failure in coped beams [46]. However, using the available tests, a satisfactory model is obtained using a capacity

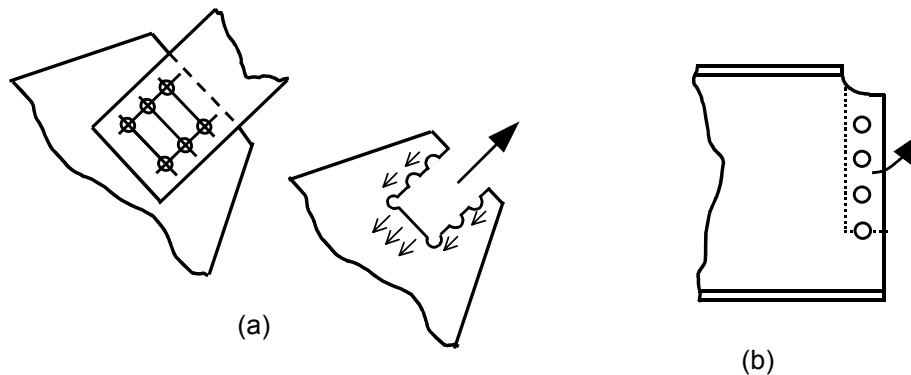

Fig. 5.7 Examples of Block Shear

equal to one-half the tensile fracture load (net section) plus the shear yield load (gross section). This was first suggested in Reference [49]. In addition, care should be taken to use generous end distances, particularly when slotted or oversize holes are present or when the bolts are distributed more-or-less from the top of the web to the bottom. If the latter detail is used, the bolt arrangement carries appreciable moment and bolt forces can produce splitting between the bolts and the end of the beam web.

Finally, there are a reasonable number of test results in which block shear took place in angles connected by one leg [46]. For this case, the use of Eq. 5.9 and 5.10 gives satisfactory results, even though the model does not work well for the gusset plate and coped beam web cases. However, the model using tensile fracture on the net tensile area and shear yielding on the gross shear area is also satisfactory.

In summary, the author recommends that the following equations be used for calculation of block shear capacity.

Gusset plates, angles:

$$R_n = A_{nt} F_u + 0.6F_y A_{gv} \quad (5.11)$$

Coped beam webs:

$$R_n = 0.5 A_{nt} F_u + 0.6F_y A_{gv} \quad (5.12)$$

A resistance factor must be applied to Eq. 5.11 and 5.12. The value $\phi = 0.75$ is suggested. Although it is likely a conservative choice, further work must be done in order to establish a more appropriate value.

Chapter 6

Bolts in Tension

6.1 Introduction

Connection configurations that place bolt groups into tension were first described in Section 1.4 (Types of Connections). In this Chapter, the connection of a tee-stub to a column flange (see Fig. 1.4(b)) will be used to discuss the issues. Two questions arise: (1) what is the relationship between the externally applied tensile load and the bolt pretension and (2) what force is carried by each bolt corresponding to the externally applied load, P .

6.2 Single Fasteners in Tension

Non-pretensioned bolts—A single bolt connecting two plates (infinitely stiff) that are loaded by an external force, P , is shown in Fig. 6.1(a). If the bolt has not been pretensioned, then the free-body diagram shown in Fig. 6.1(b) applies. This confirms that the single bolt shown must resist all of the external load that is applied to the part. The bolt simply acts like a small tension link and the least cross-sectional area should be employed to determine its capacity. Since the bolt is threaded, some reduced area (as compared with the unthreaded body portion of the bolt) must be used, and, because the thread is a spiral, the reduced area is greater than an area taken through the thread root. A notional area, the tensile stress area (A_{st}), that will accommodate this was introduced in Chapter 1 as Eq. 1.1. Hence the capacity of a single bolt that has not been pretensioned is simply the product of the tensile stress area and the ultimate tensile strength of the bolt, i.e.,

$$R_{ult} = A_{st} \sigma_u \quad (6.1)$$

If the bolt in Fig. 6.1 is preloaded, the question arises as to whether the pretension and the force in the bolt that is the result of the external loading add in some way.

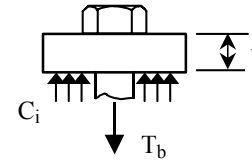

Fig. 6.2(a) Free Body: No External Load

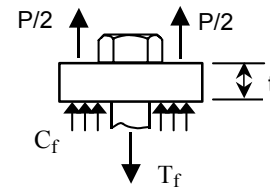

Fig. 6.2(b) Free Body: External Load Applied

Pretensioned bolts—Tightening the nut produces a tension force in the bolt and an equal compression force in the connected parts. The free-body diagram of Fig. 6.2(a) (bolt pretensioned but no external load applied) shows that

$$C_i = T_b \quad (6.2)$$

Figure 6.2(b) shows a free-body of the bolt, the adjacent plates, and an external load, P , that is applied to the connected parts. In this free-body, the tensile force in the plate and the compressive force in the plate are identified those corresponding to final conditions, T_f and C_f , respectively. The term of interest is the final bolt tension, i.e., by how much does the force in the bolt increase over its initial pretension value when the external load, P , is applied. This free-body indicates that

$$T_f = P + C_f \quad (6.3)$$

The plates and the bolt can be assumed to remain elastic,¹ and consequently the elongation of each

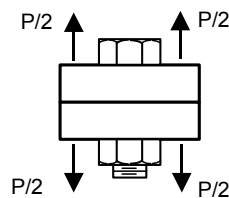

Fig. 6.1(a) Single Bolt and Tensile Force

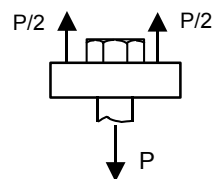

Fig. 6.1(b) Free Body Diagram

¹ The bolt will yield when pretensioning takes place, but the yielding is present only within a small portion of the total bolt volume. The assumption that the bolt is elastic is reasonable for the issue under examination.

component as the external force is applied can be calculated. The elongation of the bolt over a length equal to the thickness of one plate, t , is

$$\delta_b = \frac{(T_f - T_b)t}{A_b E} \quad (6.4)$$

As the external force is applied, the contact pressure between the plates, initially at a value C_i , decreases to some value C_f . During this process, the plate expands by an amount

$$\delta_p = \frac{(C_i - C_f)t}{A_p E} \quad (6.5)$$

where A_p is the area of plate in compression and is that associated with one fastener.

If the plates have not separated, compatibility requires that $\delta_b \equiv \delta_p$. Using Eq. 6.4 and 6.5, this means that

$$\frac{T_f - T_b}{A_b} = \frac{C_i - C_f}{A_p}$$

Using the value of C_i from Eq. 6.2 and the value of C_f that can be obtained from Eq. 6.3, and after some algebraic manipulation, the final bolt force can be obtained:

$$T_f = T_b + \frac{P}{1 + \frac{A_p}{A_b}} \quad (6.6)$$

Equation 6.6 says that the final bolt force, T_f , is the initial pretension force, T_b , plus a component of the externally applied load that depends on the relative areas of the bolt and the area of the connected material in compression. Of course, the latter is not unique and there are other assumptions in the derivation of Eq. 6.6. However, test results [50] show that Eq. 6.6 is a good predictor and that the increase in bolt pretension can be

expected to be in the order not more than about 5% to 10%.

After the parts have separated, Eq. 6.6 no longer applies and the situation is simply that corresponding to Fig. 6.1(b), i.e., the bolt must carry all of the externally applied force. In total, the response of the bolt to external load is that shown in Fig. 6.3.

The LRFD rules for the design of high-strength bolts acting in tension can now be described. The small increase in bolt force that will occur as service loads are applied is ignored. After the parts separate, the ultimate strength is that given by Eq. 6.1. The AISC LRFD Specification tabulates permissible stresses for A325 and A490 bolts in tension: it is intended that these permissible stresses be multiplied by the cross-sectional area of the bolt corresponding to the diameter. Because it is convenient for the designer to not have to calculate the stress area, the difference between this nominal area and the stress area is accommodated by use of a multiplier. For most structural bolt sizes, the relationship between the two areas is about 0.75.

The nominal tensile strength according to the LRFD Specification (Clause J3.6) is

$$R_n = 0.75 A_b F_u \quad (6.7)$$

which is a direct reflection of Eq. 6.1. The LRFD Specification requires that the resistance factor to be applied to R_n is $\phi = 0.75$. The resistance factors recommended in [22] are 0.85 and 0.83 for A325 and A490 bolts, respectively. However, these recommendations are for bolts loaded using laboratory testing machines: similar bolts in real connections could have some bending present. Nevertheless, the LRFD Specification recommendation ($\phi = 0.75$) appears to be conservative.

The remaining question, how much force is carried by a bolt in a connection of real components, is addressed in the next section.

6.3 Bolt Force in Tension Connections

In the previous section, the resistance of a single bolt to an externally applied load was identified. In this section, the effect of the externally applied load acting upon a bolt group in which tensile forces develop will be examined. The need for this examination arises because the deformation of the connected parts can produce forces in the bolts that are larger than the nominal values. For instance, the tee-stub connection shown in Fig. 6.4—which is a component of the connection shown in Fig. 1.4(b)—has four bolts connecting the flange of the tee to the column flange shown. It would normally be expected that the load per bolt is $P/4$. However, deformation of the connected parts can produce loads significantly greater than this.

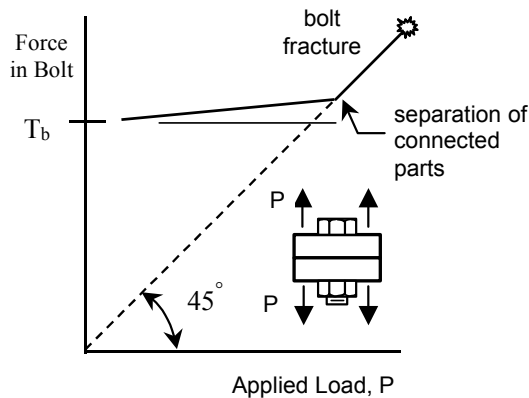

Fig. 6.3 Bolt Force vs. Applied Load

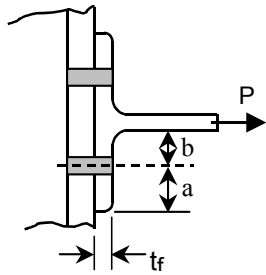

Fig. 6.4 Tee-Stub Connection

Figure 6.5 shows the tee stub in a deformed condition. The drawing exaggerates the deformation, but it identifies that the tee stub flange acts like a lever upon the bolts. This result is termed *prying action*. Obviously, the amount of prying depends upon the stiffness of the flange, among other factors. If the flange is very stiff, then the bolt force vs. applied load relationship will be like that in Fig. 6.3, which was for a single bolt loaded by an external force that acted upon an infinitely stiff part. If the flange is relatively flexible, then the relationship can be like that shown in Fig. 6.6. In addition to the stiffness of the flange, the other factors that can have the most significant effect upon the amount of prying are the bolt deformation capacity and the location of the bolt in the tee-stub flange (i.e., the dimensions a and b in Fig. 6.4).

Various models have been developed to quantify the bolt prying force. They are reviewed in Reference [6], where the model recommended is the one that was selected for use in the LRFD Manual [51]. Figure 6.7 shows the geometry of the model. It should be evident that selection of the dimension b should be as small as practicable (which will be for wrench clearance, mainly) so as to minimize the prying force, Q .

Summation of the forces gives

$$T + Q - B = 0 \quad (6.8)$$

A free-body taken from the flange tip to the centerline of the bolt (not shown) shows that

$$M_2 = Q \cdot a \quad (6.9)$$

Next, a free-body of the flange between the face of

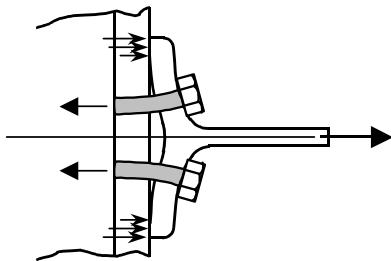

Fig. 6.5 Tee-Stub in Deformed Condition

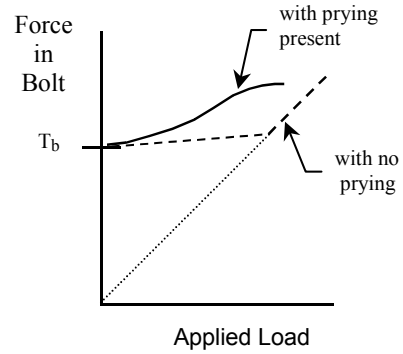

Fig. 6.6 Bolt Force vs. Applied Load, Prying Present

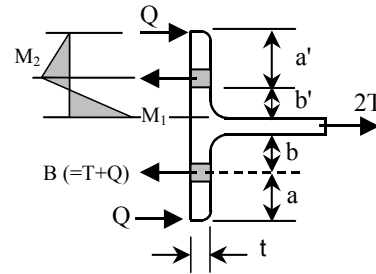

Fig. 6.7 Prying Action Nomenclature

the tee-stub web and the bolt line (Fig. 6.8) and a summation of moments gives

$$M_1 + M_2 - T \cdot b = 0 \quad (6.10a)$$

The moments M_1 and M_2 act on different cross-sections, the former on the gross cross-section of the flange and the latter on the net cross-section, i.e., a cross-section taken through the bolt holes. In order to normalize Eq. 6.10(a), the moment M_2 will be multiplied by the ratio $\delta = \text{net cross-section} / \text{gross cross-section}$. Thus, Eq. 6.10(a) should be rewritten as:

$$M_1 + \delta \cdot M_2 - T \cdot b = 0 \quad (6.10b)$$

Also, it will be convenient to describe M_2 as a fraction, α , of M_1 , where $0 \leq \alpha \leq 1.0$:

$$M_1 + \alpha \cdot \delta \cdot M_1 - T \cdot b = 0$$

Solving for the moment M_1 :

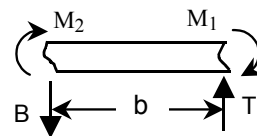

Fig. 6.8 Free-body Diagram

$$M_1 = \frac{T \cdot b}{1 + \alpha \cdot \delta} \quad (6.11)$$

Equation 6.9 can now be rewritten as

$$\alpha \cdot \delta \cdot M_1 = Q \cdot a$$

or,

$$Q = \frac{\alpha \cdot \delta}{a} M_1$$

Substitute the value of M_1 according to Eq. 6.11 to obtain the prying force

$$Q = \frac{\alpha \cdot \delta}{(1 + \alpha \cdot \delta)} \frac{b}{a} T$$

and then use Eq. 6.8 ($B = T+Q$) to obtain the final bolt force as

$$B = T \left[1 + \left(\frac{\alpha \cdot \delta}{1 + \alpha \cdot \delta} \right) \left(\frac{b}{a} \right) \right] \quad (6.12)$$

Reference [6] suggests using the dimensions a' and b' (Fig. 6.7) instead of a and b . This improves the agreement against test results and is slightly less conservative.

The result obtained using Eq. 6.12 can now be used to establish whether the bolt is adequate, in accordance with the LRFD Specification requirements (i.e., Eq. 6.7 multiplied by a resistance factor, which was also expressed as Eq. 4.1). A concomitant requirement is that the flexural strength of the tee-stub flange be adequate. The plastic moment capacity, $\phi M_p = \phi Z F_y$, is available since local buckling is not an issue. For a flange length w tributary to one bolt, this moment capacity is

$$\phi \frac{w t_f^2}{4} F_y$$

Setting this resistance equal to M_1 as given in Eq. 6.11 and solving for the flange thickness required—

$$t_f = \sqrt{\frac{4 T b}{\phi w F_y (1 + \alpha \cdot \delta)}} \quad (6.13)$$

Again, it is recommended that the dimensions a' and b' shown in Fig. 6.7 be used.

Examination of the connection strength using Eq. 6.12 and 6.13 requires knowledge of the value of α , which identifies the relationship between M_1 and M_2 . (If $\alpha = 1.0$, then there is a plastic hinge at each of the M_1 and M_2 locations (Fig. 6.7), and the prying force is a maximum. If $\alpha = 0$, then of course there is no prying action.) Information that is helpful regarding practical aspects of the use of Equations 6.12 and 6.13 is available in [51 and 52].

Often, it will be expedient to identify the plate thickness for which there will be no prying, i.e., $\alpha = 0$. If this plate thickness is acceptable in practical terms, then

of course no further action is required except to ensure that the bolt chosen is large enough to carry the force T .

The issue of prying action is particularly important when the connection is subjected to fatigue. Chapter 7 should be consulted in this case.

Chapter 7

FATIGUE of BOLTED and RIVETED JOINTS

7.1 Introduction

High-strength bolted joints are often used in new structures when repetitive loads are present. Such situations include bridges, crane support structures, and the like. In many cases, the bolts will be in shear-type connections, and experience shows that the fatigue failure mode can be present in either the gross or net cross-section of the connected material. There are no reported instances of fatigue failure of the fasteners themselves when high-strength bolts are used in shear-type connections. However, in the case of connections that place the bolts in tension a potential failure mode is indeed fatigue failure of the bolts.

The case of fatigue life of riveted connections is of interest because of the need to establish the remaining fatigue life of existing structures that were fabricated in this way. Because of corrosion, old riveted structures, especially bridges, are unlikely to have the sound rivet heads that would be necessary to sustain fatigue in the axial direction of the rivet. In such cases, the rivets should be replaced by high-strength bolts. Consequently, the only case that will be discussed here is that for riveted joints loaded in shear.

Notwithstanding the distinction set out between fatigue of rivets or bolts in shear-type connections and rivets or bolts in tension-type connections, there are situations where both shear and tension are present. These cases are often inadvertent and arise because of deformation of connected parts, or because of forces actually present but which have not been calculated by the designer. For example, a floor beam connected transversely to a girder by means of riveted or bolted web framing angles will be treated by the designer as a shear-only connection. Nevertheless, some moment will be present, particularly if the angles are relatively deep. Thus, a bolt or rivet designed only for shear will also have some tension present. This usually is not significant for strength, but it can show up as a fatigue failure in the fastener. This situation will not be treated here: the reader can obtain more information in References [53, 54].

7.2 Riveted Joints

The experimental evidence is that fatigue cracking in riveted shear splices takes place in the connected material, not in the rivet itself. Consequently, the fatigue life can be expected to be a reflection of such features as the size of the hole relative to the part, the method of hole forming (drilled, punched, or sub-punched and reamed), the bearing condition of the rivet with respect to the hole, and

the clamping force provided by the rivet. At the present time, the influences of clamping force, bearing condition, and the method of hole formation have not been examined in any systematic way. The influence of the hole size, *per se*, is not likely to be strong, as long as the hole sizes and plate thicknesses commonly used in structural practice pertain. Thus, the best data available are tests on riveted connections of proportions that are consistent with usual structural practice and are of full size, or at least large size. For the time being, the effects of clamping force, bearing condition, and hole formation must simply be part of the data pool. For this reason, and because the "defect" presented by a riveted connection is not severe, it is to be expected that the scatter of data will be relatively large.

Figure 7.1 shows the experimental data, given here using SI units. Identification of the specific sources from which the test data came can be obtained in Reference [55]. Most of the data come from tests of flexural members, and most of these were members taken from service. For those cases where members taken from service were tested, the previous stress history was examined and deemed to have been non-damaging. A few of the test results are from tension members. In the case of bending members, the moment of inertia of the cross-section included the effect of holes. For the tension members, the stress range was calculated on the net cross-section. (It is not yet clear whether this is justified. In the tests, it was observed that the fatigue cracks grew at right angles to the cross-section when staggered holes were present.)

It is usual to establish the permissible fatigue life for a welded detail as the mean of the test data less two standard deviations of fatigue life [53]. In the case of both riveted and bolted connections, however, there is a great deal of scatter in the results and the fatigue life line is selected more as a matter of judgment. Figure 7.1 shows the permissible stress range for riveted shear splices according to both the AISC LRFD specification [17] and the AASHTO Specification [19]. In both cases, the net cross-section of the member must be used to calculate the stress range.

The permissible stress range is the same (Category D) for the two specifications in the initial portion of Fig. 7.1, but there is a major difference in the long-life region. For the LRFD Specification, the horizontal dotted line in Fig. 7.1 at the stress range value of about 50 MPa (7 ksi) is the controlling feature in this region of fatigue lives greater than about 6 million cycles. The AASHTO Specification prescribes the same value, but then

effectively discounts it by a factor of 2. As seen in Fig. 7.1, the AASHTO threshold stress¹ range does not start until about 50 million cycles. The adjustment is made in order to account for the presence of occasional stress ranges greater (by a factor of 2) than those corresponding to the calculated equivalent stress range [53]. This is reasonable and is consistent with the effects of observed highway truck traffic. Thus, the threshold stress in the AASHTO Specification is one-half of that used in the LRFD Specification.

The implication of the LRFD rules, specifically the selection of the constant amplitude fatigue limit at a value of 7 ksi, is that the calculated stress ranges must be known exactly. If only a small fraction of the actual stress ranges exceed the CAFL, then fatigue cracking can take place [52]. Thus, when applying the LRFD rules, the designer must ensure that the calculated stress ranges in the long-life region will always be below the CAFL. One way of doing this is to use conservative assumptions regarding the applied forces. (As discussed above, the AASHTO Specification handles this by a two-fold increase in the fatigue load.) It can also be observed (Fig. 7.1) that there are some test data at or below the LRFD threshold limit.

7.3 Bolted Joints

High-strength bolted joints can be subdivided into two categories; those that are lap or butt splices ("shear splices") and those that are tension-type connections. In the former case, the bolts can be either pretensioned or not pretensioned, although in new construction most specifications require that the bolts be pretensioned if fatigue loading is likely. It has always been common practice in bridge construction to use pretensioned bolts.

7.3.1 Bolted Shear Splices

The fatigue strength of a bolted shear splice is directly influenced by the type of load transfer in the connection. This load transfer can be completely by friction at the interface of the connected parts (slip-critical case, pretensioned bolts), completely by bearing of the bolts against the connected material (non-pretensioned bolts), or by some combination of these two mechanisms. In the case where the load transfer is by friction, fretting of the connected parts occurs, particularly on the faying surfaces near the extremities of the joint. Here, the differential strain between the two components is highest and,

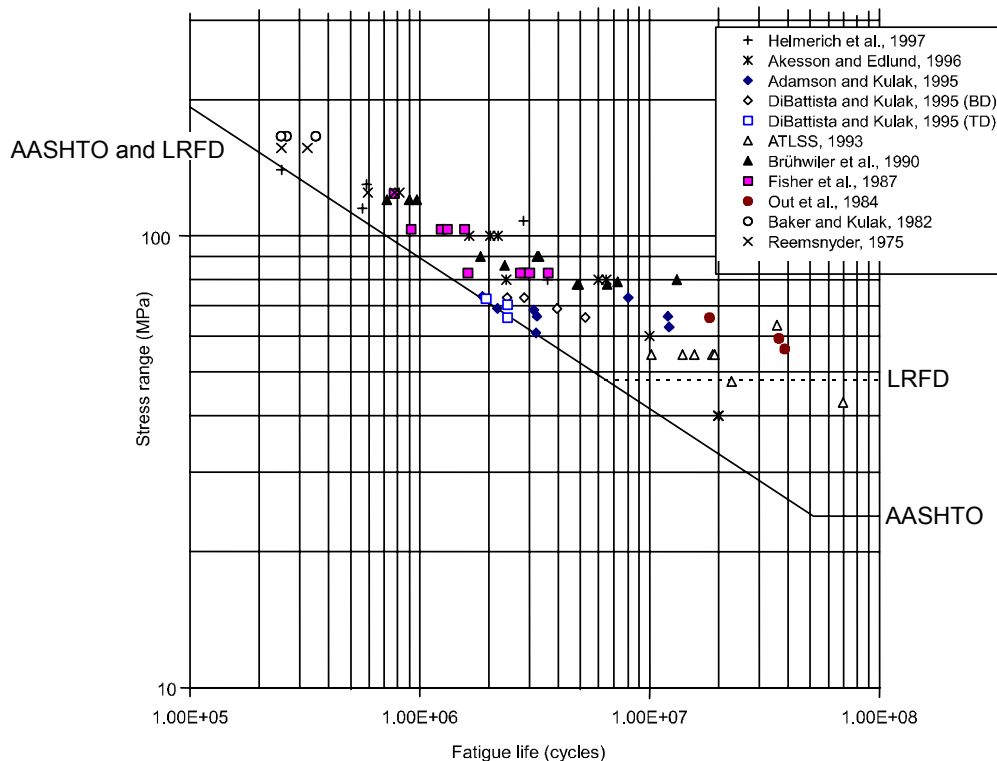

Fig. 7.1 Fatigue of Riveted Connections

¹ Also called constant amplitude fatigue limit, or CAFL, in the literature.

consequently, minute slip takes place in this location as load is applied repetitively. Cracks are initiated and grow in this region, which means that cracking takes place ahead of the first (or last) bolt hole in a line, and the crack progresses from the surface down through the gross cross-

section of the component. The phenomenon is referred to as "fretting fatigue."

If the bolts are not pretensioned, load transfer is by shear in the fasteners and an equilibrating bearing force in the connected parts. The local tensile stress in the region of the connected part adjacent to the hole is high, and this is now the location where fatigue cracks can start and grow. Some point at the edge of the hole or within the barrel of the hole is the initiation site for the fatigue crack, and growth is through the net cross-section of the connected part.

Both types of fatigue crack behavior have been observed in laboratory tests and, in a few cases, both types have been observed within the same test. If non-pretensioned bolts are used, it is highly unlikely that fretting fatigue will occur, however. When pretensioned bolts are used, it is prudent that the designer check both possible types of failure.

It is worth noting again that there is no history of fatigue failure of high-strength bolts themselves in shear splices. Only the connected material is susceptible to fatigue cracking.

The AISC LRFD Specification permissible stress range for bearing-type connections (bolts not pretensioned) is the same as it is for riveted connections, as would be expected. This can be seen in Fig. 7.1 (the sloping straight line that changes to a horizontal straight line at about 6 million cycles). The stress range must be calculated using the net section of the member. The AASHTO rule for this case also follows what was prescribed by AASHTO for riveted connections, i.e., the sloping straight line down to 50 million cycles, followed by a horizontal straight line portion. The reason for the difference in how the two specifications handle the long-life region was discussed in Section 7.2, where some cautionary comments for users of the LRFD Specification were provided.

For slip-critical splices, AASHTO prescribes Category B. In this case, the gross cross-section is used to calculate the stress range. Category B (not shown here) is a sloping straight line until it meets a horizontal straight line at 55 MPa (8 ksi). This junction is 23.6 million cycles. If the joint is high-strength bolted but not designed as slip-critical, then the net cross-section is to be used in the calculations. However, in practice it is likely that all joints in a bridge will be designed as slip-critical.

The LRFD Specification also uses Category B for slip-critical joints, but again the horizontal cut-off is twice as large as that used in AASHTO. In this case, it is 110 MPa (16 ksi), which occurs at about 3 million cycles. Selection of Category B for both LRFD and AASHTO reflects the superior fatigue life characteristics of a bolted splice that is designed as slip-critical.

There are many examples where fatigue cracking is the consequence of out-of-plane deformations [53, 54]. This is referred to as displacement-induced fatigue

cracking. The AASHTO Specification provides guidance for such situations, but the LRFD Specification is silent on this topic. Elimination of displacement-induced fatigue cracking is largely a matter of good detailing, which is a difficult thing to quantify. However, both the AASHTO Specification [19] and References [53 and 54] are helpful sources. Designers are reminded that meeting the rules for force-induced fatigue design, as has been discussed in this chapter, does not eliminate the need to examine the possibility of distortion-induced fatigue cracking.

7.3.2 Bolts in Tension Joints

Although there are few, if any, reported fatigue failures of high-strength bolted shear splices, fatigue failures of high-strength bolted tension-type connections have occurred from time to time. Fortunately, it is unusual to use tension-type connections in bridges and other repetitively structures loaded structures. The experimental data upon which to base design rules are not very numerous, however.

Connections that result in bolts in tension were illustrated in Fig. 1.4. A significant feature of the connection is that prying forces develop, and it was explained in Chapter 6 that this places an additional force in the bolt, thereby increasing the nominal tension value (i.e., the total external force divided by the number of bolts). The amount of the prying force is dependent upon the flexibility of the connection. The same flexibility introduces bending into the bolt, and this can also affect the fatigue life of the bolt. The threaded portion of the bolt provides the crack initiation location, which as a rule is at the root of a thread. It should be noted that the predictions for prying force given in Chapter 6 are based on conditions at ultimate load. The level of prying force at service load levels, which is where fatigue takes place, has not been established by either analysis or tests.

The stress range experienced by the bolt as the assembly undergoes repeated loading is significantly affected by the level of bolt pretension [6]. At one extreme, properly pretensioned bolts in a very stiff connection will undergo little or no stress range and will therefore have a long fatigue life. On the other hand, if the connection is relatively flexible, bolt bending is present, and the bolt pretension is low, then the stress range in the bolt threads will be large. Bolts in this condition will have a short fatigue life. An additional complication occurs if the applied load is high enough to produce yielding in the fasteners. In this case, it has been shown that the stress range increases with each cycle [6].

The available test data are in References [56 and 57]. Fatigue was not the primary purpose of either experimental program and the test parameters that relate to fatigue are limited. The tests did show that the actual stress range in a bolt that is properly pretensioned and where the prying forces are small is substantially smaller than the nominal stress range. (The nominal stress range

is the nominal load per bolt divided by the bolt stress area.)

The AASHTO Specification [19] requirements for bolts in tension-type connections follow the same general pattern as that for other details. However, the cases of ASTM A325 and A490 bolts in tension are not set out as separate Detail Categories. Instead, the necessary information for calculating the fatigue life of a high-strength bolt in tension is simply listed in AASHTO Tables 6.6.1.2.5-1 and 6.6.1.2.5-3. These tables provide the constant A and the constant amplitude fatigue stress for use in the AASHTO fatigue life equations. Other information concerning fatigue of bolts in tension is given in AASHTO Article 6.13.2.10.3, where, among other things, it is noted that the bolt prying force must not exceed 60% of the nominal force in the bolt. It is also pointed out that the stress range is to be calculated using the area of the bolt corresponding to the nominal diameter. This is simply a convenience that can be employed because the ratio between the area through the threads and that corresponding to the nominal diameter of the bolt is relatively constant for the usual bolt sizes.

The AASHTO rules provide a sloping straight line in the short life region, followed by a horizontal straight line at the level of the constant amplitude fatigue limit, as is usual for all AASHTO details. However, the sloping straight line portion is short and the constant amplitude fatigue limit (CAFL) governs for most cases. For both A325 and A490 bolts, the CAFL starts to govern at only about 58,000 cycles if the CAFL is taken at its tabulated value. If the CAFL is divided by 2, as was explained in Section 7.2, then the sloping straight line intersects the CAFL/2 line at 458,000 cycles. In either event, the AASHTO Specification rules capture the test data in a reasonable way. It can be observed, however, that the test data do not indicate a differentiation between A325 and A490 bolts, which is the position taken in AASHTO.

The AISC LRFD Specification [17] treats high-strength bolts in a tension connection and loaded in fatigue as a Category E' detail, except that the threshold stress is to be taken as 7 ksi (Article A-K3.4(b)). This applies to both A325 and A490 bolts, which is consistent with the test data [56, 57]. The designer has the option of (1) determining the stress range by analysis, using the relative stiffness of the various components of the connection, including the bolts, or (2) by simply taking 20% of the absolute value of the service load. (The stress range is to be calculated on the tensile stress area of the bolt.) Given the difficulty of calculating the stress range, it is likely that designers will use the second option.

In the usual range of interest, say, for >300,000 load cycles, the AISC Specification 20% rule will give predictions (permissible stress range for a given number of cycles) that are significantly conservative. A better prediction for the available test data could be obtained using a fatigue life slope that is much less than the value

of -3 used in the AISC Specification. Such a choice would be more like that taken in the AASHTO Specification.

The fatigue design of high-strength bolts that are in tension-type connections should reflect the following guidelines:

- Whenever possible, redesign the connection so that the bolts are in shear, not tension.
- Ensure that proper installation procedures are followed so that the prescribed bolt pretensions will be attained.
- Design the connection so that prying forces are minimized. The AISC Specification is silent as to how much prying force is permitted. The AASHTO rules limit the calculated prying force to 60% of the externally applied load and the RCSC Specification [14] says that the limit should be 30%. The writer recommends that calculated prying be no more than 30% of the externally applied force.

Chapter 8

SPECIAL TOPICS

8.1 Introduction

There are a number of issues that may be of interest to designers but which do not warrant an extensive discussion here because of the amount of detail involved. The specifics can be obtained more expeditiously by reviewing the relevant specifications as required. The miscellaneous subjects include the need for washers, use of oversized or slotted holes, use of particularly short or particularly long bolts, galvanized bolts and nuts, reuse of high-strength bolts, joints that combine bolts and welds, and coated faying surfaces. The short discussions that follow are intended mainly to alert the designer to the issues involved and to potential problems.

8.2 Use of Washers in Joints with Standard Holes

The AISC LRFD Specification [17] depends upon the specification of the Research Council on Structural Connections (RCSC) [14] for most matters associated with high-strength bolts and their installation. The RCSC Specification requires that a standard, hardened washer, ASTM F436 [16] be used under the turned element when calibrated wrench pretensioning or twist-off type bolt pretensioning is to be used. (A washer is not required under the non-turned element for these cases.) This requirement reflects the need to have a hard, non-galling surface under the turned element when installation is based on measurement of torque.

A washer is also required for the installation of bolts that use washer-type direct tension indicators (DTI's). Although this is not a torque-controlled method of installation, there are reasons specific to the way this installation is performed that means that washers are usually required. These reasons include the necessity that the protrusions on the DTI washer bear against a hardened surface and the need to prevent the protrusions on the DTI washer from wearing down by scouring, as could be the case if a nut or bolt head is turned directly against the protrusion side of a DTI washer. Washers are not required when the DTI washer is placed against the underside of the bolt head if the head is not turned, however. Specific information as to the location of the washer can be obtained in Article 6.2.4 of the RCSC Specification. Another helpful source for identifying washer locations when DTI's are used (and other similar bolting detail information) is Reference [58].

When snug-tightened joints are used, washers are not required, except as noted below. Likewise, for pretensioned or slip-critical joints, washers are not required if the installation is by the turn-of-nut method. There are certain exceptions, and these are noted as follows:

- If sloping surfaces greater than 1:20 are present, an ASTM F436 bevelled washer must be used to compensate for the lack of parallelism. This applies to all methods of bolt installation and all joint types.
- It is also required that washers be present when A490 bolts are used to fasten material that has a yield strength less than 40 ksi. This is because galling in the connected material under the nut can occur when softer material is fastened by these bolts. However, the only steel grade likely to fall into this category is ASTM A36, and this is used less and less for steel shapes. It is still used for angles and plates, however.
- Washers are often required for joints that use slotted or oversized holes, regardless of the type of joint or method of installation. This is discussed in Section 8.3.

Fastener components are typically supplied by the manufacturer or distributor as separate items, i.e., bolts, nuts, and washers. Assembly of the components into "sets" is sometimes done at this point in order to make it convenient for the installer of the assembly. If washers are not, in fact, required by the specifics of the application, using these washers means that the time required to place the bolts will be slightly increased because of the extra handling required in the installation. On the other hand, using washers throughout a job means that the erector does every joint in a consistent manner. If this is the method chosen, it is at least worthwhile that the inspection process reflect whether washers were actually needed.

8.3 Oversized or Slotted Holes

The use of oversized or slotted holes can be of great benefit to erectors because their use allows more tolerance when placing the components of the assembly. The question to be addressed here is the effect that oversized or slotted holes might have upon the expected performance of the connection.

The standard hole size for high-strength bolts is 1/16 in. greater than the nominal diameter of the bolt to be used. Particularly in joints that have many bolts, it is possible that not all holes in one component will line up exactly with the holes in the mating material. However, if oversized holes are used, omni-directional tolerance exists. If slotted holes are used, a greater tolerance is provided than for oversized holes, but this tolerance is mainly in one direction, the direction of the slot. The effect of oversized or slotted holes upon net section is

taken into account directly in the design calculations because the oversized hole or slot dimensions will be used. Therefore, the concern becomes one relating to the bolt behavior—will the bolt in a slotted hole or an oversized hole be reduced in capacity as a consequence.

For the case of snug-tightened joints only, when slotted or oversized holes are used in an outside ply, either an ASTM F436 washer or a 5/16 in. thick common plate washer is required.

If the joint is either pretensioned or slip-critical, then washer requirements reflect the fact that intended bolt pretensions may not be attained with standard washers. Tests have shown that both oversized and slotted holes can significantly affect the level of preload in the bolt when standard installation procedures are used. Consider an oversized hole, for example. As a hole becomes larger relative to the bolt diameter, the amount of material remaining to react the force in the bolt is reduced. Consequently, the connected material around the periphery of the hole is under higher contact stresses than would otherwise have been the case. This is exacerbated if the bolt head, nut, or washer actually scours the connected material. The situation is similar when slotted holes are used. As a result, the amount of bolt elongation (and, pretension) for a given turn-of-nut will be less than if a standard hole were present.

Tests have shown that using standard washers, which are 5/32 in. thick¹, often does not permit the expected bolt pretensions to be attained when oversized or slotted holes are used. A greater washer thickness (i.e., stiffness) is required to bridge the opening and enable the delivery of normal pretensions. The RCSC Specification does permit F436 washers for a certain number of cases—all diameters of A325 bolts and A490 bolts ≤ 1 in. diameter when oversized or short-slotted holes are present in the outer plies of a joint. However, when a long-slotted hole is used in the outer ply, a 5/16 in. thick plate washer or continuous bar is required. For the case of A490 bolts >1 in. diameter and oversized or short-slotted holes in an outer ply, an ASTM F436 washer with 5/16 in. thickness is required. If the A490 bolt is used when a long-slotted hole is present in the outer ply, then a 5/16 in. thick hardened plate washer or hardened continuous bar is required. It should be noted that, in all cases, building up to a required thickness by simply stacking standard washers is not sufficient. The requirement to be met is one of stiffness, not thickness *per se*.

¹ ASTM A436 washers have a maximum permitted thickness of 0.177 in. for all bolt diameters, but the minimum permitted thickness is a function of the bolt diameter. A reasonable average value for the thickness is usually taken as 5/32 in. (0.156 in.).

8.4 Use of Long Bolts or Short Bolts

Long or short bolts not required to be pretensioned do not require special attention. However, when pretension is required, the use of particularly long or short bolts should be scrutinized.

The bulk of the research used initially to formulate the rules for the installation of high-strength fasteners was done using bolts where the length was generally in the range from about 4 bolt diameters up to about 8 diameters [6]. Subsequently, it was found that if the bolts were shorter than this, then the installation process could produce torsional failure of the bolts or thread stripping before installation had been completed. At the other end of the spectrum, the use of long bolts means that more elastic relaxation will be present and this may degrade the pretension. For very long bolts, there simply is not enough research background for satisfactory standard pretensioning and installation rules to be set forth and preinstallation testing is required. Again, these concerns about short or long bolts apply only when pretension is required.

The RCSC Specification requires that short bolts required to be pretensioned according to the turn-of-nut process be given 1/3 turn instead of the usual 1/2 turn. This applies to bolts whose length is up to 4 diameters. If other methods of installation are chosen, e.g., calibrated wrench, use of direct tension indicating washers, or tension-control bolts, then the length effect will be captured in the preinstallation testing. A problem can arise with particularly short bolts, such as may be used in tower construction, however. Depending on the size of the Skidmore-Wilhelm calibrator, it may not be possible to properly fit the bolt into the calibrator. Either new fittings must be used to adapt the calibrator to the short bolts, or calibrated direct tension indicating washers be used, or a solid block device that measures load using strain gages can be improvised.

In the case of long bolts that must be pretensioned, if the turn-of-nut method is used and the bolts are between 8 diameters and 12 diameters, then 2/3 turn should be used. Bolts greater than 12 diameters long have not been subjected to sufficient testing to establish rules. For long bolts that will be installed by calibrated wrench or by use of direct tension indicating washers or as tension-control bolts, calibration using the Skidmore-Wilhelm device is easily accomplished by the addition of solid material sufficient to increase the grip length.

8.5 Galvanized Bolts

In order to provide corrosion protection, it is sometimes advantageous to apply a zinc coating to structural steel, i.e., to galvanize the material. In these cases, it is usually the practice to use galvanized fasteners as well. In ordinary conditions, the high-strength bolts themselves do not exhibit very much corrosion, and it is generally

unlikely that corrosion protection of the bolts is necessary for most building construction unless there is exposure to a marine atmosphere. The industrial atmosphere of some plants may make it desirable to galvanize high-strength bolts in these cases also. In no instance should A490 bolts be galvanized, however, because their high strength then makes them susceptible to hydrogen embrittlement.

The effects of galvanizing A325 bolts is discussed in this section. The effect of galvanizing the connected material is examined in Section 8.8.

The issues raised when a bolt and nut are galvanized include any possible effect on the strength properties of the bolt, the potential for nut stripping because of thread overtapping, and the influence of the zinc coating on the torque required for installation.

Research has shown that galvanizing has no effect on the strength properties of the bolt [6].

The friction between the bolt and nut threads is increased when a bolt and nut are galvanized. The galvanizing has two effects. First, it increases the variability of the relationship between applied torque and resultant pretension. At the extreme, a galvanized bolt and nut can twist off before the desired pretension has been attained. Second, thread stripping can occur before installation is complete as a result of large friction forces. In order to identify and resolve any potential problems resulting from galvanizing, ASTM A325 requires that the nut be lubricated and that the assembly be tested to ensure that stripping will not occur at a rotation in excess of that which is required in installation or that twist-off will not take place before the installation is complete.

Overtapping of the nut will usually be done by the manufacturer in order that the coated nut and coated bolt will still assemble properly. This can also be a source of thread stripping. Compliance of the assembly with the rotation test required by the A325 specification will certify that the delivered assembly will perform satisfactorily.

Compliance with all of the relevant requirements of both ASTM A325 and the RCSC Specification will ensure that galvanized bolts and nuts will give satisfactory performance. These requirements include; (1) the galvanized bolts and nuts and washers, if required, must be treated as an assembly, (2) the nuts must have been lubricated and tested with the supplied bolts, (3) the nuts and bolts must be shipped together in the same container, and (4) the supplier is not permitted to supply bolts and nuts that came from different manufacturing sources.

8.6 Reuse of High-Strength Bolts

Occasionally, a bolt that has been installed during the erection process has to be removed and then later reinstalled. This need for reinstallation of bolts might also come up if a structure is taken down and re-erected in a new location. The question arises as to whether high-

strength bolts that are required to be pretensioned can be reused, and, if so, how many times.

A certain amount of yielding takes place when a high-strength bolt is installed so that the minimum required pretension is equaled or exceeded. Yielding is confined to a relatively small volume of material located in the threaded region just under the nut. This small amount of yielding is not detrimental to the performance of the bolt [6]. However, if the bolt pretension is subsequently decreased to zero, e.g., the bolt is loosened, then the question arises as to whether it can be reused.

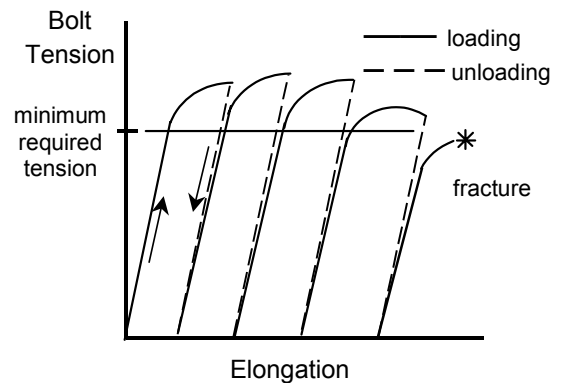

Fig. 8.1 Repeated Installation

The cycle of pretensioning, loosening, and then pretensioning again means that a certain amount of ductility is given up during each cycle. If the number of tightening and loosening cycles is large, then enough ductility will be exhausted so that, eventually, the desired pretension cannot be reached before fracture takes place. Figure 8.1 shows this effect diagrammatically. In the illustration, the minimum required tension was attained upon installation followed by three re-installations (turn-of-nut), but fractured on the fifth attempt.

The research has shown [6] that both A325 and A490 bolts can be reused a small number of times if the water-soluble oily coating that is usually applied during the manufacturing process is present. The tests on A325 bolts showed that at least three or four reinstallations were successful. However, the tests on A490 bolts showed that sometimes only one or two reinstallations were attainable.

The RCSC Specification forbids the reuse of both A490 bolts and galvanized A325 bolts. The number of reuses permitted for "black" A325 bolts can be established for a given lot by carrying out a calibration procedure using a Skidmore-Wilhelm calibrator. Of course, the number of reuses must be carefully monitored. As a rule of thumb, if the nut can be made to run freely on the threads by hand only, then reuse is permissible.

It should also be noted that either A325 or A490 bolts that have been snugged and then subsequently found to be loose can be routinely installed as pretensioned bolts. This

does not constitute a reuse since thread yielding will not have taken place. Even touch-up of pretensioned bolts in a multi-bolt joint should not generally constitute a reuse, unless the bolt has become substantially unloaded as other parts of the joint are bolted.

8.7 Joints with Combined Bolts and Welds

It is sometimes necessary to use high-strength bolts and fillet welds in the same connection, particularly when remedial work needs to be done. When these elements act in the same shear plane, the combined strength is a function of whether the bolts are snug-tightened or are pretensioned, the orientation of the fillet welds with respect to the direction of the force in the connection, and the location of the bolts relative to their holes. The AISC LRFD Specification provides recommendations for the design of such connections in Article J1.9. However, recent research [59, 60] has shown that these recommendations do not give a good prediction of the actual strength of bolted-welded connections. Although using existing LRFD rules will give conservative results, they are not based on a rational model.

The approach outlined in [59 and 60] recommends that the joint design strength be taken as the largest of the (1) shear capacity of the bolts only, (2) shear capacity of the welds only, or (3) shear capacity of the combination consisting of the fillet welds and the bolts. High-strength bolts both pretensioned and snug-tight have been explored in the research.

Based on the results of tests of the various combinations, the capacity of a combination of high-strength bolts and fillet welds placed longitudinally with respect to the force, Reference [60] recommends that

$$P_n = (0.50 \times \text{bolt shear resistance}) \\ + (\text{long. weld shear resistance}) \\ + (0.25 \times \text{slip resistance}) \quad (8.1)$$

The bolt shear resistance, the longitudinal weld shear resistance, and the slip resistance are all calculations that are to be made in accordance with the LRFD Specification, including the resistance factors (which are not shown in Eq. 8.1).

If bolts and transversely oriented fillet welds are combined, then the capacity is to be taken as

$$P_n = \text{transverse weld shear resistance} \\ + (0.25 \times \text{slip resistance}) \quad (8.2)$$

where the transverse weld shear resistance is now used. Because the amount of deformation that can be accommodated by a transverse fillet weld prior to fracture is very small, the contribution of the bolts in shear is negligible, and is taken here as zero. Once the transverse weld has reached its ultimate capacity (i.e., when it

fractures), then the situation simply reverts to that of a bolted joint. This strength may be greater than that given by Eq. 8.2, depending on the proportion of bolts to transverse weld.

When bolts are combined with both longitudinal and transverse welds, the capacity is to be taken as

$$P_n = (0.85 \times \text{long. weld shear resistance}) \\ + (\text{transverse weld shear resistance}) \\ + (0.25 \times \text{slip resistance}) \quad (8.3)$$

Once again, it is recognized that the transverse weld will reach its ultimate strength at a relatively small amount of deformation. Once it breaks, the situation reverts to that of a longitudinal fillet weld in combination with high-strength bolts. Now, Eq. 8.1 applies and the strength calculated in this way could be larger than that obtained using Eq. 8.3.

Overriding all these cases, it has already been noted that it is possible that the weld shear strength alone can govern or that the bolt shear strength alone can govern. The practical meaning of such a situation is that there can be no benefit when considering certain combinations of bolts and welds. These cases will arise when the proportions of welds and bolts are inappropriate. Consider, for example, an existing bolted joint to which only a small amount of longitudinal weld is added. As the joint is loaded, the bolts are not fully effective in shear, according to Eq. 8.1. As the longitudinal weld reaches its ultimate capacity and fractures, the situation reverts to that of a bolted joint alone. The bolts are now fully effective and their strength can be greater than the combined bolted-welded strength. In total, the designer has to check these situations (bolts alone or welds alone) plus the appropriate equations among Eq. 8.1, 8.2, and 8.3.

Generally, the addition of transverse fillet welds to a bolted joint is not an very effective way of strengthening an existing joint.

8.8 Surface Coatings

In some applications, it is advisable to provide a protective coating to the surface of the steel used in the structure. The main reason for doing so is to prevent corrosion of the steel, either for when the steel is exposed during the erection phase or for protection on a continuing basis. Coatings can be paint, a metallic layer of zinc or aluminum, various kinds of vinyl washes, organic or inorganic zinc-rich paints, and so on. If the coating is applied to the surfaces of joints that are designated as snug-tightened or as pretensioned [14, 17], then the coating has no influence upon the strength or performance of the connection. In these cases, the strength of the joint is determined on the basis of the net section of the connected material, on the shear strength of the bolts, or on the bearing strength of the connected material. It is

only when the joint is designated and designed as slip-critical that the coating plays a role.

The design of slip-critical joints was described in Section 5.2. As explained there, the designer has the option of designing on the basis of factored loads or by using the nominal loads. If factored loads are used, then the slip coefficient of the steel, μ , enters directly into the design equation (Eq. 5.2). In the LRFD Specification, faying surfaces are categorized as A, B, or C, and values are given for the slip coefficient for these surfaces. For example, a hot-dip galvanized surface that has been roughened (by light hand wire brushing) is a Class C surface and a slip value $\mu = 0.35$ is prescribed. In all other cases where coatings are used, it is required that tests be carried out to determine the slip coefficient for that case. The method of test is given in the RCSC Specification [14].

If the designer proceeds on the basis of nominal loads, then the expression for the slip resistance is expressed in terms of an equivalent shear stress (see Section 5.2). The LRFD expression in this case is based on the use of $\mu = 0.33$, which is the slip coefficient for an unpainted clean mill scale surface. However, the designer has the opportunity here also to use other values by adjusting the permissible equivalent shear stress to reflect different slip coefficients, as obtained from the literature or by tests.

REFERENCES

1. Bibliography on Bolted and Riveted Joints, ASCE Manuals and Reports on Engineering Practice, No. 48, American Society of Civil Engineers, Reston, VA.,
2. Bibliography on Riveted Joints, A.E.R. deJong, American Society of Mechanical Engineers, New York, 1945.
3. C. Batho and E.H. Bateman, "Investigations on Bolts and Bolted Joints, Second Report of the Steel Structures Research Committee," London, 1934.
4. W.M. Wilson and F.P. Thomas, "Fatigue Tests on Riveted Joints," Bulletin 302, Engineering Experiment Station, University of Illinois, Urbana, 1938.
5. Research Council on Riveted and Bolted Structural Joints of the Engineering Foundation, Specifications for Assembly of Structural Joints Using High-Strength Bolts, 1951.
6. G.L. Kulak, J.W. Fisher, and J.A.H. Struik, *Guide to Design Criteria for Bolted and Riveted Joints*, Second Edition, John Wiley, New York, 1987.
7. *Connections in Steel Structures: Behaviour, Strength, and Design*, Elsevier Applied Science, 1988, Editors: Reidar Bjorhovde, Jacques Brozzetti, and Andre Colson
8. *Connections in Steel Structures II: Behavior, Strength, and Design*, American Institute of Steel Construction, 1991. Editors: Reidar Bjorhovde, Andre Colson, Geerhard Haaijer, and Jan Stark.
9. *Connections in Steel Structures III: Behaviour, Strength, and Design*, Pergamon, 1996. Editors: Reidar Bjorhovde, Andre Colson, and Riccardo Zandonini.
10. ASTM A502-93, Standard Specification for Steel Structural Rivets, American Society for Testing and Materials, West Conshohocken, Pennsylvania, USA.
11. ASTM A307-00, Standard Specification for Carbon Steel Bolts and Studs, 60 000 PSI Tensile Strength, American Society for Testing and Materials, West Conshohocken, Pennsylvania, USA.
12. ASTM A325-00, Standard Specification for Structural Bolts, Steel, Heat Treated, 102/105 ksi Minimum Tensile Strength, American Society for Testing and Materials, West Conshohocken, Pennsylvania, USA.
13. ASTM A490-00, Standard Specification for Heat-Treated Steel Structural Bolts, 150 ksi Minimum Tensile Strength, American Society for Testing and Materials, West Conshohocken, Pennsylvania, USA.
14. Load and Resistance Factor Design Specification for Structural Joints Using ASTM A325 or A490 Bolts, Research Council on Structural Connections, 2000. (Available free at www.boltcouncil.org).
15. ASTM A563-00, Standard Specification for Carbon and Alloy Steel Nuts, American Society for Testing and Materials, West Conshohocken, Pennsylvania, USA.
16. ASTM F436-93(2000), Standard Specification for Hardened Steel Washers, American Society for Testing and Materials, West Conshohocken, Pennsylvania, USA.
17. Load and Resistance Design Specification for Structural Steel Buildings, American Institute of Steel Construction, Chicago, Illinois, 1999.
18. Specification for Structural Steel Buildings, Allowable Stress Design and Plastic Design, American Institute of Steel Construction, Chicago, Illinois, 1989.
19. AASHTO LRFD Bridge Design Specifications – US, 2nd Edition, American Association of State Highway and Transportation Officials, Washington, D.C., 1998.
20. *Load and Resistance Factor Design of Steel Structures*, Louis F. Geschwindner, Robert O. Disque, and Reidar Bjorhovde. Prentice-Hall 1994.
21. L. Shenker, C.G. Salmon, and B.G. Johnston, "Structural Steel Connections," Department of Civil Engineering, University of Michigan, Ann Arbor, 1954.
22. Fisher, J.W., Galambos, T.V., Kulak, G.L., and Ravindra, M.K., "Load and Resistance Factor Design Criteria for Connectors," J. of the Structural Division, ASCE, Vol. 104, No. ST9, September 1978.
23. Munse, W.H. and Cox, H.C., "The Static Strength of Rivets Subjected to Combined Tension and Shear," Engineering Experiment Station Bulletin 427, University of Illinois, Urbana, 1956.
24. Hechtman, R.A., "A Study of the Effects of Heating and Driving Conditions on Hot-Driven Structural Steel Rivets," Department of Civil Engineering, University of Illinois, Urbana, 1948.

25. Yoshida, N. and Fisher, J.W., "Large Shingle Splices that Simulate Bridge Joints," Fritz Engineering Laboratory Report No. 340.2, Lehigh University, Bethlehem, PA, December, 1968.
26. Higgins, T.R. and Munse, W.H., "How Much Combined Stress Can a Rivet Take?" Engineering News-Record, December 4, 1952.
27. Rumpf, John L. and Fisher, John W., "Calibration of A325 Bolts," J. of the Structural Division, ASCE, Vol. 89, ST6, December, 1963.
28. Christopher, R.J., Kulak, G.L., and Fisher, J.W., "Calibration of Alloy Steel Bolts," J. of the Structural Division, ASCE, Vol. 92, ST2, April, 1966.
29. Bickford, John H., "An Introduction to the Design and Behavior of Bolted Joints," Second Edition, Marcel Dekker Inc., New York, 1990.
30. Kulak, G.L. and Birkemoe, P.C., "Field Studies of Bolt Pretension," J. Construct. Steel Research, Vol. 25, Nos. 1 & 2, pages 95-106, 1993.
31. ASTM F1852-00, Standard Specification for "Twist Off" Type Tension Control Structural Bolt/Nut/Washer Assemblies, Steel, Heat Treated, 120/105 ksi Minimum Tensile Strength, American Society for Testing and Materials, West Conshohocken, Pennsylvania, USA.
32. Kulak, Geoffrey L. and Undershute, Scott T., "Tension Control Bolts: Strength and Installation," Journal of Bridge Engineering, Vol. 3 No. 1, ASCE, February, 1998.
33. ASTM F959-99a, Standard Specification for Compressible-Washer-Type Direct Tension Indicators for Use with Structural Fasteners, American Society for Testing and Materials, West Conshohocken, Pennsylvania, USA.
34. Dahl, Joan S., Le-Wu Lu, Fisher, John W., and Abruzzo, John, "Comparative Effectiveness of Tightening Techniques for A490 1-1/4 in. Diameter Bolts," Engineering Journal, American Institute of Steel Construction, Vol. 33, No. 1, First Quarter, 1996.
35. Oswald, C.J., Dexter, R.J., Brauer, S.K., "Field Study of Pretension in Large Diameter A490 Bolts," ASCE Journal of Bridge Engineering, Vol. 1, August, 1996.
36. Mikkel A. Hansen, "Influence of Undeveloped fillers on Shear Strength of Bolted Splice Joints," PSFSEL Thesis No. 80-1, Department of Civil Engineering, The University of Texas at Austin, March, 1980.
37. Yura, J.A., Frank, K.H., and Polyzois, D., "High Strength Bolts for Bridges," PMFSEL Report No. 87-3, Department of Civil Engineering, The University of Texas at Austin, May, 1987.
38. Chesson, Eugene, Jr., Munse, William H., and Faustino, Norberto R., "High-Strength Bolts Subjected to Tension and Shear," Journal of the Structural Division, ASCE, Vol. 91, ST5, October, 1965.
39. Chesson, Eugene, Jr., "Bolted Bridge Behavior During Erection and Service," Journal of the Structural Division, ASCE, Vol. 91, ST3, June, 1965.
40. European Committee for Standardisation, Eurocode 3 : Design of Steel Structures, ENV, 1993-1-1, 1992, Brussels.
41. Frank, K.H. and Yura, J.A., "An Experimental Study of Bolted Shear Connections," Report No. FHWA/RD-81/148, Federal Highway Administration, Washington, D.C., December 1981.
42. Munse, W.H. and Chesson, E. Jr., "Riveted and Bolted Joints: Net Section Design," J. of the Struct. Div., ASCE, Vol. 89 (1), 107-126, 1963.
43. Chesson, E., Jr., and Munse, W.H., "Riveted and Bolted Joints: Truss Type Tensile Connections," J. of the Struct. Div., ASCE, Vol. 89 (1), 67-106, 1963.
44. Kulak, Geoffrey L. and Wu, Eric Yue, "Shear Lag in Bolted Tension Members," J. of Structural Engineering, ASCE, Vol. 123, No. 9, Sept. 1997.
45. American Railway Engineering and Maintenance of Way Association (2002). "Steel Structures," Chapter 15, Manual for Railway Engineering, AREMA, Landover, MD.
46. Kulak, Geoffrey L. and Grondin, G.Y., "AISC LRFD Rules for Block Shear in Bolted Connections—A Review," Engineering Journal, American Institute of Steel Construction, Vol. 38, No. 4, Fourth Quarter, 2001. (See also Errata to this reference.)
47. Hardash, Steve and Bjorhovde, Reidar, "New Design Criteria for Gusset Plates in Tension," Engineering Journal, American Institute of Steel Construction, Vol. 2, No. 2, Second Quarter, 1985.
48. Yura, J.A., Birkemoe, P.C. and Ricles, J.M., "Beam Web Shear Connections: An Experimental Study," J. of the Structural Division, ASCE, Vol. 108, No. ST2, February, 1982.
49. Ricles, J.M. and Yura, J.A., "Strength of Double-Row Bolted-Web Connections," J. of the Structural Division, ASCE, Vol. 109, No. 1, January, 1983.
50. McGuire, William, "Steel Structures," Prentice-Hall Inc., Englewood Cliffs, N.J., 1968.

51. American Institute of Steel Construction, "Manual of Steel Construction, Load and Resistance Factor Design," Third Edition, Chicago, 2001.
52. Thornton, William A., "Prying Action—A General Treatment," Engineering Journal, American Institute of Steel Construction, Vol. 2, No. 2, Second Quarter, 1985.
53. Fisher, J.W., Kulak, G.L., and Smith, I.F.C., "A Fatigue Primer for Structural Engineers," National Steel Bridge Alliance, American Institute of Steel Construction, Chicago, IL., 1998.
54. Fisher, J.W., Yen, B.T. and Wang D., "Fatigue of Bridge Structures – a Commentary and Guide for Design, Evaluation and Investigation Of Cracking," ATLSS Report No 89-02, Lehigh University, Bethlehem, PA, 1989.
55. Kulak, G.L., "Fatigue Strength of Riveted Shear Splices," Progress in Structural Engineering and Materials, Vol 2 (1), 1–10, 2000.
56. Nair, R.S., Birkemoe, P.C., and Munse, W.H., "High Strength Bolts Subjected to Tension and Prying," J. of the Structural Division, ASCE, Vol. 100, No. ST2, February, 1974.
57. Bouwman, L.P., "Fatigue of Bolted Connections and Bolts Loaded in Tension," Report No. 6–79–9, Stevin Laboratory, Delft Univ. of Technology, Delft, The Netherlands, 1979.
58. Structural Bolting Handbook, Steel Structures Technology Center, Inc. Novi, MD., 1999.
59. Manuel, Thomas J. and Kulak, Geoffrey L., "Strength of Joints that Combine Bolts and Welds," Journal of Structural Engineering, ASCE, Vol. 126, No. 3, March, 2000.
60. Kulak, G.L. and Grondin, G.Y., "Strength of Joints that Combine Bolts and Welds," accepted for publication, Engineering Journal, American Institute of Steel Construction.

INDEX

- Allowable stresses, 6
- Anchor rods (anchor bolts), 2
- American Institute of Steel Construction (AISC)
 - Allowable stress design, 7
 - LRFD Specification, 6
- American Society for Testing and Materials (see ASTM)
- Arbitration inspection, 21
- ASTM (bolt and related specifications)
 - A307, 3
 - A325, 3, 13
 - A354BD, 4
 - A449, 4
 - A490, 3, 13
 - A502, 2
 - F436, 45
 - F1852, 13, 45
- Bearing
 - bearing stresses, 6, 31
- Bearing-type joints, 6, 30, 31
- Block shear, 34
- Bolts
 - Bolt length, 46
 - Combined shear and tension, 25
 - Combined with welds, 48
 - Fatigue strength, 42
 - High-strength, 3
 - Installation (see Installation of bolts)
 - Mechanical properties, 3, 13
 - Ordinary, or, common (A307), 3
 - Pretension (see Pretension)
 - Reuse, 47
 - Shear strength, 24
 - Tensile strength, 23, 37
- Butt splice, 27
- Calibrated wrench installation, 17
- Calibration of bolts, 17
- Clamping force (see pretension)
- Coatings, 48
- Combined bolted-welded joints, 48
- Combined tension and shear, 10, 25
- Common bolts (A307), 3
- Connections
 - Butt splice, 27
 - Gusset plate, 4
 - Tension-type, 5
- Design philosophy, 6
- Direct tension indicators, 19, 45
- End distance, 31
- Fatigue
 - AASHTO specification, 44
 - AISC specification, 44
 - Fretting, 42
 - Riveted connections, 41
 - Shear-type bolted connections, 42
 - Tension-type bolted connections, 43
- Galvanized bolts and nuts, 46, 48
- Grip length, 16, 46
- High-strength bolts
 - ASTM A307, 3
 - ASTM A325, 3, 13
 - ASTM A354BD, 4
 - ASTM A449, 4
 - ASTM A490, 3
 - ASTM F1852, 45
 - Direct tension strength, 23, 37
 - Galvanized, 46
 - Historical review, 1
 - Installation (see Installation of bolts)
 - Load vs. deformation in shear, 24
 - Load vs. deformation in tension, 23
 - Mechanical properties, 3, 13
 - Reuse (reinstallation), 47
 - Shear strength, 24
 - Tension control bolts, 18
 - Torqued tension, 14
- Holes
 - Oversize holes, 45
 - Slotted holes, 45
- Inspection
 - Arbitration, 21
 - Direct tension indicators, 21
 - General requirements, 20
 - Pretensioned bolts, 21
 - Snug-tightened bolts, 21
 - Twist-off bolts, 21
- Installation of bolts
 - Calibrated wrench, 17
 - General requirements, 13
 - Load-indicating washers, 19
 - Tension-control bolts, 18
 - Turn-of-nut, 14
 - Washers, 16, 45
- Joint length effect, 27
- Joint type (shear splices)
 - Pretensioned bolts, 20
 - Slip-critical, 20
 - Snug-tightened bolts, 20
- Lap splice, 4
- Limit states, 6, 7
- Load and Resistance Factor Design (LRFD), 7
- Load factor, 7
- Load indicating washers, 19
- Load transfer concepts, 4

- Mechanical fasteners
 - Bolts, 3
 - Rivets, 1
- Nuts
 - Galvanized, 47
 - Specifications, 4
- Oversize holes, 45
- Pretension
 - Calibrated wrench installation, 17
 - Direct tension indicators, 19
 - Effect of bolt length, 16, 46
 - Effect of external load, 37
 - Effect of hole size, 45
 - High-strength bolts, 4, 13, 15
 - Load-indicating washers, 19
 - Ordinary bolts (A307), 3
 - Rivets, 2, 9
 - Slip resistance, 28
 - Tension-control bolts, 18
 - Turn-of-nut installation, 17
 - Washer requirements, 16, 45
- Prying forces, 39
- Reinstallation of high-strength bolts, 47
- Reuse of high-strength bolts, 47
- Research Council on Structural Connections (RCSC)
 - History, 1
 - Specifications, 3
- Resistance factor, 7
- Rivets
 - Clamping force, 2
 - Combined shear and tension, 10
 - Fatigue strength, 41
 - Installation, 2
 - Mechanical properties, 1
 - Shear strength, 9
 - Tensile strength, 9
- Serviceability limit state, 7
- Shear (in fasteners)
 - Combined shear and tension, bolts, 25
 - Combined shear and tension, rivets, 10
 - Effect of pretension, 15
 - Shear strength of bolts, 24, 30
 - Shear strength of rivets, 9
- Shear lag, 33
- Slip in joints, 27
- Slip-critical joints, 20, 28
- Slip coefficient, 29
- Slip resistance, 29
- Slotted holes, 45
- Snug-tightened bolts, 13, 19
- Surface coatings, 48
- Tensile stress area, 2, 24
- Tension-control bolts, 18
- Tension strength of bolts, 23, 37
- Tension strength of rivets, 9
- Tension-type connections, 5, 37
- Torque vs. tension relationship, 17
- Truss-type connections, 4
- Turn-of-nut method of installation, 14
- Washers
 - Load-indicating washers, 19
 - Standard washers, 16, 45